

ISSN 1846-9795

Sveučilište u Rijeci  
TEHNIČKI FAKULTET



University of Rijeka  
FACULTY OF ENGINEERING



**GODIŠNJAK  
TEHNIČKOG  
FAKULTETA**  
Sveučilišta u Rijeci

**ANNUAL REPORT  
OF THE FACULTY  
OF ENGINEERING**  
University of Rijeka

**GODIŠNJAK  
TEHNIČKOG FAKULTETA**  
**ANNUAL REPORT  
OF THE FACULTY OF ENGINEERING**

Sveučilište u Rijeci  
University of Rijeka

**2019./2020.**  
**2019/2020**



*Sveučilište u Rijeci  
Tehnički fakultet*

*University of Rijeka  
Faculty of Engineering*

**GODIŠNJAK TEHNIČKOG FAKULTETA SVEUČILIŠTA U RIJECI 2019./2020.**  
ANNUAL REPORT OF THE FACULTY OF ENGINEERING UNIVERSITY OF  
RIJEKA 2019/2020

UDK / UDC: 378.662 (497.5 Rijeka)(058)

**God.** / Vol. 13  
**Str.** / P. 1-288 Rijeka, 2020.

**IZDAVAČ** | PUBLISHER:  
Sveučilište u Rijeci, Tehnički fakultet  
/ University of Rijeka, Faculty of Engineering

**GLAVNI UREDNIK** | EDITOR-IN-CHIEF:  
doc. dr. sc. / Assist. Prof. D. Sc. Sanjin Krščanski

**ZAMJENICA UREDNIKA** | DEPUTY EDITOR:  
doc. dr. sc. / Assist. Prof. D. Sc. Loredana Simčić

**UREDNIČKI ODBOR** | EDITORIAL BOARD:  
prof. dr. sc. / Prof. D. Sc. Duško Pavletić;  
prof. dr. sc. / Prof. D. Sc. Anica Trp;  
prof. dr. sc. / Prof. D. Sc. Marina Franulović;  
izv. prof. dr. sc. / Assoc. Prof. D. Sc. Ivan Štajduhar;  
doc. dr. sc. / Assist. Prof. D. Sc. Sanjin Krščanski;  
doc. dr. sc. / Assist. Prof. D. Sc. Loredana Simčić;  
Diego Sušan; Damjan Banić; Luka Grbčić

**LEKTURA** | PROOFREADING:  
Marta Lončarević, prof., dipl. knjižničarka / Prof., Grad. Librarian  
(hrvatski / Croatian);  
mr. sc. / M. Sc. Elisa Velčić Janjetić, v. pred / Sen. Lect (engleski / English),  
Anita Badurina, pred. / Lect (engleski / English)

**PRIJELOM** | LAYOUT DESIGN:  
Lea Grgurić

**ADRESA UREDNIŠTVA** | EDITORIAL BOARD ADDRESS:  
Godišnjak Tehničkog fakulteta Sveučilišta u Rijeci  
51000 Rijeka, Vukovarska 58, Hrvatska / Croatia

Tel.: +385 (0)51 / 651 - 444 Fax: +385 (0)51 / 651 - 416  
dekanat@riteh.hr | www.riteh.uniri.hr

**UČESTALOST IZLAŽENJA** | PUBLISHED:  
Jednom godišnje / Annually

**TISAK** | PRINTED BY:  
TEHNIČAR-COPYSERVIS d.o.o.

**NAKLADA** | EDITION:  
300 primjeraka / pcs.

<b>PREDGOVOR DEKANA</b>	
DEAN'S PREFACE .....	7
<b>60 GODINA FAKULTETA</b>	
60 YEARS OF THE FACULTY .....	14
<b>1 OPĆE INFORMACIJE</b>	
GENERAL INFORMATION .....	33
<b>2 FAKULTET U AKADEMSKOJ GODINI 2019./2020.</b>	
FACULTY IN THE ACADEMIC YEAR 2019/2020 .....	42
2.1 opće informacije	
general information .....	42
2.2 studenti nagrađeni u ak. godini 2019./2020.	
awarded students in the 2019/2020 academic year .....	46
2.3 časopis "engineering review"	
the journal engineering review .....	48
2.4 alumni tfr.....	50
2.5 doktorske disertacije obranjene u akademskoj godini 2019./2020	
doctoral dissertations defended in academic year 2019/2020.....	52
2.6 aktivnosti, zbivanja i konferencije	
activities, events and conferences .....	64
2.6.1 EU projekti	
EU projects .....	64
2.6.2 HRZZ projekti	
HRZZ projects.....	78
2.6.3 job.fair i dan otvorenih laboratorija 2019	
job.fair and open lab day 2019.....	86
2.6.4 energetske dane 2019	
energy days 2019 .....	90
2.6.5 my first conference 2020 .....	92
2.6.6 8. savjetovanje o morskoj tehnologiji	
8 <sup>th</sup> international conference on marine technology .....	94
2.6.7 studentski diplomski radovi	
student graduate theses .....	98
<b>3 STUDIJSKI PROGRAMI NA FAKULTETU</b>	
STUDY PROGRAMS AT THE FACULTY .....	122
<b>4 DEKANAT</b>	
DEAN'S OFFICE .....	142
<b>5 ZAVODI</b>	
DEPARTMENTS.....	146
5.1 zavod za automatiku i elektroniku	
department of automation and electronics .....	147
5.2 zavod za brodogradnju i inženjerstvo morske tehnologije	
department of naval architecture and ocean engineering.....	157
5.3 zavod za elektroenergetiku	
department of electric power systems .....	167

5.4 zavod za industrijsko inženjerstvo i management   department of industrial engineering and management.....	173
5.5 zavod za konstruiranje u strojarstvu   department of mechanical engineering design .....	181
5.6 zavod za matematiku, fiziku, strane jezike i kineziologiju   department of mathematics, physics, foreign languages and kinesiology ..	191
5.7 zavod za materijale   department of materials science and engineering .....	197
5.8 zavod za mehaniku fluida i računarsko inženjerstvo   department of fluid mechanics and computational engineering.....	203
5.9 zavod za računarstvo   department of computer engineering .....	209
5.10 zavod za tehničku mehaniku   department of engineering mechanics.....	221
5.11 zavod za termodinamiku i energetiku   department of thermodynamics and energy engineering.....	229
<b>6 STRUČNE SLUŽBE</b>   PROFESSIONAL AND ADMINISTRATIVE STAFF .....	<b>241</b>
6.1 knjižnica   library .....	242
6.2 računalni centar   computer center .....	244
6.3 financijska služba   accounting division.....	246
6.4 služba nabave i komercijale   procurement and commerciale office.....	248
6.5 služba općih i kadrovskih poslova   general and personnel office.....	249
6.6 služba studentske evidencije   student's registrar and affairs office .....	252
6.7 tehnička služba   technical and maintenance services.....	253
<b>7 STUDENTSKE AKTIVNOSTI</b>   STUDENT ACTIVITIES .....	<b>256</b>
7.1 studentski zbor tehničkog fakulteta   student council at the faculty of engineering.....	257
7.2 IEEE studentski ogranak sveučilišta u rijeci   ieee university of rijeka student branch.....	260
7.3 IAESTE.....	264
7.4 natjecanje timova studenata informatičara hrvatskih sveučilišta 2019   croatian collegiate programming contest 2019 .....	266
7.5 riteh racing team.....	268
7.6 riteh waterbike team & adria hydrofoil team.....	271
7.7 riteh drone team .....	274
7.8 riteh web team.....	276
7.9 projekt here   the "here" project.....	279
7.10 21. mornarska regata   21 <sup>st</sup> rowing regatta .....	281
7.11 akademski sport - uspjesi sportaša   academic sport - achievements of athletes.....	283

## predgovor dekana dean's preface



Poštovani studenti, djelatnici, suradnici i prijatelji Tehničkog fakulteta,

Godišnjak koji imate u rukama daje pregled aktivnosti i postignuća naših studenata, djelatnika i suradnika ostvarenih tijekom akademske godine 2019./2020. S posebnim ponosom ističem da je ova akademska godina ujedno i šezdeseta godina postojanja i djelovanja Tehničkog fakulteta Sveučilišta u Rijeci. U svojih šezdeset godina postojanja Fakultet se pozicionirao kao organizirana i prepoznatljiva sastavnica Sveučilišta u Rijeci te kao jedna od vodećih institucija u Hrvatskoj koja odgaja i obrazuje stručnjake u poljima strojarstva, brodogradnje, elektrotehnike i računarstva. Rezultat je to ustrajnog rada generacija studenata, djelatnika i suradnika Fakulteta, koji su svojim doprinosom gradili ugled i prepoznatljivost Fakulteta. Na tako postavljenim temeljima Fakultet je i u ovoj, jubilarnoj, akademskoj godini nastavio jačati svoje kapacitete i doprinositi zajednici u kojoj djeluje.

Uz neprekinuto ostvarivanje svoje obrazovne uloge, stvarajući visokoobrazovane stručnjake u području Tehničkih znanosti, značajna je znanstvena i stručna djelatnost Fakulteta. U ovoj je akademskoj godini, pored nastavka rada na prethodno odobrenim znanstvenoistraživačkim projektima, aktivnost naših djelatnika rezultirala brojnim prijavama novih znanstvenih projekata, pa je tako, primjerice, Fakultet uključen u prijave devet projekata Europskog fonda za regionalni razvoj, usmjerenih povećanju razvoja novih proizvoda i usluga koji proizlaze iz aktivnosti istraživanja i razvoja (IRI2) te osam istraživačkih i bilateralnih projekata Hrvatske zaklade za znanost. Potom, prijavljeni su projekti iz Erasmus+, Obzor 2020, COST i CEF programa i projekti vezani uz novonastalu epidemiološku situaciju uslijed pojave korona virusa. Dodatno, naši znanstvenici se kao suradnici i istraživači uključuju u brojne HRZZ projekte na drugim institucijama.

Dear students, staff, associates and friends of the Faculty of Engineering,

the Annual Report which you have in your hands gives an overview of the activities and achievements of our students, staff and associates during the 2019/2020 academic year. I am especially proud to point out that this academic year is also the sixtieth year of the existence of the Faculty of Engineering of the University of Rijeka. In its sixty years of existence, the Faculty has established itself as a highly organised and recognisable constituent institution of the University of Rijeka and as one of the leading institutions in Croatia, educating professionals in the fields of Mechanical Engineering, Naval Architecture, Electrical Engineering and Computer Engineering. This is the result of the persistent work of generations of students, staff and associates of the Faculty, who have been building the reputation and visibility of the Faculty. On this foundation, the Faculty has continued to strengthen its capacities and contribute to the community in which it operates in this jubilee academic year.

In addition to the continuous realisation of its educational role, creating highly educated professionals in the field of Engineering Sciences, the scientific and professional activity of the Faculty is significant. In this academic year, in addition to continuing the work on previously approved scientific research projects, the activity of our employees has resulted in numerous applications for new scientific projects, so, for example, the Faculty has been included in the applications for nine projects of the European Regional Development Fund, focusing on an increase in the development of new products and services which arise from research and development activities (IRI2) and eight research and bilateral projects of the Croatian Science Foundation. Furthermore, we applied for projects

Započelo je financiranje dodatnih dvaju projekata Hrvatske zaklade za znanost kojih su voditelji prof. dr. sc. Marko Čanađija i prof. dr. sc. Domagoj Lanc, prihvaćen je za financiranje projektni prijedlog istraživačke skupine pod vodstvom prof. dr. sc. Zlatana Cara u sklopu poziva CEI Extraordinary Call for Proposals 2020 i projektni prijedlog istraživačke skupine pod vodstvom prof. dr. sc. Lade Kranjčevića, EU projekt iz Operativnog programa Konkurentnost i kohezija 2014-2020. Fakultet je uključen i u dva nova projekta financirana okvirom COST European Cooperation in Science and Technology te je sunositelj znanstvenoistraživačkog projekta u sklopu zajedničke hrvatsko-slovenske suradnje pod vodstvom doc. dr. sc. Jonatana Lerge.

Slijedom prijava na natječaj „Projekt razvoja karijera mladih istraživača – izobrazba novih doktora znanosti“ prihvaćeno je financiranje četiri doktoranda i to pod mentorstvima prof. dr. sc. Marka Čanađije, prof. dr. sc. Lada Kranjčevića, prof. dr. sc. Jasne Prpić-Oršić i doc. dr. sc. Gorana Mauše.

Ova zapažena znanstvena aktivnost dijelom je rezultat i kontinuiranog, višegodišnjeg, sustavnog ulaganja Fakulteta u unaprjeđenje uvjeta rada u nastavnim i laboratorijskim prostorima. U akademskoj godini 2019./2020. uloženo je više od tri milijuna kuna u nabavku nove laboratorijske opreme, razvoj računalne infrastrukture i održavanje prostora Fakulteta. Posebno bih istaknuo da su dva naša informatička kabineta (I1 i I3), namijenjena radu studenata, u potpunosti opremljena novom računalnom opremom. Propusnost mrežne infrastrukture Fakulteta je na komunikacijskim čvorovima nadograđena s 1 Gbps na 10 Gbps, a nabavljena su i dva nova poslužiteljska računala namijenjena isključivo kao potpora održavanju nastave na daljinu.

Pored spomenutih, prošla je akademska godina bila obilježena i brojnim drugim događanjima. Agencija za znanosti i visoko obrazovanje uspješno je provela reakreditaciju doktorskog studija računarstva čime je dobivena dopusnica za provedbu studija. Tako je još jednom potvrđena visoka razina kvalitete rada Fakulteta i promišljanja i predlaganja suvremenih, znanstveno utemeljenih i relevantnih studijskih programa na svim razinama visokog obrazovanja, uključujući i ovu najvišu, doktorsku razinu. Dobivanjem ove dopusnice Fakultet ima akreditirana tri studijska programa na doktorskoj razini koji pokrivaju sva polja u kojima Tehnički fakultet obrazuje kadrove.

from Erasmus +, Horizon 2020, COST and CEF programs and projects related to the emerging epidemiological situation due to the appearance of the coronavirus. In addition, our scientists as collaborators and researchers cooperate with other institutions in numerous projects of the Croatian Science Foundation.

The financing of two additional projects of the Croatian Science Foundation, led by Prof. D. Sc. Marko Čanađija and Prof. D. Sc. Domagoj Lanc started; the project proposal of the research group led by Prof. D. Sc. Zlatan Car as part of the CEI Extraordinary Call for Proposals 2020 and the project proposal of the research group led by Prof. D. Sc. Lado Kranjčević, an EU project from the Operational Program Competitiveness and Cohesion 2014-2020 were accepted. The Faculty is also involved in two new projects funded by the COST European Cooperation in Science and Technology and is a co-holder of a scientific research project within the joint Croatian-Slovenian cooperation led by Assist. Prof. D. Sc. Jonathan Lerga.

Following the applications for the project "Career Development Project for Young Researchers - Training of New Doctors of Science", the financing of four PhD students was accepted under the mentorship of Prof. D. Sc. Marko Čanađija, Prof. D. Sc. Lado Kranjčević, Prof. D. Sc. Jasna Prpić-Oršić and Assist. Prof. D. Sc. Goran Mauša.

This notable scientific activity is partly the result of continuous, several years, systematic investment of the Faculty in improving the working conditions in teaching and laboratory premises. In the 2019/2020 academic year, more than three million kunas were invested in purchasing new laboratory equipment, developing computer infrastructure and maintenance of the Faculty premises. I would especially like to point out that two of our IT cabinets (I1 and I3), intended for student work, have been fully equipped with new computer equipment. The bandwidth of the Faculty's network infrastructure has been upgraded from 1 GBps to 10 GBps at the communication nodes, and two new server computers, intended exclusively to support distance teaching, have been acquired.

In addition to the above, the previous academic year was marked by numerous events. The Agency of Science and Higher Education successfully re-accredited the doctoral study of Computer Engineering, thus obtaining a permit to conduct the study. Thus, the high level of quality of the Faculty's work and the reflection and proposal of modern, scientifically based and

relevant study programs at all levels of higher education, including this highest, doctoral level, was once again confirmed. By obtaining this permit, the Faculty has accredited three study programmes at the doctoral level that cover all fields in which the Faculty of Engineering educates its staff.

The study programmes of postgraduate university (doctoral) studies in the field of Engineering Sciences, the fields of Mechanical Engineering, Naval Architecture, Fundamental Engineering Sciences and Interdisciplinary Engineering Sciences and in the field of Electrical Engineering have been modernised.

The recertification of the quality management system according to the ISO 9001 standard was successfully carried out by an independent certification institution, which reconfirmed the high level of orderliness of our support processes.

“The VIII. Conference on marine technology in memoriam to the academician Zlatko Winkler” was held at the Faculty. The conference was attended by more than 100 participants. In addition to adhering to special epidemiological measures, the fourth annual conference of doctoral students called My First Conference was successfully held. The Faculty hosted and co-organised the third Croatian exhibition of innovations in mechanical engineering, naval architecture and electrical engineering. Several lectures by distinguished guest lecturers were held at the Faculty.

Na svečanosti u Hrvatskome saboru, prof. emer. dr. sc. Josipu Brniću, dodijeljena je državna nagrada za životno djelo za područje tehničkih znanosti. Posebne zahvalnice Sveučilišta u Rijeci dobili su prof. emer. dr. sc. Josip Brnić, prof. emer. dr. sc. Elso Kuljanić, prof. dr. sc. Miroslav Vrankić, doc. dr. sc. Jonatan Lerga te Riteh Racing Team.

Došlo je i do promjene u uredništvu našeg znanstvenog časopisa Engineering Review. Nakon dugogodišnjeg uspješnog uređivanja časopisa, na osobni zahtjev, dužnosti glavnog urednika razriješen je prof. emer. dr. sc. Josip Brnić. Ovim putem mu se zahvaljujem na uloženom iznimnom trudu u podizanju ugleda našeg časopisa i na postignutom uspjehu. Novim glavnim urednicima imenovani su prof. dr. sc. Marina Franulović i prof. dr. sc. Domagoj Lanc. Želim im puno uspjeha na ovoj novoj dužnosti.

Pod vodstvom izv. prof. dr. sc. Saše Sladića, Tehnički fakultet je sa svojim ženskim i muškim veslačkim ekipama uspješno nastupio na 21. međunarodnoj regati u mornarskom veslanju u slovenskom Portorožu.

Nastavljeno je sufinanciranje i podrška studentskim timovima Fakulteta kao i podrška studentskim sportskim aktivnostima.

Naši studenti dobitnici su zapaženih nagrada i priznanja, primjerice kolegica Anja Mirić, studentica 2. godine diplomskog sveučilišnog studija Strojarstvo, dobitnica je Rektorove nagrade za izvrsnost.

Under the leadership of Assoc. Prof. D. Sc. Saša Sladić, the Faculty of Engineering with its female

relevant study programs at all levels of higher education, including this highest, doctoral level, was once again confirmed. By obtaining this permit, the Faculty has accredited three study programmes at the doctoral level that cover all fields in which the Faculty of Engineering educates its staff.

The recertification of the quality management system according to the ISO 9001 standard was successfully carried out by an independent certification institution, which reconfirmed the high level of orderliness of our support processes.

“The VIII. Conference on marine technology in memoriam to the academician Zlatko Winkler” was held at the Faculty. The conference was attended by more than 100 participants. In addition to adhering to special epidemiological measures, the fourth annual conference of doctoral students called My First Conference was successfully held. The Faculty hosted and co-organised the third Croatian exhibition of innovations in mechanical engineering, naval architecture and electrical engineering. Several lectures by distinguished guest lecturers were held at the Faculty.

At the ceremony in the Croatian Parliament, Prof. Emeritus D. Sc. Josip Brnić was awarded with the national lifetime achievement award in the field of engineering sciences. Letters of thanks of the University of Rijeka were given to Prof. Emeritus D. Sc. Josip Brnić, Prof. Emeritus D. Sc. Elso Kuljanić, Prof. D. Sc. Miroslav Vrankić, Assist. Prof. D. Sc. Jonathan Lerga and the Riteh Racing Team.

There has also been a change in the editorial board of our scientific journal Engineering Review. After many years of successful editing of the journal, at his personal request, Prof. Emeritus D. Sc. Josip Brnić was relieved of his duty. I would like to thank him for his exceptional efforts in raising the reputation of our journal and for the success he achieved. The new editors-in-chief are Prof. D. Sc. Marina Franulović and Prof. D. Sc. Domagoj Lanc. I wish them success in this new position.

Under the leadership of Assoc. Prof. D. Sc. Saša Sladić, the Faculty of Engineering with its female

U prostorima Fakulteta po treći put smo organizirali JobFair, sajam poslova koji očekuju naše buduće inženjere. Job Fair organiziran je istoga dana kada i Dan otvorenih laboratorija Tehničkog fakulteta na kojem se učenicima srednjih škola omogućilo aktivno sudjelovanje u eksperimentalnoj nastavi i upoznavanje sa životom i radom naših studenata na Fakultetu. I ovaj put interes učenika je bio velik. Organizirane su i besplatne pripreme za ispit iz više razine matematike na državnoj maturi za sve maturante kojima su studiji Tehničkog fakulteta prvi ili drugi izbor.

Ovaj uvodnik i osvrt na proteklu akademsku godinu nemoguće je zaključiti bez spomena izvanrednih okolnosti u kojima smo se nenadano i naglo našli. Početkom ljetnog semestra, u ožujku 2020. g., ostali smo zatečeni vijestima o pojavi epidemije, a potom i pandemije, uzrokovane novim korona virusom. Situacija je to u kojoj se do sada naš Fakultet, ali niti jedna druga visokoškolska ustanova u RH, nije nalazila i za koju nema prethodnog iskustva niti predviđenih i potvrđenih procedura postupanja. Ta je situacija zahtijevala brzu reakciju i promjenu ustaljenih praksi i prilagodbu na novonastale okolnosti. U vrlo kratkom roku, gotovo trenutno, prešli smo na održavanje svih nastavnih aktivnosti u virtualnom okruženju, na daljinu, bez prisutnosti studenata i nastavnika u prostorijama Fakulteta. Sve aktivnosti su prilagođene novonastaloj situaciji. Tako su, primjerice, završni i diplomski radovi, kao i dvije doktorske disertacije, uspješno obranjeni u online okruženju. Smatram da smo na ovaj izazov bez presedana u povijesti Fakulteta odgovorili zrelo, promišljeno i učinkovito, osiguravajući da se sve naše osnovne aktivnosti odvijaju bez zastoja, na vrijeme i u predviđenom obimu, a sve kako bi se, prvenstveno studentima, omogućio neometani nastavak studiranja.

Nažalost, novonastala situacija je ipak uvjetovala zaustavljanje brojnih naših uobičajenih aktivnosti, značajno je smanjena mobilnost studenata i nastavnika, otkazane su ili u virtualnom okruženju održane konferencije i znanstveni skupovi, nisu održana studentska sportska natjecanja (primjerice STEM Games) i dr.

Nadam se i iskreno vjerujem da će se ova situacija u skorije vrijeme razriješiti i da ćemo svi zajedno moći neometano nastaviti doprinositi razvoju našeg Fakulteta.

Ove nas je godine, nažalost, prerano napustio naš dragi kolega i prijatelj Goran Bakotić, voditelj Tehničke službe. Velika mu hvala na njegovom uvijek pozitivnom stavu i zapaženom doprinosu našem Fakultetu.

and male rowing teams successfully participated in the 21st International Sailor Rowing Regatta in Portorož, Slovenia.

Co-financing and support to student teams of the Faculty as well as support to student sports activities has continued.

Our students are winners of notable awards and recognitions, for example, colleague Anja Mirić, a 2nd year student of the graduate university study of Mechanical Engineering, is the winner of the Rector's Award for Excellence.

For the third time, we organised the JobFair, a job fair that awaits our future engineers. It was organised on the same day as the Open Laboratories Day of the Faculty of Engineering, where high school students were able to participate actively in experimental teaching and were able to get acquainted with the life and work of our students at the Faculty. And also this time the interest of the students was great. Free preparations for the exam in higher levels of mathematics at the national school-leaving examinations were organised for all the graduates who opted for studies at the Faculty of Engineering as their first or second choice.

This Annual Report and reflection on the past academic year is impossible to conclude without mentioning the extraordinary circumstances in which we suddenly and abruptly found ourselves. At the beginning of the summer semester, in March 2020, we were surprised by the news of the outbreak of an epidemic, and then a pandemic, caused by the new coronavirus. This is a situation in which neither our Faculty nor any other higher educational institution in the Republic of Croatia have ever experienced and for which there is no previous experience or planned and confirmed procedures. This situation required a quick reaction and a change in the established practices and adaptation to the new circumstances. In a very short time, almost immediately, we moved on to holding all teaching activities in a virtual environment, remotely, without the presence of students and teachers in the premises of the Faculty. All activities have been adapted to the new situation. Thus, for example, final and graduate theses, as well as two doctoral dissertations, were successfully defended in an online environment. I believe that we responded to this unprecedented challenge in the history of the Faculty maturely, thoughtfully and efficiently, ensuring that all our basic activities take place without delay, on time and on schedule, all in order to enable primarily the students to continue their studies.

Na kraju jedne akademske godine očekivano je pogled usmjeriti i prema novoj akademskoj godini i vremenu koje je pred nama. Uz sve naše već uobičajene aktivnosti, predstoji nam donošenje nove Strategije razvoja Fakulteta, revidiranje i unaprjeđenje postojećih preddiplomskih i diplomskih sveučilišnih studijskih programa, snažnije povezivanje sa stručnjacima iz gospodarstva i javnog sektora, definiranje osnovnih smjernica internacionalizacije Fakulteta, jačanje prisutnosti Fakulteta u javnosti, revidiranje i osvježavanje mrežnih stranica Fakulteta i još mnogo drugih aktivnosti...

Na kraju, koristim ovu priliku da svim studentima, djelatnicima i suradnicima Tehničkog fakulteta čestitam šezdesetu obljetnicu Fakulteta te im zahvalim na njihovom doprinosu razvoju naše ustanove. Posebno zahvaljujem svima koje u ovom kratkom uvodniku nisam spomenuo, a svojim doprinosom i zapaženim rezultatima to svakako zaslužuju.

Na uloženom trudu i naporu u prikupljanju, pripremi i obradi građe Godišnjaka veliku zahvalnost izražavam radnoj skupini koju je, kao glavni urednik, predvodio doc. dr. sc. Sanjin Krščanski, a uz njega su je činili doc. dr. sc. Loredana Simčić i asistenti Damjan Banić, Diego Sušanji i Luka Grbčić.

Želim vam ugodno čitanje ovogodišnjeg Godišnjaka Tehničkog fakulteta.

U Rijeci 30. rujna 2020.

Dean  
Prof. dr. sc. Duško Pavletić

Unfortunately, the new situation has caused the cessation of many of our usual activities, significantly reduced student and teacher mobility, conferences and scientific symposia were cancelled or held in a virtual environment and no student sports competitions (e.g. STEM Games) or any others took place.

I hope and sincerely believe that this situation will be resolved soon and that we will all be able to continue to contribute to the development of our Faculty.

This year, unfortunately, our dear colleague and friend Goran Bakotić, the head of the Technical and Maintenance Service, left us too early. Many thanks to him for his always positive attitude and notable contribution to our Faculty.

At the end of one academic year, it is expected to take a look at the new academic year and the time ahead of us. In addition to all our usual activities, we are about to adopt a new Strategy for the development of the Faculty, revise and improve the existing undergraduate and graduate university study programs, build stronger connections with experts from the economy and public sector, define basic guidelines for the internationalisation of the Faculty, strengthen the presence of the Faculty in public, revise and refresh the Faculty's website and many other activities...

Finally, I take this opportunity to congratulate all students, staff and associates of the Faculty of Engineering on the sixtieth anniversary of the Faculty and thank them for their contribution to the development of our institution. Special thanks to everyone I haven't mentioned in this Annual Report, and with their contribution and notable results they certainly deserve it.

For the effort put in collecting, preparing and organising the material of the Annual Report, I would like to express my gratitude to the working group led by the editor-in-chief Assist. Prof. D. Sc. Sanjin Krščanski, who was accompanied by Assist. D. Sc. Loredana Simčić and assistants Damjan Banić, Diego Sušanji and Luka Grbčić.

I wish you a pleasant reading of this year's Annual Report of the Faculty of Engineering.

In Rijeka, 30th September 2020

Dean  
Prof. D. Sc. Duško Pavletić



# 60 godina fakulteta years of faculty

Tradicija visokoga školstva u gradu Rijeci počinje još 1627. godine. Sustavno školovanje tehničkih kadrova na ovome području počinje 1854. godine, odlukom o premještanju Carsko-kraljevske Mornaričke akademije iz Trsta u Rijeku. Tom je odlukom uveden redoviti četverogodišnji studij sa sadržajima izobrazbe iz područja gradnje željeznih brodova i parnih strojeva za potrebe tadašnje austrijske vojske, koji se održavao sve do razdoblja nakon 1. svjetskog rata. Temelji Tehničkog fakulteta su i tehnička postignuća u našem gradu i okolici poput izuma torpeda 1866. godine, snimke udarnog tlačnog vala oko pu-

The tradition of higher education in the city of Rijeka dates back to 1627. The systematic training of the technical personnel in this area began with the decision to move the Austrian Imperial-Royal Naval Academy from Trieste to Rijeka in 1854. This decision introduced a regular four-year study with the contents of training in the field of construction of iron ships and steam engines for the needs of the Austrian army, which lasted until the period after World War I. The foundations of the Faculty of Engineering are also technical achievements in our city and its surroundings, such as the invention of the torpedo in 1866, the



Die k. u. k. Marine-Akademie in Fiume.

ščanog metka u letu 1886. godine, koje je prvi u svijetu izradio prof. dr. Peter Salcher, rođenja i prvih znanstvenih postignuća svjetski poznatog seizmologa i meteorologa Andrije Mohorovičića te razvoja nekih od ključnih elementa u brodograđevnoj i strojarскоj industriji, kao i u energetici. Tako je 1866. godine u Rijeci započelo akademsko tehničko obrazovanje i znanstvena djelatnost u području specifičnih stručnih i općih tehničkih sadržaja.

Razvoj industrije u riječkoj regiji

Na području sjevernog Jadrana, od najranije povijesti, pratimo razvoj brodogradnje, pomorstva, trgovine, prerade i razmjene roba. Gradnja čuvenih drvenih brodova bila je razvijena na obalama Kvarnera, otocima Lošinj, Cresu i Krku te

snapshots of shock pressure waves around the flying bullet in 1886, which were taken for the first time in the world by Prof Dr Peter Salcher. Furthermore, the birth and the first scientific achievements of the world-famous seismologist and meteorologist Andrija Mohorovičić as well as the development of some of the key elements in naval architecture, mechanical engineering industries and power engineering were important for the development of the Faculty of Engineering. Thus, in 1866, academic engineering education and scientific activity in the field of specific professional and general engineering contents began in Rijeka.

Industry development in the region of Rijeka

In the area of the northern Adriatic, from the ear-

u Istri. Zapaženija brodogradnja započela je najprije u Kraljevici 1729. godine kada car Karlo VI. određuje izgradnju arsenala i brodogradilišta za gradnju ratnih brodova. Tako bilježimo gradnju bark-klipera Karlovac u brodogradilištu Kraljevica 1867. godine. Prvi brod željezne konstrukcije izgrađen je 1902. godine.

Brodogradilište u Puli osnovano je 1856. godine kao arsenal austrijske ratne mornarice. Porinuće prve gradnje, ratnog broda Kaiser, bilo je 1858. godine. Kasnije su izgrađeni mnogi ratni brodovi i podmornice, a treba spomenuti da je 1866. godine u Puli izgrađen prvi plovni dok u Europi.

1862. godine na području Rijeke djelovalo je 12 manjih brodogradilišta. U tadašnjem Howaldtsovu brodogradilištu u Rijeci, 1894. godine započela je gradnja velikih željeznih brodova. Ovo brodogradilište od 1905. godine nastavlja raditi kao Schiffbau und Maschinenfabriks A. G. Danubius, a nakon 1911. godine pod imenom Ganz-Danubius. Tu je 1914. godine porinut jedan od najvećih europskih ratnih brodova Szent Istvan. Brodogradilišta u Puli, Rijeci i Kraljevici bilježe izgradnju mnogih brodova austrougarske ratne flote koji su u to vrijeme, po brodograđevnim rješenjima i svojoj opremi, predstavljali najnovija dostignuća u svim područjima tehnike.

Brodogradilišta su tada proživljavala brojne promjene, Arsenal u Puli prerastao je u Uljanik, a brodogradilište Ganz-Danubius u 3. MAJ. Broj brodogradilišta u Rijeci povećan je osnivanjem remontnog brodogradilišta Viktor Lenac u Rijeci.

liest history we have been following the development of naval architecture, maritime affairs, trade, processing and exchange of goods. The construction of famous wooden ships was developed on the shores of the Kvarner bay, the islands of Lošinj, Cres and Krk, and in Istria. Notable shipbuilding began first in Kraljevica in 1729 when Emperor Charles VI. determined the establishment of an arsenal and a shipyard for the construction of warships. Thus, we record the construction of the clipper ship Karlovac in the Kraljevica shipyard in 1867. The first iron ship was built in 1902.

The shipyard in Pula was founded in 1856 as an arsenal of the Austrian Navy. The first warship named Kaiser was launched in 1858. Later, many warships and submarines were built, and it should be mentioned that in 1866 the first navigable dock in Europe was built in Pula.

In 1862, there were 12 smaller shipyards in the area of Rijeka. In 1894, the construction of large iron ships began at the former Howaldts' Shipyard in Rijeka. This shipyard continued to operate since 1905 as Schiffbau- und Maschinenfabrik A.G. Danubius, and after 1911 under the name Ganz – Danubius. In 1914, one of the largest European warships "Szent Istvan" was launched there. The shipyards in Pula, Rijeka and Kraljevica were famous for the construction of many ships of the Austro-Hungarian navy, which at that time represented the latest achievements in all fields of technology in terms

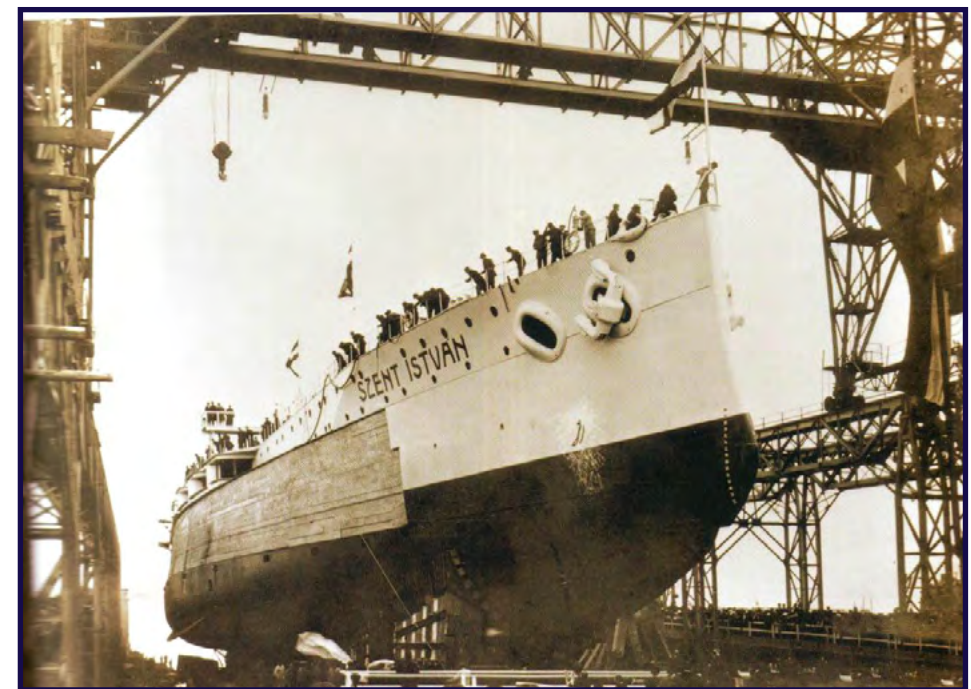



Godine 1854. u Rijeci počinje djelovati prva moderna strojograđevna industrija Fonderia Metalli kao ljevaonica i radionica. Dolaskom engleskog strojarškog inženjera Roberta Whiteheada, u Rijeci započinje proizvodnja parnih strojeva, a kasnije tvrtka mijenja naziv u Stabilimento tecnico Fiumano.

U toj tvornici izrađen je 1866. godine i prvi torped. Idejni začetnik torpeda bio je umirovljeni kapetan fregate austrougarske mornarice Giovanni Luppis, rođeni Riječanin. Zamislio je plovilo vođeno s kopna (salvacoste), s pogonom na jedra, natovareno eksplozivom i s upaljačem na pramcu koji bi izazvao eksploziju pri sudaru s neprijateljskim brodom. Whitehead je usavršio Luppisovu napravu i proizveo prvi torped u svijetu.

U Rijeci je 1764. godine osnovana tvornica konopa za brodove, najstarije industrijsko postrojenje. Jedinствен pogon bila je riječka tvornica kemijskih proizvoda, osnovana 1852. godine. U Rijeci su sredinom 19. stoljeća djelovale i tvornica sapuna, tvornica svijeća i četiri kožare. Tvornica papira, popularna Hartera, utemeljena je u Rijeci 1821. godine, zahvaljujući poduzetničkom duhu Andrije Ljudevita Adamića. U tvornici je 1833. godine instaliran pogonski parni stroj, prvi u ovome dijelu Europe. Prva rafinerija nafte u Hrvatskoj, kao jedna od prvih u Europi, osnovana je 1882. godine te je započela s radom 1883. godine u Rijeci. Izgradnju Rafinerije vodio je Milutin Barač koji je svojim rješenjima uvelike unaprijedio procese prerade sirove nafte i derivata. Ulica u kojoj su se donedavno nalazile Pogonska i Upravna zgrada Rafinerije nafte i danas nosi njegovo ime.

of shipbuilding solutions and their equipment.

The shipyards were undergoing numerous changes at that time, the Arsenal in Pula grew into Uljanik, and the Ganz-Danubius shipyard into 3. MAJ. The number of shipyards in Rijeka increased by the establishment of the overhaul shipyard "Viktor Lenac" in Rijeka.



In 1854, the first modern engineering industry, Fonderia Metalli, began operating in Rijeka as a foundry and workshop. With the arrival of Robert Whitehead, an English mechanical engineer, the production of steam engines began in Rijeka, and later the com-

pany changed its name to Stabilimento tecnico Fiumano.

The first torpedo was made in that factory in 1866. The originator of the torpedo was the retired captain of the Austro-Hungarian Navy frigate Giovanni Luppis, born in Rijeka. He imagined a vessel guided from the mainland (salvacoste), propelled by sails, loaded with explosives and with a lighter on the bow that would cause an explosion in case of collision with an enemy ship. Whitehead perfected Luppis' device and produced the world's first torpedo.

In 1764, a ship rope factory was established in Rijeka, the oldest industrial plant. In 1852, a unique plant was the Rijeka factory of chemical products. In the middle of the 19th century, a soap factory, a candle factory and four tanneries also operated in Rijeka. The paper factory, the popular Hartera, was founded in Rijeka in 1821 thanks to the entrepreneurial spirit of Andrija Ljudevit Adamić. In 1833, a steam engine was installed in the factory, the first in this part

Davne 1852. godine u Rijeci je s radom započela prva plinara. Tada je Rijeka bila osvijetljena s 226 plinskih svjetiljki lepezasta plamena. Uпотреba plina brzo se širila pa se već 1856. godine uvodi plinska rasvjeta i u Gradsko kazalište. Potkraj 19. stoljeća izgrađene su prve elektrane, izuzetno značajne kao izvor energije za pogon strojeva u radionici, za javnu rasvjetu gradskih trgova i prometnica, rasvjetu pojedinih javnih objekata te rasvjetu u kućanstvima. U Rijeci je 1892. godine izgrađena javna elektrana s tri generatora izmjenične jednofazne struje, a 1906. godine započela je izgradnja termoelektrane s dva turbogenerators. Početak 20. stoljeća veže se i uz pojavu električnog tramvaja koji je povezivao željezničku stanicu Matulji s Opatijom i Lovranom.

#### Osnivanje Fakulteta

Tijekom pedesetih godina prošlog stoljeća riječko je područje bilo najrazvijenije industrijsko područje na jadranskoj obali na kojem su poslovala brojna poduzeća: brodograđevna industrija s brodogradilištima 3. MAJ, Kraljevica, Viktor Lenac, Martinšćica i Kantrida, tvornice Torpedo, Vulkan, Rikard Benčić, Svjetlost (kasnije Rade Končar), Tvornica papira – Hartera, drvna i predaivačka industrija te rafinerija nafte koja je od 1964. godine u sastavu poduzeća INA.

Zbog potrebe školovanja takvog visokoobrazovanog kadra nije bila dovoljna samo jedna visokoškolska ustanova, Strojarsko-brodograđevni fakultet u Zagrebu, 1967. godine preimenovan u Fakultet strojarstva i brodogradnje. Savjet za prosvjetu kotara Rijeka na svojoj sjednici 27. travnja 1959. godine pokrenuo je pitanje osnivanja Visoke tehničke škole u Rijeci. Iste te godine, 30. srpnja, Kotarsko vijeće i Vijeće proizvođača raspravljalo je o tome na svojim sjednicama te je Narodni odbor kotara Rijeka zaključio potrebu osnivanja Strojarskog fakulteta u Rijeci. S obzirom na gospodarsku razvijenost riječke regije, zaključilo se kako je potreban kadar, u vidu izvršnih stručnjaka, dostupan. Imenovan je poseban odbor, kasnije preimenovan u Komisiju za osnivanje Strojarskog fakulteta u Rijeci, sa zadaćom pripreme potrebne dokumentacije. Elaborat o osnivanju Strojarskog fakulteta u Rijeci dostavljen je Izvršnom vijeću Narodne Republike Hrvatske 23. siječnja 1960. godine, a 20. veljače

of Europe. The first oil refinery in Croatia, as one of the first in Europe, was founded in 1882 and started operating in 1883 in Rijeka. The construction of the refinery was led by Milutin Barač, who with his solutions greatly improved the processing of crude oil and its derivatives. The street where the Oil Refinery's Plant and Administrative Building were located still bears his name.

Back in 1852, the first gas company started operating in Rijeka. At that time, Rijeka was illuminated with 226 gas lamps. The use of gas expanded rapidly, so as early as 1856, gas lighting was introduced in the city theatre. At

the end of the 19th century, the first power plants were built, which were extremely important as a source of energy for the operation of machines in workshops, for public lighting of town squares and roads, lighting of certain public buildings and in households. In Rijeka, a public power plant with three alternating single-phase electricity generators was built in 1892, and in 1906 the construction of a thermal power plant with two turbo-generators began. The beginning of the 20th century is also associated with the appearance of an electric tram that connected the Matulji railway station with Opatija and Lovran.

#### Foundation of the Faculty

During the fifties of the last century, the area of Rijeka was the most developed industrial area on the Adriatic coast where many companies operated: shipbuilding industry with shipyards 3. MAJ, Kraljevica, Viktor Lenac, Martinšćica and Kantrida, factories Torpedo, Vulkan, Rikard Benčić, Svjetlost (later Rade Končar), Paper Factory - Hartera, wood and refining industry and oil refinery, which has been part of INA since 1964.

Due to the need to train such highly educated staff, only one higher educational institution did not suffice - the Mechanical-Shipbuilding Faculty in Zagreb, which in 1967 was renamed the Faculty of Mechanical Engineering and Naval Architecture. At its session on 27 April 1959, the Council for Education of the Rijeka District raised the issue of the establishment of the Technical high school in Rijeka. On 30 July of the same year, the District Council and the Manufacturers' Council discussed this at their sessions, and the National Committee of the Rijeka



dostavljen je i dopunski elaborat. Elaborat je sadržavao obveze Narodnog odbora kotara Rijeka: na raspolaganje će se staviti zgrada Đačkog doma muške srednjoškolske omladine (današnja južna zgrada Fakulteta), bit će odobrena financijska sredstva za adaptaciju i uređenje zgrade i nabavu potrebne opreme, osigurat će se stanovi za nastavno osoblje, a u domu će biti osiguran smještaj za najmanje jednu četvrtinu studenata. Budući da se nije mogao odmah naći smještaj svih učenika Đačkog doma, u lipnju 1960. godine započela je adaptacija zgrade budućeg Fakulteta, ali samo istočnoga dijela. Interes Rijeke za pružanjem povoljnih uvjeta za rad Fakulteta te pozitivna društvena i politička klima o osnivanju fakulteta i izvan Zagreba, doprinijeli su prijedlogu Izvršnoga vijeća Narodne Republike Hrvatske koji 22. lipnja 1960. godine predlaže Saboru Narodne Republike Hrvatske donošenje odluke o osnivanju Strojarskoga fakulteta u Rijeci.

Sabor je 7. srpnja 1960. godine donio Zakon o osnivanju Strojarskoga fakulteta u Rijeci, Elektrotehničkoga i Kemijsko-tehnološkog fakulteta u Splitu i Visoke poljoprivredne škole u Osijeku. Taj je zakon stupio na snagu 11. kolovoza 1960. godine. U srpnju 1960. godine, Sveučilišni savjet Sveučilišta u Zagrebu raspisao je prvi natječaj za popunjenje mjesta nastavnika i asistenata na Strojarskom fakultetu u Rijeci. U svega četiri mjeseca od odluke Sabora, u Rijeci je djelomično adaptiran istočni dio zgrade Fakulteta, nabavljena je oprema i namještaj, formiralo se nastavničko vijeće Fakulteta i katedre, izabran je tajnik i drugo potrebno osoblje te je upisana prva generacija studenata u ak. god. 1960./1961. materijalna sredstva osigurala su riječka poduzeća i Narodni odbor kotara Rijeka.

Svečano otvorenje Strojarskoga fakulteta u Rijeci održano je 8. studenoga 1960. godine čemu su prisustvovali brojni predstavnici društvenopolitičkih i privrednih organizacija iz Rijeke i Pule, rektor Sveučilišta u Zagrebu, dekani i predstavnici fakulteta u Rijeci i Zagrebu i mnogi drugi. Nastava je na Strojarskom fakultetu u Rijeci započela 9. studenog 1960. godine.

Od 1960. do 1969. godine na Fakultetu se izvodio samo studij strojarstva. Od ak. god. 1969./1970. školuju se i diplomirani inženjeri brodograđevni fakultet. Pod ovim imenom djeluje do 1973. godine kada je preimenovan u Tehnički fakultet. Fakultet je ak. god. 1971./1972. započeo s izvođenjem nastave na studiju građevinarstva, koji se 1976. godine, osnivanjem Građevinskog fakulteta, odvaja u samostalnu organizaciju. Od 1973. godine Fakultet je u sastavu novoosnovanog Sveučilišta u Rijeci, čiji je prvi rektor bio prof. dr. sc. Zorislav Sapunar s Tehničkog fakulteta. Fakultet 1987. godine otvara stručni studij elektrotehnike te je tada upisana i prva genera-

District decided that the Faculty of Mechanical Engineering should be established in Rijeka. Given the economic development of the region of Rijeka, it was concluded that the necessary staff in the form of excellent experts was available. A special committee was appointed, which was later renamed the Commission for the Establishment of the Faculty of Mechanical Engineering in Rijeka, with the task of preparing the necessary documentation. The expertise on the establishment of the Faculty of Mechanical Engineering in Rijeka was submitted to the Executive Council of the National Republic of Croatia on 23 January 1960, and a supplementary expertise was submitted on 20 February. The expertise contained the obligations of the National Committee of the District of Rijeka: the building of the Dormitory for Male High School Youth (today's southern building of the Faculty) would be made available, financial resources would be approved for adaptation and arrangement of the building and procurement of necessary equipment, accommodation for the teaching staff would be assured and accommodation would be provided in the dormitory for at least one quarter of the students. Since it was not possible to immediately find accommodation for all the students of the dormitory, the adaptation of the building of the future Faculty began in June 1960, but only its eastern part. Rijeka's interest in providing favourable conditions for the work of the Faculty and the positive social and political climate for the establishment of faculties outside Zagreb contributed to the fact that the Executive Council of the National Republic of Croatia proposed to the Parliament of the National Republic of Croatia to issue the decision for establishing the Faculty of Mechanical Engineering on 22 June 1960.

On 7 July 1960, the Parliament passed the Law on the Establishment of the Faculty of Mechanical Engineering in Rijeka, the Faculty of Electrical Engineering and the Faculty of Chemical Technology in Split and the Agricultural high school in Osijek. This law came into force on 11 August 1960. In July 1960, the University Council of the University of Zagreb announced the first competition to fill the positions of teachers and assistants at the Faculty of Mechanical Engineering in Rijeka. In just four months from the decision of the Parliament, the eastern part of the Faculty building in Rijeka was partially renovated, equipment and furniture were procured, the Faculty Council and the departments were formed, a secretary and other necessary staff were elected and the first generation of students was enrolled in the 1960/1961 academic year. Material funds were provided by companies from Rijeka and the National Committee of the Rijeka District.

The grand opening of the Faculty of Mechanical

cija studenata tog studija, a 1999. započinje se s izvođenjem nastave i na sveučilišnom studiju elektrotehnike. Sveučilišni studij računarstva uvodi se 2008. godine, isprva na preddiplomskoj razini, a od 2011. g. i na diplomskoj razini. Time Fakultet postaje jedina visokoobrazovna institucija u Republici Hrvatskoj koja objedinjuje ova četiri studija.

Poslijediplomska se nastava na Fakultetu počela izvoditi 1971. godine kroz poslijediplomski magistrski studij, a doktorat znanosti se tada stjecao izvan doktorskog studija. Prvi doktorat znanosti obranjen je na Fakultetu 1974. godine. Doktorski studij ustrojen je 1999. godine, a periodično se osuvremenjuje sukladno napretku znanosti i tehnologije, pa je tako posljednja izmjena i dopuna odnosno osuvremenjivanje poslijediplomskih doktorskih studija provedeno u ak. god. 2019./2020.

#### Prostor Fakulteta

U početku Fakultet djeluje samo u istočnom dijelu današnje južne zgrade, ukupne površine 2570 m<sup>2</sup>, što je bilo dovoljno s obzirom na broj nastavnika i administracije te za potrebe izvođenja nastave. Zapadno krilo, u kojem je bio Đački dom, oslobađalo se postupno te je nakon tri godine od osnutka Fakultet dobio na raspolaganje treći kat zapadnog krila. Ukupna površina zgrade Fakulteta, po završetku građevinskih radova, iznosila je 7531 m<sup>2</sup>.

Nakon osnivanja Fakulteta pristupilo se izradi projektnog prijedloga za izgradnju zgrade laboratorija (sjeverna zgrada). Gradnja zgrade la-

Engineering in Rijeka was held on 8 November 1960, attended by numerous representatives of socio-political and economic organisations from Rijeka and Pula, the rector of the University of Zagreb, deans and representatives of the faculties in Rijeka and Zagreb and many others. Classes began at the Faculty of Mechanical Engineering in Rijeka on 9 November 1960.

From 1960 to 1969, only the study of mechanical engineering was conducted at the Faculty. As of the 1969/1970 academic year, graduate naval architects were educated, thus the Faculty changed its name into the Faculty of Mechanical Engineering and Naval Architecture. It operated under this name until 1973, when it was renamed the Faculty of Engineering. As of the 1971/1972 academic year, the Faculty began teaching civil engineering, which in 1976, with the founding of the Faculty of Civil Engineering, separated into an independent organisation. Since 1973, the Faculty has been part of the newly established University of Rijeka, whose first rector was Prof D. Sc. Zorislav Sapunar from the Faculty of Engineering. In 1987, the Faculty started the vocational study of Electrical Engineering, and the first generation of students of that study enrolled. Moreover, in 1999, classes began at the university study of Electrical Engineering. The university study of Computer Engineering was introduced in 2008, initially at the undergraduate level, and since 2011 at the graduate level. Thus, the Faculty has become the only higher educational institution in the Republic of Croatia that combines these four studies.



boratorija započela je u kolovozu 1964. godine, nakon odobrene polovice iznosa traženih sredstva mjerodavnog republičkog tijela, a završena je krajem 1966. godine. Zgrada laboratorija površine je 6407 m<sup>2</sup>. Krajem devedesetih godina prošlog stoljeća uložila su se znatna sredstva u opremu za zavode, laboratorije i praktikume unutar pojedinih zavoda.

U razdoblju od 2002. do 2005. godine na Fakultetu su izvedeni mnogobrojni investicijski zahvati kako bi se osigurao prostor za neometano odvijanje nastavnih i znanstvenoistraživačkih aktivnosti. Nadogradnja fakulteta izvodila se u nekoliko faza: u prvoj fazi izvršena je rekonstrukcija kanalizacije, izgradnja protupožarne hidrantske mreže, rekonstrukcija kotlovnice za prijelaz na plinovito gorivo te izgradnja gromobranskog uzemljenja. Druga faza obuhvatila je građevinske i obrtničke radove i uređenje fasade južne zgrade, a u trećoj je nabavljena laboratorijska i informatička oprema i namještaj. Fakultet je nadogradnjom dobio 2854 m<sup>2</sup> novog prostora, južna zgrada i zgrada laboratorija povezane su mostom, a izgrađeno je i vanjsko protupožarno stubište. Ukupni prostor Fakulteta postaje bogatiji za dvije velike predavaonice sa 128 mjesta s opremom za održavanje udaljenih predavanja koje se, po potrebi, mogu spojiti u jednu dvostruko veću, a čine ga i dvije predavaonice sa 142 i 122 mjesta, 16 manjih predavaonica i učionica, 11 informatičkih učionica s ugrađenom opremom, laboratorijski prostori, nova knjižnica s arhivom knjiga, oko 150 kancelarijskih prostorija, studentska blagovaonica s moderno uređenom kuhinjom, prostorije za studentske organizacije i mnoge druge. Brojne prostorije u starom dijelu zgrade Fakulteta preuređene su i opremljene kako bi zadovoljile potrebe odvijanja nastavnih i znanstvenoistraživačkih aktivnosti. Također, 50 godina od osnutka Fakulteta u južnoj je zgradi dograđen lift.

#### Fakultet danas

Tijekom šest desetljeća svojega djelovanja, Tehnički fakultet se pozicionirao kao prepoznatljiva institucija na hrvatskoj i međunarodnoj znanstvenoj i visokoobrazovnoj sceni. Fakultet je danas ustrojen kroz 11 zavoda, 36 katedri i 50 laboratorija, a zajedno sa stručnim službama, Računalnim centrom te Knjižnicom, Fakultet danas predstavlja modernu visokoškolsku i znanstvenu instituciju.

Na Tehničkom fakultetu trenutno studira više od 1800 studenata. Nastava se izvodi na 14 studijskih programa: preddiplomskim i diplomskim sveučilišnim studijima strojarstva, brodogradnje, elektrotehnike i računarstva, preddiplomskim stručnim studijima strojarstva, brodogradnje i elektrotehnike te poslijediplomskim doktorskim studijima iz područja tehničkih znanosti: posli-

Postgraduate teaching at the Faculty began in 1971 through postgraduate master's studies, and the doctorate of science was then acquired outside the doctoral study. The first doctorate of science was defended at the Faculty in 1974. The doctoral study was established in 1999 and it has been periodically updated in accordance with the progress of science and technology, so the last amendment or modernisation of postgraduate doctoral studies was carried out in the 2019/2020 academic year.

#### Faculty premises

Initially, the Faculty operated only in the eastern part of the today's southern building, with a total area of 2,570 m<sup>2</sup>, which was sufficient given the number of teachers, the administration and for the needs of teaching. The west wing, which housed the dormitory, was gradually vacated, and three years after its founding, the Faculty received the third floor of the west wing. The total area of the Faculty building after the completion of the construction works was 7,531 m<sup>2</sup>.

After the founding of the Faculty, a project proposal for the construction of a laboratory building (northern building) was drafted. The construction of the laboratory building began in August 1964, after half of the amount requested by the relevant republican body had been approved, and was completed in late 1966. The laboratory building area is 6,407 m<sup>2</sup>. In the late 1990s, significant funds were invested in the equipment for the departments, laboratories and practicums within individual departments.

In the period from 2002 to 2005, numerous investment interventions were carried out at the Faculty in order to provide space for the smooth running of the teaching and scientific research activities. The expansion of the Faculty was performed in several phases: in the first phase, the reconstruction of the sewerage system, the construction of a fire hydrant network, the reconstruction of the boiler-room for the transition to gaseous fuel and the construction of the lightning rod protection. The second phase included the construction and craft works as well as the arrangement of the facade of the southern building, while in the third phase, the laboratory and IT equipment and furniture were procured. The expansion gave the faculty 2,854 m<sup>2</sup> of new space, the south building and the laboratory building were connected by a bridge, and an external fire escape was built. The total space of the Faculty has become richer for two large lecture halls with 128 seats with the equipment for remote lectures that can be combined into one twice as large lecture hall. It also consists of two lecture halls with 142 and 122 seats, 16 smaller lecture halls and classrooms, 11 IT classrooms with built-in equipment, laboratory spaces, a



jediplomskom doktorskom studiju koji obuhvaća znanstvena polja strojarstva, brodogradnje, temeljnih i interdisciplinarnih tehničkih znanosti, poslijediplomskom doktorskom studiju iz polja elektrotehnike te poslijediplomskom doktorskom studiju iz polja računarstva.

Do danas je na Tehničkom fakultetu Sveučilišta u Rijeci diplome steklo oko 8500 studenata, 95 kandidata steklo je zvanje magistra znanosti, dok je 149 kandidata obranilo doktorske disertacije i steklo zvanje doktora znanosti. Ti podaci govore da je na Fakultetu, otkako je osnovan, školovana većina visokoobrazovanih stručnjaka tehničkog profila naše uže i šire regije, čime je izravno pridonio, kako razvitku grada Rijeke i Primorsko-goranske županije, tako i razvoju Hrvatske u cjelini.

Istraživačka djelatnost Fakulteta provodi se u okviru brojnih znanstvenih projekata financiranih od strane resornog ministarstva, Hrvatske zaklade za znanost, Sveučilišta u Rijeci, bilate-

new library with an archive of books, about 150 office rooms, a student dining room with a modern kitchen, rooms for student organisations and many others. Numerous rooms in the old part of the Faculty building have been renovated and equipped to meet the needs of teaching and research activities. Also, 50 years from the establishment of the Faculty, an elevator was added to the southern building.

#### The Faculty today

During the six decades of its activity, the Faculty of Engineering has positioned itself as a recognizable institution on the Croatian and international scientific and higher educational scene. Today, the Faculty is organized through 11 departments, 36 chairs and 50 laboratories, and together with the professional services, the computer centre and the library, the Faculty today represents a modern higher educational and scientific institution.



## AI & Learning

John McCarthy (1927-2011) coined the term **artificial intelligence** in 1955 with "some aspect of learning or any other feature of intelligence can in principle be so precisely described that a machine can be made to simulate it"



AI? I do not accept the premise that we can describe learning.

Machine learning is a collection of computer methods that we extract information from data using optimization techniques like hill climbing, other related to the backpropagation learning, gradient descent, or through self-organization, or reinforcement, and also that learning - more interesting



ralnih projekata sa znanstvenim institucijama iz međunarodnog okruženja te niza međunarodnih znanstvenih izvora financiranja koji podržavaju znanstvenu izvrsnost (Horizon 2020, OPKK, COST, ERASMUS, CEEPUS). U okviru međunarodne suradnje, Tehnički fakultet surađuje s približno stotinjak institucija diljem svijeta (Europa, Australija, SAD, Azija).

Za istaknuti je i nekoliko provedenih istraživačkih projekata kao i veliki broj stručnih projekata u suradnji s gospodarstvom. Kako bi se dodatno potaknula suradnja s gospodarstvom, 2018. godine osnovan je i Gospodarski savjet Tehničkog fakulteta, sastavljen od predstavnika gospodarstvenika iz svih polja djelovanja Fakulteta.

Znanstveni rad i postignuti rezultati nisu ostali nezapaženi, o čemu svjedoče ugledne nagrade i priznanja koje su djelatnici Tehničkog fakulteta dobili za svoja postignuća. Tako su, primjerice, znanstvenici Fakulteta bili dobitnici državne nagrade za životno djelo u području tehničkih znanosti, nagrade Hrvatske akademije znanosti i umjetnosti za najviša znanstvena i umjetnička postignuća u Republici Hrvatskoj, nagrade za mlade znanstvenike Vera Johanides Hrvatske akademije tehničkih znanosti, nagrade za životno djelo Primorsko-goranske županije, nagrade Zaklade Sveučilišta u Rijeci za područje tehničkih i prirodnih znanosti, godišnje nagrade Grada Rijeke za izniman i prepoznatljiv doprinos razvoju, unaprjeđenju i popularizaciji znanosti, a brojni su i studenti koji su za svoje iznimne rezultate u studiranju na zahtjevnim studijima Tehničkog fakulteta bili nagrađeni rektorovim nagradama.

More than 1,800 students are currently studying at the Faculty of Engineering. Teaching is conducted in 14 study programmes: undergraduate and graduate university studies in mechanical engineering, naval architecture, electrical engineering and computer engineering, undergraduate vocational studies in mechanical engineering, naval architecture and electrical engineering as well as postgraduate doctoral studies in engineering sciences: postgraduate doctoral study in the scientific fields of mechanical engineering, naval architecture, fundamental and interdisciplinary engineering sciences, postgraduate doctoral study in the scientific field of electrical engineering and postgraduate doctoral study in the scientific field of computer engineering.

To date, about 8,500 students have graduated from the Faculty of Engineering of the University of Rijeka, 95 candidates have obtained the title of Master of Science, while 149 candidates have defended their doctoral theses and obtained the title of Doctor of Science. These data show that since its founding, the Faculty has educated the majority of highly educated engineering experts in this area and wider, which has directly contributed to the development of the city of Rijeka and the Primorje – Gorski Kotar county and the development of Croatia as a whole.

The research activity of the Faculty has been carried out within numerous scientific projects funded by the relevant ministry, the Croatian Science Foundation, the University of Rijeka, bilateral projects with scientific institutions from the international environment and a number of



U cilju diseminacije rezultata istraživanja, Fakultet 1970. godine započinje s izdavanjem Zbornika radova, koji od 1995. godine izlazi kao znanstveni časopis Engineering Review. Od 2011. godine časopis se izdaje u suradnji s Građevinskim fakultetom Sveučilišta u Rijeci. Časopis je indeksiran u brojnim bazama, uključujući i SCImago, SCOPUS te Web of Science.

Od svog osnutka, Fakultet je organizator ili suorganizator brojnih znanstvenih i stručnih skupova, simpozija, konferencija i savjetovanja između kojih je za istaknuti konferenciju za studente doktorskih studija inženjerstva Sveučilišta u Rijeci, My First Conference. Konferenciju su osmislili i pokrenuli djelatnici Tehničkog fakulteta, a održava se u suorganizaciji s Pomorskim i Građevinskim fakultetom Sveučilišta u Rijeci. Na konferenciji se ističe izuzetna aktivnost doktoranada, njihova samoinicijativnost, kreativnost i samostalnost u istraživanjima. Pokazalo se kako su naši doktorandi i sami doktorski studiji vrlo svestrani, interdisciplinarni i na visokoj razini kvalitete.

U posljednjih deset godina Fakultet ulaže značajna vlastita sredstva u nabavku laboratorijske opreme kako bi se znanstvenicima i studentima omogućio rad i osposobljavanje u suvremenom laboratorijskom okruženju. Tome treba pridodati i laboratorijsku opremu pribavljenu sredstvima istraživačkih projekata, a koja upotpunjuje raspoloživost i značajno povećava istraživačke kapacitete Fakulteta.

Posebno je potrebno istaknuti i ulaganje u informatičku opremu i infrastrukturu. Fakultetske informatičke učionice opremljene su suvremenom

international scientific funding sources that support scientific excellence (Horizon 2020, OPKK, COST, ERASMUS, CEEPUS). As part of international cooperation, the Faculty of Engineering has been cooperating with approximately one hundred institutions around the world (Europe, Australia, USA, Asia).

Several research projects should be highlighted, as well as a large number of professional projects in cooperation with the economy. In order to further encourage cooperation with the economy in 2018, the Economic Council of the Faculty of Engineering was established, composed of representatives of the economy from all fields of activity of the Faculty.

That the scientific work and the achieved results did not go unnoticed is also shown by the prestigious awards and recognitions that the employees of the Faculty of Engineering received for their achievements. Thus, for example, the scientists of the Faculty were winners of the state award for lifetime achievement in the field of engineering sciences, the award of the Croatian Academy of Science and Arts for the highest scientific and artistic achievements in the Republic of Croatia, the award for young scientists Vera Johanides of the Croatian Academy of Engineering Sciences, awards for lifetime achievement of the Primorje – Gorski kotar county, awards of the Foundation of the University of Rijeka for engineering and natural sciences, annual awards of the City of Rijeka for exceptional and recognisable contribution to the development, improvement and popularisation of science. A



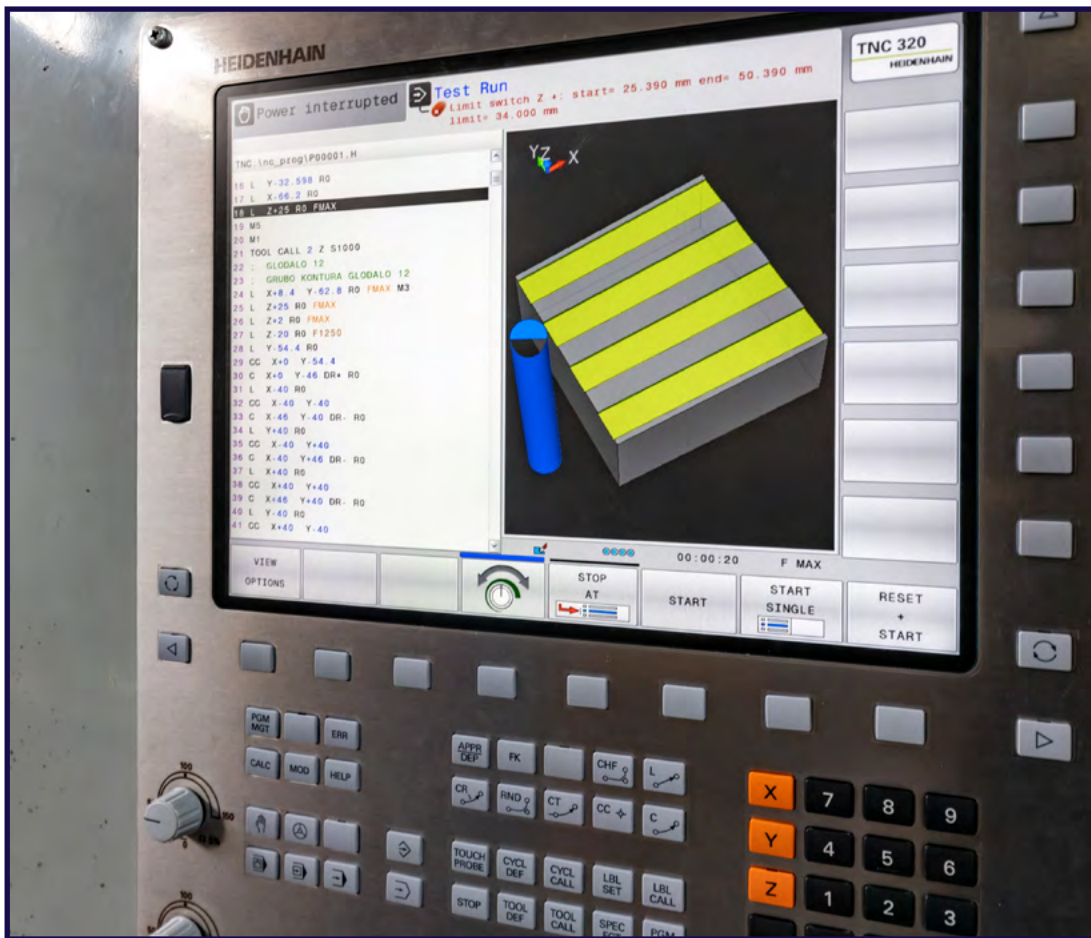

Za istaknuti je i aktivnosti fakultetskog Alumni kluba koji okuplja doktore i magistre znanosti i diplomirane inženjere i inženjere koji su ta zvanja stekli na Tehničkom fakultetu.

Sa svojih 180 djelatnika među kojima 85 ima stupanj doktora znanosti, Tehnički fakultet zasigurno predstavlja jednu od najvažnijih sastavnica Sveučilišta u Rijeci, a o kvaliteti rada i djelovanja na Fakultetu govore i certifikati kvalitete dodijeljeni od neovisnih ocjenjivačkih tijela i povjerenstava, primjerice certifikat Agencije za znanost i visoko obrazovanje kojim se potvrđuje da je sustav osiguravanja kvalitete Tehničkog fakulteta učinkovit i u skladu s nacionalnim standardima i standardima i smjericama za osiguravanje kvalitete u europskom prostoru visokog obrazovanja, certifikat sustava upravljanja kvalitetom prema normi ISO 9001, pozitivni ishodi većeg broja akreditacija i reakreditacija provedenih na našem Fakultetu i druge.

Svi navedeni rezultati, ali i svi oni koji ovdje nisu spomenuti, nepobitno govore o bogatoj i širokoj lepezi aktivnosti koje se godinama odvijaju na i oko Tehničkog fakulteta i čine akademski život na Fakultetu interesantnim, izazovnim i poticajnim za sve učesnike i osiguravaju prepoznatljivost Tehničkog fakulteta kao mjesto, danas i ubuduće, poželjno za studiranje i znanstvenistraživački rad.

of Rijeka. The conference highlights the exceptional activity of doctoral students, their self-initiative, creativity and independence in research. It has been proven that our doctoral students and the doctoral studies themselves are very versatile, interdisciplinary and at a high level of quality.

In the last ten years, the Faculty has been investing significant own funds in the procurement of laboratory equipment in order to enable scientists and students to work and practice in a modern laboratory environment. To this should be added the laboratory equipment obtained with the funds of research projects, which completes the availability and significantly increases the research capacities of the Faculty.

The investment in IT equipment and infrastructure should be particularly emphasised. The IT classrooms are equipped with modern computer equipment, a fast internet network has been established enabling all employees to work and use network resources. Furthermore, the Faculty also has a 3D Experience STEM laboratory, equipped with modern equipment for product design and development.

A rich student life takes place at the Faculty. Students actively participate in the Student Council, and they organise their activities through the associations IAESTE, IEEE, AAEGE, Association of Mechanical Engineering Students Rijeka, etc. Very notable results have been achieved by the



računalnom opremom, uspostavljena je brza internetska mreža koja omogućuje svim djelatnicima nesmetani rad i korištenje mrežnih resursa, a na Fakultetu djeluje i 3D Experience STEM laboratorij, opremljen suvremenom opremom za konstruiranje i razvoj proizvoda.

Na Fakultetu se odvija i bogat studentski život. Studenti su organizirani kroz Studentski zbor, a svoje aktivnosti organiziraju i putem udruga IAESTE, IEEE, AAEGE, Udrugu studenata strojarstva Rijeka i druge. Vrlo zapažene rezultate postižu studenti Fakulteta organizirani kroz tematske timove i to Riteh Racing Team, Waterbike Team, Riteh Web Team, Riteh Drone Team. Studenti i djelatnici Tehničkog fakulteta aktivni su i u sportskim aktivnostima na kojima postižu zapažene rezultate.

U cilju podizanja razine kvalitete života studenata na Fakultetu, u suradnji sa Studentskim centrom Rijeka, u prostorima Fakulteta uređen je studentski restoran, Bistro RITEH, koji pruža i usluge subvencionirane studentske prehrane.

lot of students were also awarded with the rector's awards for their exceptional results in the demanding studies of the Faculty of Engineering.

In order to disseminate the results of the research, the Faculty began publishing the Proceedings in 1970, which has been published as the scientific journal Engineering Review since 1995. Since 2011, the journal has been published in cooperation with the Faculty of Civil Engineering, University of Rijeka. The journal is indexed in a number of databases including SCImago, SCOPUS and Web of Science.

Since its founding, the Faculty has been the organiser or co-organiser of numerous scientific and professional gatherings, symposia and conferences, among which My First Conference is a prominent conference for doctoral students of engineering at the University of Rijeka. This conference was designed and initiated by the staff of the Faculty of Engineering, and is held in co-organisation with the Faculty of Maritime Studies and the Faculty of Civil Engineering, University

SVEUČILIŠTE U RIJECI  
TEHNIČKI FAKULTET

58





students of the Faculty organised through thematic teams, namely Riteh Racing Team, Water-bike Team, Riteh Web Team, Riteh Drone Team.

Students and staff of the Faculty of Engineering are also active in sports activities where they have achieved notable results.

In order to raise the level of students' quality of lives at the Faculty, in cooperation with the Student Centre Rijeka in the premises of the Faculty a student restaurant, Bistro RITEH, has been arranged, which also provides services of subsidised student meals.

The activities of the Faculty Alumni Club, which brings together doctors and masters of science as well as graduate engineers and engineers who have acquired these titles at the Faculty of Engineering are also noteworthy.

With its 180 employees, 85 of whom have a PhD, the Faculty of Engineering is certainly one of the most important constituent institutions of the University of Rijeka, and the quality of work and activities at the Faculty is evidenced by quality certificates awarded by independent evaluating bodies and committees, such as the Agency for Science and Higher Education, which confirmed that the quality assurance system of the Faculty of Engineering is effective and in accordance with national standards and standards and guidelines for quality assurance in the European Higher Education Area, quality management system certificate according to ISO 9001, positive outcomes of several accreditations and re-accreditations conducted at our Faculty, and others.

All the above results, but also all those not mentioned here, unequivocally speak of the rich and wide range of activities that take place over and around the Faculty of Engineering and make academic life at the Faculty interesting, challenging and stimulating for all participants. They also ensure the visibility of the Faculty of Engineering as a desirable place for study and scientific research today and in the future.

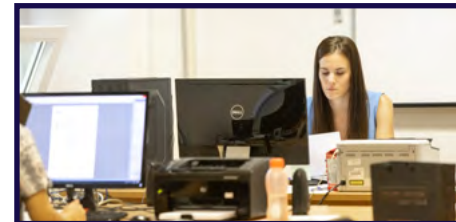



# 1 opće informacije general information

Tehnički fakultet Sveučilišta u Rijeci stožerna je visokoškolska i znanstveno-istraživačka institucija na području tehničkih znanosti ne samo na Sveučilištu u Rijeci nego i u regiji u kojoj djeluje, konkurentna na europskom i svjetskom tržištu znanja. Fakultet objedinjuje danas djelatnost 11 zavoda, i to:

The Faculty of Engineering of the University of Rijeka is a leading higher education, scientific and research institution in the field of engineering sciences not only at the University of Rijeka, but also in the region where is situated. It is competitive on the European and the world knowledge market. The Faculty encompasses 11 departments, namely:

- » Zavoda za automatiku i elektroniku  
Department of Automation and Electronics
- » Zavoda za brodogradnju i inženjerstvo morske tehnologije  
Department of Naval Architecture and Ocean Engineering
- » Zavoda za elektroenergetiku  
Department of Electrical Power Engineering
- » Zavoda za industrijsko inženjerstvo i management  
Department of Industrial Engineering and Management
- » Zavoda za konstruiranje u strojarstvu  
Department of Mechanical Engineering Design
- » Zavoda za matematiku, fiziku, strane jezike i kineziologiju  
Department of Mathematics, Physics, Foreign Languages and Kinesiology
- » Zavoda za materijale  
Department of Materials Science and Engineering
- » Zavoda za mehaniku fluida i računarsko inženjerstvo  
Department of Fluid Mechanics and Computational Engineering
- » Zavoda za računarstvo  
Department of Computer Engineering
- » Zavoda za tehničku mehaniku  
Department of Engineering Mechanics
- » Zavoda za termodinamiku i energetiku  
Department of Thermodynamics and Energy Engineering

U sklopu zavoda djeluje 36 katedri i 50 laboratorija, a na Fakultetu djeluju i Računalni centar, Knjižnica, te Financijska služba, Služba nabave i komercijale, Služba općih i kadrovskih poslova, Služba studentske evidencije i Tehnička služba. Od 183 zaposlenika 84 ih je u znanstveno-nastavnim, 7 u nastavnim i 41 u suradničkim zvanjima, 2 je zaposlenika na projektima Hrvatske zaklade za znanost, a 42 je djelatnika u administrativnim i stručnim službama. Na DATACROSS projektima i EU projektima je zaposleno 7 djelatnika. Na Fakultetu radi i veći broj vanjskih suradnika. Fakultet izvodi sveučilišne preddiplomske i sveučilišne diplomске studijske programe na području strojarstva, brodogradnje, elektrotehnike i računarstva te stručne preddiplomske studijske

The departments include 36 sections and 50 laboratories, and the Faculty also has a Computing Centre, a Library as well as an Accounting Division, Procurement Office, the General and Personnel Office, the Student Affairs Office and the Technical Service. Of the total number of 183 employees, 84 are in teaching-research, 7 in teaching and 41 in associate positions, 2 members of staff work on projects funded by the Croatian Science Foundation, and 42 work in the administrative and professional services. Seven members of staff work on DATACROSS projects and EU projects. The Faculty engages a large number of external associates. The Faculty offers undergraduate and graduate university study

programme na području strojarstva, brodogradnje i elektrotehnike, kao i trogodišnji treći ciklus obrazovanja koji omogućava stjecanje doktorata znanosti na području tehničkih znanosti, i to na polju strojarstva, brodogradnje, elektrotehnike, temeljnih tehničkih znanosti, interdisciplinarnih tehničkih znanosti te računarstva.

Do sada je na Tehničkom fakultetu u Rijeci diplome steklo 149 doktora znanosti, 95 magistara znanosti, 2899 diplomiranih inženjera (od čega 2335 strojarstva, 311 brodogradnje i 253 elektrotehnike), 1536 inženjera (od čega 717 strojarstva, 108 brodogradnje i 711 elektrotehnike), 1521 magistra inženjera (od čega 675 strojarstva, 121 brodogradnje, 545 elektrotehnike i 180 računarstva), 2111 sveučilišnih prvostupnika inženjera (od čega 1025 strojarstva, 153 brodogradnje, 608 elektrotehnike i 325 računarstva) te 699 stručnih prvostupnika inženjera (od čega 282 strojarstva, 63 brodogradnje i 354 elektrotehnike). Danas tu studira oko 2000 studenata.

Tehnički fakultet ima dugu tradiciju izdavanja znanstvenih i stručnih radova. Tiskanje Zbornika radova započinje još 1970. godine, a 1988. godine spomenuta edicija mijenja naziv u Zbornik Tehničkog fakulteta Rijeka. Naziv se ponovo mijenja 1995. godine u Engineering Review, a pod tim nazivom časopis se tiska i danas. Osim znanstvenih i stručnih radova, djelatnici Fakulteta objavili su i mnogobrojne knjige i udžbenike.

Na Fakultetu je od 24. studenog 2000. godine aktivan Alumni klub Tehničkoga fakulteta Sveučilišta u Rijeci (skraćeno ALUMNI TFR) osnovan s primarnim ciljem izgradnje i jačanja veza i suradnje između bivših studenata i Tehničkoga fakulteta, ali i osobne suradnje između bivših studenata. Predsjednik ALUMNI TFR je doc. dr. sc. Vedran Kirinčić.

Dobrovoljno darivanje krvi na Fakultetu provodi se još od 1980. godine. U novije doba ta hvaljevrijedna aktivnost provodi se organizirano od 2002. godine. U akademskoj godini 2019./2020. smo održali 3 akcije (21.10.2019., 14.1.2020. i 12.5.2020. (na Transfuziologiji u organizaciji Tehničkog fakulteta)) pri čemu je prikupljeno oko 120 doza ove dragocjene tekućine. Proteklih godina glavni organizator darivanja krvi je prof. dr. sc. Roberto Žigulić, a pomažu mu i članovi Kluba 25. Krv u podjednakom broju daruju i zaposlenici i studenti.

Na TFR od 1990. godine djeluje i podružnica Nezavisnog sindikata znanosti i visokog obrazovanja. Osim zaštite prava svojih članova, sindikalna podružnica na Fakultetu obavlja i zadatke iz djelokruga rada Zaposleničkoga vijeća koje na fakultetu nije konstituirano. Sindikalni povjerenici Podružnice su prof. dr. sc. Roberto Žigulić iz redova nastavnoga osoblja i Žarko Burić iz redova nenastavnoga osoblja.

programmes in mechanical engineering, naval architecture, electrical engineering and computer engineering as well as undergraduate vocational study programmes in mechanical engineering, naval architecture and electrical engineering. It also offers a three-year doctoral study in the area Engineering Sciences, in the fields of Mechanical Engineering, Naval Architecture, Electrical Engineering, Fundamental Engineering Sciences, Interdisciplinary Engineering Sciences and Computer Sciences.

So far, the Faculty of Engineering in Rijeka has delivered 149 D. Sc. and 95 Master of Science degrees. Of the former 2899 Graduate Engineer Diplomas 2335 were in Mechanical Engineering, 311 in Naval Architecture and 253 in Electrical Engineering; and of 1536 Engineer Diplomas 717 were in Mechanical Engineering, 108 in Naval Architecture and 711 in Electrical Engineering. The Bologna programme has produced 1521 Master Engineers (675 Mechanical Engineering, 121 Naval Architecture, 545 Electrical Engineering and 180 Computer Engineering), 2111 University Bachelor Engineers (1025 Mechanical Engineering, 153 Naval Architecture, 608 Electrical Engineering and 325 Computer Engineering) as well as 699 Vocational Bachelor Engineers (282 Mechanical Engineering, 63 Naval Architecture and 354 Electrical Engineering). At present around 2000 students study at the Faculty.

The Faculty of Engineering has a long tradition of publishing scientific and technical papers. Proceedings were first published as far back as in 1970, and as of 1988 under the name Proceedings of the Faculty of Engineering in Rijeka. In 1995, this was renamed into Engineering Review, which is still in use today. In addition to scientific and technical papers, the faculty staff has published numerous books and textbooks.

The Alumni Club of the Faculty of Engineering in Rijeka (ALUMNI TFR) was founded on 24th November 2000 with the primary aim of establishing and strengthening ties and cooperation not only between alumni and the Faculty but also among the alumni themselves. The chair of the ALUMNI TFR is Assist. Prof. D. Sc. Vedran Kirinčić.

Voluntary blood donation at the Faculty has been carried out since 1980. In recent times, this laudable activity has been carried out in an organized manner since 2002. In the academic year 2019/2020, three such events were organized (October 21 2019, January 14 2020 and May 12 2020 (at Transfusiology organized by the Faculty of Engineering)), where around 120 doses of this precious liquid were collected.

In recent years, the main organizer of the blood donation has been Prof. D. Sc. Roberto Žigulić, assisted by members of Club 25. The blood is being donated by equal number of staff and students.

Since 1990, a subsidiary of the Independent Union of Science and Higher Education Employees of Croatia has been active at the Faculty of Engineering. Apart from protecting the rights of its members, the union branch carries out tasks within the scope of Workers's Council, which has not been organized at the Faculty. The Union representatives of the Subsidiary are Prof. D. Sc. Roberto Žigulić, representing the teaching staff, and Žarko Burić the non-teaching staff.







TEHNIČKI FAKULTET RIJEKA
DEKAN
Prof. dr. sc. Duško PAVLETIĆ

URED DEKANA
VODITELJICA/UREDA
Sanja PRPIĆ

GLAVNI TAJNIK
Tomo VERGIĆ

TAJNICA PRODEKANA
Željka GULIĆ

PRODEKANI
Prof. dr. sc. Anica TRP
Prof. dr. sc. Marina FRANULOVIĆ
izv. prof. dr. sc. Ivan STAUDIHAH

POMOĆNICI DEKANA
izv. prof. dr. sc. Neven BIJIĆ
izv. prof. dr. sc. Marino BRČIĆ

KNIŽNICA
VODITELJICA
Sanja OREŠKOVIĆ

RAČUNALNI CENTAR
VODITELJ
Domagoj CRUJENKO

FINANCIJSKA SLUŽBA
VODITELJICA
Ana MIRKOVIĆ PAVLOVIĆ

SLUŽBA NABAVE I KOMERCIJALE
VODITELJ
Robert MOHORIĆ

SLUŽBA OPĆIH I KADROVSKIH POSLOVA
VODITELJICA
Marijana BURIĆ REDŽOVIĆ

SLUŽBA STUDENTSKE EVIDENCIJE
VODITELJ
Žarko BURIĆ

TEHNIČKA SLUŽBA
VODITELJ
Goran BAKOTIĆ

KNIŽNICA
DIP.L. KNIŽNIČAR
Mr. sc. Mario ŠOŠAR-BRNELIĆ

RAČUNALNI CENTAR
STRUČNI SURADNICI
Damir KOŠČIĆ
Tajana ŠKORJANEC

ODSEK KNJIGOVODSTVA
VODITELJ
Goran BRODARAC

ODSEK EKONOMATA
VODITELJ
Mladen OSTROGOVIĆ

KADROVSKI ODSEK
VODITELJICA
Snježana MIKULIĆ

SLUŽBA STUDENTSKE EVIDENCIJE
STRUČ. SURADNIK
Darko VIDUČIĆ

LABORATORIJ
LABORANTI
Bernardo BADOJINA
Nevo PONIS

RAČUNALNI CENTAR
TEHNIČKI SURADNIK
Siniša VUKOTIĆ

ODSEK FINANCIJSKE OPERATIVE
VODITELJICE
Ariana GREGUR
Ana ŠUTALO

ODSEK NABAVE
VODITELJICE
Tijana ČUPURDIJA
Bruna MARTINOVIC

KADROVSKI ODSEK
ADMIN. TAJNICE
Valtea BURIĆ MAROJNIĆ
Natalija FORGIĆ
Tina KAŽIĆ
Lovorka MALINIĆ
Patricija YUKIĆ

ODSEK STUDENTSKE REFERADE
Antonela ČALETA
Adriana MUŽDEKA PRODANOVIĆ
Tanja VELIČIĆ

RADIONICE ODRŽAVANJA
Josip JURASIĆ
Andrej MILUŠ

ZASTITA NA RADU
ZASTITA OD POŽARA
Goran BAKOTIĆ
Frane POLEGUBIĆ

PISMOHRANA-POŠTA
REFERENTICA
Lidija PETRIČIĆ

ODSEK OPĆIH POSLOVA
SPREMAČICE
Snježana BAN
Danijela ČUK
Marina DIAKOVIĆ
Marica GNAJTOVIĆ
Valentina KAJFEŠ
Mirjana KOŠPIĆ
Julijana NENADOVIĆ

ODSEK STUDENTSKE REFERADE
Antonela ČALETA
Adriana MUŽDEKA PRODANOVIĆ
Tanja VELIČIĆ

ZASTITA NA RADU
ZASTITA OD POŽARA
Goran BAKOTIĆ
Frane POLEGUBIĆ

KUĆEPAZITELJI
Miljenko PUJIĆ
Boris ŠEGOTA

### Organizacijska struktura Fakulteta - stručne službe

FACULTY OF ENGINEERING
DEAN
Prof. D. Sc. Duško PAVLETIĆ

DEAN'S OFFICE
OFFICE HEAD
Sanja PRPIĆ

SECRETARY GENERAL
Tomo VERGIĆ

VICE DEAN SECRETARY
Željka GULIĆ

VICE-DEANS
Prof. D. Sc. Anica TRP
Prof. D. Sc. Marina FRANULOVIĆ
Assoc. Prof. D. Sc. Ivan STAUDIHAH

DEAN'S ASSISTANTS
Assoc. Prof. D. Sc. Neven BIJIĆ
Assoc. Prof. D. Sc. Marino BRČIĆ

LIBRARY
HEAD
Sanja OREŠKOVIĆ

COMPUTER CENTER
HEAD
Domagoj CRUJENKO

ACCOUNTING DIVISION
HEAD
Ana MIRKOVIĆ PAVLOVIĆ

PROCUREMENT AND COMMERCIAL OFFICE
HEAD
Robert MOHORIĆ

GENERAL AND PERSONNEL OFFICE
HEAD
Marijana BURIĆ REDŽOVIĆ

STUDENTS' REGISTRAR AND AFFAIRS OFFICE
HEAD
Žarko BURIĆ

TECHNICAL AND MAINTENANCE SERVICES
HEAD
Goran BAKOTIĆ

LIBRARY
GRAD. LIBRARIAN
M. Sc. Mario ŠOŠAR-BRNELIĆ

COMPUTER CENTER
ASSOCIATES
Damir KOŠČIĆ
Tajana ŠKORJANEC

ACCOUNTING SECTION
HEAD
Goran BRODARAC

SUPPLIES SECTION
HEAD
Mladen OSTROGOVIĆ

PERSONNEL SECTION
HEAD
Snježana MIKULIĆ

STUDENTS' REGISTRAR AND AFFAIRS OFFICE
ASSOCIATE
Darko VIDUČIĆ

LABORATORY
LABORANTS
Bernardo BADOJINA
Nevo PONIS

COMPUTER CENTER
TECH. ASSOCIATE
Siniša VUKOTIĆ

FINANCIAL ACTIVITIES SECTION
HEAD
Ariana GREGUR
Ana ŠUTALO

PROCUREMENT SECTION
HEAD
Tijana ČUPURDIJA
Bruna MARTINOVIC

PERSONNEL SECTION
ADMIN. SECRETARIES
Valtea BURIĆ MAROJNIĆ
Natalija FORGIĆ
Tina KAŽIĆ
Lovorka MALINIĆ
Patricija YUKIĆ

STUDENTS' REGISTRAR AND AFFAIRS OFFICE
ASSOCIATE
Darko VIDUČIĆ

MAINTENANCE WORKSHOPS
Josip JURASIĆ
Andrej MILUŠ

OCCUPATIONAL SAFETY
FIRE SAFETY
Goran BAKOTIĆ
Frane POLEGUBIĆ

JANITORS
Miljenko PUJIĆ
Boris ŠEGOTA

GENERAL AFFAIRS SECTION
HOUSEKEEPERS
Snježana BAN
Danijela ČUK
Marina DIAKOVIĆ
Marica GNAJTOVIĆ
Valentina KAJFEŠ
Mirjana KOŠPIĆ
Julijana NENADOVIĆ

ARCHIVE AND MAIL SERVICES
REGISTRY CLERK
Lidija PETRIČIĆ

GENERAL AFFAIRS SECTION
HOUSEKEEPERS
Snježana BAN
Danijela ČUK
Marina DIAKOVIĆ
Marica GNAJTOVIĆ
Valentina KAJFEŠ
Mirjana KOŠPIĆ
Julijana NENADOVIĆ

## 2 fakultet u akademskoj godini 2019./2020. the faculty in the academic year 2019/2020

### 2.1 opće informacije general information

Na Tehničkom fakultetu tijekom akademske godine 2019./2020. u različitim fazama studija aktivno je studiralo 1946 studenata, a svoj studij u tom razdoblju uspješno su završila 164 magistra inženjera, 227 sveučilišnih prvostupnika i 79 stručnih prvostupnika. U istoj je akademskoj godini na našem Fakultetu sedmero kandidata obranilo doktorsku disertaciju.

Unapređivanje uvjeta rada u nastavnim i laboratorijskim prostorima stalna je odrednica djelovanja Fakulteta, te u skladu sa svojim mogućnostima Fakultet neprekidno ulaže u podizanje kvalitete ovih bitnih resursa. U akademskoj godini 2019./2020. uloženo je oko tri milijuna kuna u nabavku nove laboratorijske opreme i razvoj računalne infrastrukture te održavanje prostora Fakulteta.

Kao i prethodnih godina, Fakultet je tijekom ak. god. 2019./2020. uložio više od dva milijuna kuna u nabavku opreme s ciljem osuvremenjavanja i unaprjeđenja nastavnih aktivnosti.

Nastava je u ljetnom semestru ak. god. 2019./2020., zbog izvanrednih okolnosti uzrokovanih pandemijom korona virusa, počevši od 16. ožujka, u potpunosti, uključujući i provjere ishoda učenja tijekom nastave te obrane završnih i diplomskih radova, održana na daljinu korištenjem platformi za udaljena predavanja. Međutim, svi su ispiti u ispitnim rokovima nakon ljetnog semestra i u jesenskom ispitnom roku održani na Fakultetu uz strogo pridržavanje svih propisanih epidemioloških mjera, čime je osigurana kvaliteta vrednovanja i ocjenjivanja stečenih ishoda učenja.

Tijekom travnja, svibnja i lipnja 2020. godine po drugi puta su u organizaciji Fakulteta održane pripreme za ispit iz A razine matematike na državnoj maturi za maturante kojima su studiji Tehničkog fakulteta bili prvi ili drugi izbor. Pripreme u trajanju od 40 nastavnih sati održali su nastavnici Fakulteta u virtualnom okruženju korištenjem platforme za udaljeni pristup.

Uvodno predavanje za studente prvih godina preddiplomskih sveučilišnih studija, na kojem su studentima koji započinju studij dane osnovne informacije o studijima i studiranju, održano je na daljinu krajem rujna 2020. godine. Na Fakultetu su u istome tjednu u manjim grupama, pridržavajući se propisanih epidemioloških mjera,

In the 2019/2020 academic year 1946 students studied actively at the Faculty of Engineering, of whom 164 earned the master's degree, 227 the university bachelor's degree and 79 the vocational bachelor's degree. In the same year, seven candidates defended their doctoral thesis at our Faculty.

The improvement of the working conditions in teaching and laboratory premises is a permanent concern of the Faculty, and in line with its possibilities the Faculty continuously invests in the improvement of the quality of these important resources. In the 2019/2020 academic year, around three million kunas was invested in the purchase of new laboratory equipment, the development of computer infrastructure and the maintenance of the Faculty premises.

As in previous years, the Faculty during the 2019/2020 academic year invested more than two million kunas in the procurement of equipment with the aim of modernising and improving teaching activities.

In the summer semester of the 2019/2020 academic year, due to extraordinary circumstances caused by the coronavirus pandemic, starting from 16 March, classes were completely held online using different platforms for distant learning. Assessment as well as defenses of final and graduate theses were also held online. However, all exams in the summer and autumn exam sessions were held at the Faculty with strict adherence to all prescribed epidemiological measures, thus ensuring the quality of evaluation and assessment of acquired learning outcomes.

During April, May and June 2020, for the second time, the Faculty organised preparations for the exam in the A level of mathematics at the national school-leaving examinations for all the graduates who opted for studies at the Faculty of Engineering as their first or second choice. Preparations lasting 40 teaching hours were held by Faculty teachers in a virtual environment using a remote access platform.

At the end of September 2020, an introductory lecture for first-year undergraduate university students, in which students starting their studies were given basic information about their studies,

was held online. In the same week, introductory meetings of new students with study coordinators were held at the Faculty in small groups, adhering to the prescribed epidemiological measures.

Prije početka nastave u novoj ak. god., u zadnjem tjednu rujna, kao i prethodnih godina, održani su pripremni seminari za nove studente iz matematike i programiranja, s ciljem ponavljanja određenih sadržaja i pripreme studenata za studij. Pripremni su seminari u 2020. godini održani na daljinu u online okruženju.

Tijekom akademske godine 2019./2020. na Tehničkom fakultetu su se odvijale brojne istraživačke aktivnosti, većinom u okviru rada na 40 znanstvenih projekata, od čega 5 znanstvenih projekata Hrvatske zaklade za znanost, 7 EU projekata, 27 projekata financiranih od strane Sveučilišta u Rijeci, 2 bilateralna projekta i 2 istraživačka projekta s gospodarstvom. Obzirom na bogatu istraživačku aktivnost, rezultati istraživanja znanstvenika diseminirani su prilikom sudjelovanja na brojnim konferencijama te kroz objavu radova u časopisima od kojih je veliki broj klasificiran u najvišoj kategoriji. Kako bi se povećala vidljivost znanstvenih aktivnosti, događaja vezanih uz znanost, doktorskih studija i samih značajnih znanstvenih postignuća, osvježena je web stranica za znanost koja ističe napore znanstvenika i napredak znanosti na fakultetu. Tako se posebna pažnja pridaje doktorskim studijima, publikacijama i konferencijama, istraživanju i projektima, laboratorijskim i opremi te programima, natječajima i događanjima. Na fakultetu se vratila i već tradicionalna konferencija za doktorande 4th My First Conference koja je pokazala visoku kvalitetu, svestranost i interdisciplinarnost u istraživanjima doktoranada Tehničkog fakulteta.

Tijekom akademske godine 2019./2020., Tehnički fakultet nastavlja s realizacijom mobilnosti studenata i profesora u sklopu Erasmus+ programa na način da je studentima omogućena mobilnost u svrhu studijskog boravka i obavljanja stručne prakse dok se mobilnost nastavnog i nenastavnog osoblja ostvaruje u svrhu održavanja nastave i/ili stručnog usavršavanja.

Tehnički fakultet trenutno ima sklopljenih 27 Erasmus+ bilateralnih ugovora sa Sveučilištima iz Austrije, Cipra, Češke, Finske, Francuske, Italije, Litve, Mađarske, Poljske, Portugala, Rumunjske, Slovenije, Srbije i Švedske.

Tijekom akademske godine 2019./2020., putem programa Erasmus+ mobilnosti, studenti Tehničkog fakulteta ostvarili su osam studijskih mobilnosti te dvije mobilnosti u svrhu obavljanje stručne prakse. Istovremeno smo ugostili devetero dolaznih stranih studenata. Jedan profesor Tehničkog fakulteta realizirao je odlaznu mobilnost u svrhu usavršavanja, a na Tehničkom fakultetu boravio je jedan profesora sa svrhom održavanja nastave te jedan na usavršavanju.

Suradnja s gospodarstvom kao i s drugim znan-

was held online. In the same week, introductory meetings of new students with study coordinators were held at the Faculty in small groups, adhering to the prescribed epidemiological measures.

In the last week of September, before the start of classes in the new academic year, as in previous years, preparatory seminars were held for new students in mathematics and programming, with the aim of revising certain contents and preparing students for study. Preparatory seminars in 2020 were held remotely in an online environment.

Numerous research activities took place at the Faculty of Engineering during the academic year 2019/2020., mostly within the framework of 40 scientific projects, of which 5 scientific projects are funded by Croatian Science Foundation, through 7 EU projects, by 27 projects funded by the University of Rijeka, 2 bilateral projects and 2 research projects with economy. Due to the rich research activity, the research results of scientists were disseminated when participating in numerous conferences and through the publication of journals, many of which are classified in the highest category. In order to increase the visibility of scientific activities, science-related events, doctoral studies and the most significant scientific achievements themselves, a science website has been updated that highlights the efforts of scientists and the advances in science. Thus, special attention is paid to doctoral studies, publications and conferences, research and projects, laboratories and equipment, as well as programs, competitions and events. The already traditional 4th My First Conference for doctoral students has again been organised at the Faculty, which has shown high quality, versatility and interdisciplinarity in the research of doctoral students at the Faculty of Engineering.

During the 2018/2019 academic year, the Faculty of Engineering continued the realisation of the mobility of students and professors within the framework of the Erasmus+ programme, so that mobility is provided to students in order to study and complete professional practice, while mobility of the teaching and non-teaching staff is provided for the purpose of teaching, that is professional development.

The Faculty of Engineering currently has 27 Erasmus+ bilateral agreements with universities from Austria, Cyprus, the Czech Republic, Finland, France, Italy, Lithuania, Hungary, Poland, Portugal, Romania, Slovenia, Serbia and Sweden.

In the 2019/2020 academic year, eight of our students used the study mobility programme and two used it for professional practice, while at the same time we welcomed nine foreign students. One of our teachers used the mobility

stvenim i obrazovnim ustanovama iznimno je bitan segment djelatnosti Fakulteta. Stoga je i u akademskoj godini 2019./2020. nastavljeno s umrežavanjem i poticanjem zajedničkog rada na znanstvenim i stručnim projektima, a sklopljeno je i više ugovora i sporazuma o znanstvenoistraživačkoj, obrazovnoj i stručnoj suradnji.

for professional development, while we hosted one foreign teacher who used the mobility to hold lectures and one for his professional development.

The collaboration with the economy as well as with other scientific and educational institutions is an extremely important domain of the Faculty's activities. Therefore, in the 2019/2020 academic year, the Faculty continued with the networking and encouragement of cooperation on scientific and professional projects, and several contracts and agreements on scientific-research, educational and professional cooperation were concluded.



## 2.2 studenti nagrađeni u ak. godini 2019./2020. awarded students in the 2019/2020 academic year

### nagrada za akademski uspjeh | award for academic achievements

#### PREDDIPLOMSKI SVEUČILIŠNI STUDIJ | UNDERGRADUATE UNIVERSITY STUDY

Studij / Study	Godina / Year	Ime i prezime / Name and surname	Postotak uspješnosti / Success rate		ECTS
			godine / year	studija / study	
Strojarstvo/ Mechanical Engineering	1.	Marino Odorčić	83%	83%	60
	2.	Leona Petrc	91%	90%	120
Elektrotehnika/ Electrical Engineering	1.	Mateo Malvić	91%	91%	60
	2.	Dean Krbavac	95%	96%	120
Računarstvo/ Computing	1.	Darijan Jelušić	94%	94%	60
	2.	Lucija Žužić	97%	98%	120

#### SVEUČILIŠNI PRVOSTUPNICI INŽENJERI | UNIVERSITY BACHELOR ENGINEERS

Studij / Study	Ime i prezime / Name and surname	Postotak uspješnosti / Success rate
Strojarstvo/ Mechanical Engineering	Sanja Bjelobradić	89%
Brodogradnja/ Naval architecture	Dora Vojnić	80%
Elektrotehnika/ Electrical Engineering	Tajana Cvija	90%
Računarstvo/ Computing	Marina Banov	93%

#### DIPLOMSKI SVEUČILIŠNI STUDIJ | GRADUATE UNIVERSITY STUDY

Studij / Study	Godina / Year	Ime i prezime / Name and surname	Postotak uspješnosti / Success rate		ECTS
			godine / year	studija / study	
Strojarstvo/ Mechanical Engineering	1.	Lovre Šušić	97%	97%	60
Brodogradnja/ Naval architecture	1.	Petar Lisičić	93%	93%	60
Elektrotehnika/ Electrical Engineering	1.	Mateo Požgaj	93%	93%	60
Računarstvo/ Computing	1.	Mateja Napravnik	98%	98%	60

### MAGISTRI INŽENJERI | MASTER ENGINEERS

Studij / Study	Ime i prezime / Name and surname	Postotak uspješnosti / Success rate
Strojarstvo/ Mechanical Engineering	Marta Alvir	91%
Brodogradnja/ Naval Architecture	Srđan Pletikapa	82%
Elektrotehnika/ Electrical Engineering	Petra Kokotović	93%
Računarstvo/ Computing	Marko Njirjak	96%

### STRUČNI PRVOSTUPNICI INŽENJERI | BACHELOR ENGINEERS

Studij / Study	Ime i prezime / Name and surname	Postotak uspješnosti / Success rate
Strojarstvo/ Mechanical Engineering	Antonio Martinović	83%

### nagrada dekana za studentski aktivizam | dean's award for student activism

#### MATEO BERKOVIĆ

- Student 2. godine diplomskog sveučilišnog studija strojarstva  
/ Student of the 2nd year of Graduate University Study of Mechanical Engineering

#### VITO MEDVED

- Student 2. godine diplomskog sveučilišnog studija računarstva  
/ Student of the 2nd year of Graduate University Study of Computing



## 2.3 časopis "engineering review" the journal "engineering review"



Tehnički fakultet Sveučilišta u Rijeci ima dugu tradiciju izdavanja znanstvenih radova. Publiciranje znanstvenih radova djelatnika Tehničkog fakulteta seže u 1970. godinu kada započinje tiskanje Zbornika radova. Godine 1988. spomenuta edicija mijenja naziv u Zbornik Tehničkog fakulteta Rijeka, a 1995. godine uspostavlja se naziv Engineering Review, pod kojim se časopis i danas tiska.

Sve spomenute edicije bile su na raspolaganju za objavu radova kako nastavnog osoblja samog Fakulteta, tako i svima zainteresiranima. Fakultet nastoji zainteresirati znanstvenu javnost za publiciranje znanstvenih radova radi širenja razmjene znanstvenih postignuća temeljenih na istraživačkom radu. Područja iz kojih se u časopisu mogu objavljivati radovi prvenstveno obuhvaćaju strojarstvo, brodogradnju, temeljne tehničke znanosti, elektrotehniku, računalne znanosti i građevinarstvo. U ovom smislu časopis predstavlja jedan od rijetkih medija za publiciranje radova iz vrlo širokog dijapazona tehničkog područja. Razmatraju se i radovi koji su kvalitetni, a nisu izravno iz tehničkog područja, već mogu biti, primjerice, iz prirodnih znanosti, s određenom poveznicom s područjem tehnike. Nakon potpisanog ugovora o suizdavaštvu časopisa Engineering Review između Tehničkog fakulteta Sveučilišta u Rijeci i Građevinskog fakulteta Sveučilišta u Rijeci (2011. g.), nastavljaju se aktivnosti oko izdavanja.

Izdavanje časopisa Engineering Review, od druge polovice 2011. godine, nastavlja se pod vodstvom glavnog urednika prof. dr. sc. Josipa Brnića, profesora emeritusa (Editor-in-Chief). Pomoćni urednici (Associate Editors) su: prof. dr. sc. Marina Franulović, prof., dr. sc. Kristian Lenić, prof., dr. sc. Aleksandra Deluka-Tibljaš, prof., dr. sc. Domagoj Lanc, prof., dr. sc. Dubravko Franković, prof., dr. sc. Jonatan Lerga, prof., dr. sc. Dario Iljčić, prof. Rad je prihvaćen za objavu u časopisu nakon dviju pozitivnih recenzija i obavljene jezične lekture. Jezičnu lekturu svih radova, nakon njihovih pozitivnih recenzija, uspješno obavlja Alenka Šunjić-Petric,

The Faculty of Engineering of the University of Rijeka has a long tradition of publishing scientific papers. Significantly, the publication of scientific papers by the employees of the Faculty of Engineering dates back to 1970, when the first issue of Proceedings was published. In 1988, this edition was renamed the Proceedings of the Rijeka Faculty of Engineering and finally in 1995, the journal was renamed again into Engineering Review, its present title.

All these editions have readily published papers written not only by the teaching staff of the Faculty but also by all other interested authors. The Faculty makes every effort to arouse interest of the scientific community in the publication of scientific papers, all with the aim of disseminating and sharing scientific achievements based on research work. Papers eligible for publication in the journal are primarily those from the field of mechanical engineering, naval architecture, fundamental engineering sciences, electrical engineering, computer engineering and civil engineering. In this sense, the journal is one of the few bases that publish papers covering a wide range of engineering areas. However, quality papers not directly from the engineering area are also taken into consideration, for instance, those from the field of natural sciences but linked in a way to the area of engineering. The Faculty of Engineering of Rijeka University and the Faculty of Civil Engineering of Rijeka University entered into a Contract on co-edition (2011) of Engineering Review, thus ensuring the continuation of its publication.

As of the second half of 2011, Engineering Review has been published under the guidance of Editor-in-Chief, Prof. D. Sc. Josip Brnić, Professor emeritus. The Associate Editors are: Prof. D. Sc. Marina Franulović, Prof. D. Sc. Kristian Lenić, Prof. D. Sc. Aleksandra Deluka-Tibljaš, Prof. D. Sc. Domagoj Lanc, Prof. D. Sc. Dubravko Franković, Prof. D. Sc. Jonatan Lerga and Prof. D. Sc. Dario Iljčić. A paper is accepted for publication in the journal after two positive reviews, after which language editing of

Ph. D. Računalnu podršku i rješenja pruža Tatjana Škorjanc, dipl. ing. Broj članova Editorial Boarda kao i broj članova Advisory Editorial Boarda, proširen je. Članovi obaju uredništva su eminentni domaći i inozemni profesori i stručnjaci. Veliku pomoć u pripremi, uređivanju i tiskanju radova pružaju nastavnici, asistenti i znanstveni novaci Tehničkog fakulteta: doc. dr. sc. Boris Delač, doc. dr. sc. Ivan Volarić, doc. dr. sc. Kristina Marković, assist. Fran Torbarina, te dr. sc. Ivica Androjić i assist. Ivana Pranjić s Građevinskog fakulteta u Rijeci.

Časopis Engineering Review indeksiran je u: Aluminum Industry Abstracts, Advanced Polymers Abstracts, Cambridge Scientific Abstract (CSA), Ceramic Abstracts/World Ceramics Abstracts, Composites Industry Abstracts, Computer and Information Systems Abstracts, Copper Technical Reference Library, Corrosion Abstracts, Electronics and Communications Abstracts, Engineered Materials Abstracts, High Technology Research Database with Aerospace, Inspec, Mechanical & Transportation Engineering Abstracts, METADEX, SCImago, SCOPUS, Web of Science (Emerging Sources Citation Index, od 2015. god.).

Temeljem SCIMAGO kategorizacije rangiranja časopisa, u 2019. godini svrstan je u Q2 (druga kvartila). Časopis je uređen za elektroničku obradu svih podataka i elektroničku komunikaciju, od prijave radova do recenzentskih postupaka i priopćavanja rezultata podnositeljima (autorima) radova. Ima široku bazu domaćih i inozemnih recenzenta koja se stalno dopunjava. Svaki rad recenziraju najmanje dva recenzenta od kojih je najmanje jedan inozemni. Za prihvaćanje rada niti jedna recenzija ne smije biti negativna. Časopis se objavljuje na engleskom jeziku, tri broja godišnje, a radovi su dostupni online (Hrčak, Tehnički fakultet u Rijeci) i u tiskanom obliku. Časopis također može objaviti određeni broj kvalitetnih radova s kongresa, a njihova kvaliteta mora biti zagarantirana jednom recenzijom kongresa i jednom novom recenzijom. Spomenuti radovi idu u prijavu istom procedurom kao i svi drugi radovi. Na kraju valja spomenuti kako je zainteresiranost za publiciranjem radova u časopisu velika, a ponude za objavljivanjem dolaze iz inozemstva i iz Hrvatske. Ovakvoj zainteresiranosti svakako doprinosi uređeni sustav prijave, recenzija, indeksiranost i komunikacija s autorima.

all papers is successfully carried out by D. Sc. Alenka Šunjić-Petric. Assistance with computer solutions has been provided by Tatjana Škorjanc, B. Sc. Furthermore, the member lists of both Editorial Board and Advisory Editorial Board have increased and now include prominent domestic and foreign professors and experts. A great assistance in the preparation and publication of papers is received by teachers, assistants and junior researchers of the Faculty of Engineering: Assist. Prof. Boris Delač, D. Sc., Assist. Prof. Ivan Volarić, D. Sc., Assist. Prof. Kristina Marković, D. Sc., Assist. Fran Torbarina, as well as D. Sc. Ivica Androjić and Assist. Ivana Pranjić from the Faculty of Civil Engineering in Rijeka.

Engineering Review has the following indexing: Aluminum Industry Abstracts, Advanced Polymers Abstracts, Cambridge Scientific Abstract (CSA), Ceramic Abstracts/World Ceramics Abstracts, Composites Industry Abstracts, Computer and Information Systems Abstracts, Copper Technical Reference Library, Corrosion Abstracts, Electronics and Communications Abstracts, Engineered Materials Abstracts, High Technology Research Database with Aerospace, Inspec, Mechanical & Transportation Engineering Abstracts, METADEX, SCImago, SCOPUS, Web of Science (Emerging Sources Citation Index, from 2015).

According to the SCImago categorization of the journals for 2019 year, Engineering Review was included in Q2 (second quartile). The journal uses electronic processing of all data, so that information on paper application, review procedures and results are electronically communicated to the authors. The journal has a broad base of national and international reviewers, which is constantly being supplemented. Each paper is reviewed by at least two referees, one of whom must be foreign. For the acceptance of the paper, all reviews have to be positive. The journal is published in English, in three issues annually, and the papers are available online (Hrčak, Faculty of Engineering Rijeka) and in printed form. The journal can also include a certain number of quality papers from a congress provided that their quality is guaranteed by one review of the congress and another new review. These papers undergo the same application procedure as all other papers. Finally, it is worth mentioning that lots of authors from Croatia and abroad have shown their interest in publishing their scientific papers in Engineering Review. Communication with authors, an ordered system of application, review and indexing highly contribute to the importance of the journal.

## 2.4 alumni tfr alumni tfr



Alumni klub Tehničkog fakulteta Sveučilišta u Rijeci, skraćena naziva ALUMNI TFR, udruga je osnovana s primarnim ciljem uspostave i jačanja veza i suradnje između bivših studenata Tehničkoga fakulteta, ali i između bivših studenata međusobno. Udruga je osnovana pod nazivom Akademski klub doktora znanosti, magistara znanosti, diplomiranih inženjera i inženjera Tehničkoga fakulteta Sveučilišta u Rijeci na Osnivačkoj skupštini održanoj u Mramornoj dvorani Pomorskoga i povijesnoga muzeja Hrvatskoga primorja i Rijeke, dana 24. studenoga 2000. godine, u sklopu obilježavanja 40 godina djelovanja Fakulteta.

Svrha ALUMNI TFR je očuvanje tradicije Tehničkoga fakulteta Sveučilišta u Rijeci, promicanje ugleda Fakulteta u Republici Hrvatskoj i inozemstvu, skrb za razvitak i napredak Fakulteta, njegovanje i razvitak etike inženjerskoga poziva, utjecaj na stvaranje javnoga znanstvenog i stručnog mišljenja o svim bitnim pitanjima razvoja struke i znanosti te njihove primjene, utjecaj na razvitak i napredak spoznaje o potrebi očuvanja prirode i čovjekova okoliša, izgradnja i jačanje veza i suradnje između bivših studenata i Fakulteta, poticanje i uspostava veza i suradnje Fakulteta i sličnih obrazovnih, razvojnih i istraživačkih institucija u Republici Hrvatskoj i u svijetu, promicanje ugleda inženjerske struke te uspostava i razvijanje suradnje sa sličnim udrugama kod nas i u svijetu.

Predsjednik ALUMNI TFR je doc. dr. sc. Vedran Kirinčić, dipl. ing., potpredsjednici su: doc. dr. sc.

The Alumni Club of the Faculty of Engineering, Rijeka University (ALUMNI TFR) is an association established with the primary aim of fostering and strengthening liaisons and cooperation between the former alumni and the Faculty and among the alumni themselves. The association, founded under the name of Academic Fellowship, comprises holders of PhD, master's and bachelor's degrees (including former graduate and vocational engineers) of the Faculty of Engineering of the University of Rijeka. It was established at the Inaugural Meeting held in the Marble Hall of the Maritime and History Museum of Croatian Littoral Rijeka on 24 November 2000 to mark the 40th anniversary of the Faculty.

The purpose of the ALUMNI TFR is to preserve the tradition of higher education at the Faculty of Engineering of Rijeka University, to promote the reputation of the Faculty in the Republic of Croatia and abroad, to care for its development and progress, to nurture and foster ethics in the engineering profession, to exert influence on the creation of public scientific and professional opinion about all important issues in the development of profession and science, and on the development and advancement of awareness about the need to preserve the nature and the environment. Moreover, the aim is also to strengthen relations and cooperation between the former alumni and the Faculty, to encourage the establishment of links and cooperation between the Faculty and similar educational, developmental and research institutions in



Jonatan Lerga, dipl. ing. i Danko Venturini, dipl. ing., a tajnik je doc. dr. sc. Rene Prenc, dipl. ing. U predsjedništvu su: izv. prof. dr. sc. Robert Basan dipl. ing., prof. dr. sc. Bernard Franković, dipl. ing., doc. dr. sc. Vladimir Glažar, dipl. ing., doc. dr. sc. Vedran Kirinčić, dipl. ing., dr. sc. Serđo Klapčić, dipl. ing., prof. dr. sc. Božidar Križan, dipl. ing., doc. dr. sc. Jonatan Lerga, dipl. ing., Ante Maras, dipl. ing., Mladen Merlak, dipl. ing., prof. dr. sc. Zoran Mrša, dipl. ing., prof. dr. sc. Duško Pavletić, dipl. ing., ujedno i dekan Tehničkoga fakulteta, prof. dr. sc. Zmagoslav Prelec, dipl. ing., prof. dr. sc. Jasna Prpić-Oršić, dipl. ing., Siniša Reljić, dipl. ing. i Danko Venturini, dipl. ing. Likvidatorom je imenovan prof. dr. sc. Vladimir Medica, dipl. ing. Nadzorni odbor čine: mr. sc. Slavko Štambuk, dipl. ing., dr. sc. Aleksandar Regent, dipl. ing. i Davor Mihovilić, dipl. ing.

U organizaciji ALUMNI TFR, tijekom ak. god. 2019./2020., realizirane su sljedeće aktivnosti:

- 02.12.2019. g. u suorganizaciji s IEEE Studentskim ogranakom i Studentskim Zborom Tehničkoga fakulteta Sveučilišta u Rijeci održano je predavanje Damira Medveda iz tvrtke "Ericsson Nikola Tesla", na temu "Robotizacija kontejnerskih luka"  
02.12.2019 in cooperation with the IEEE Student branch and the Student council of the Faculty of Engineering, University of Rijeka, Damir Medved, from the company Ericsson Nikola Tesla held the lecture: „Robotization of container ports“
- Tijekom rujna i listopada 2019. g. prof. dr. sc. Zoran Mrša, dipl. ing. je organizirao proslavu jubilarnih godišnjica upisa generacija fakulteta (5., 10., 15., 20., 25. i 30. generacija studenata)  
During September and October 2019, Prof. D. Sc. Zoran Mrša, M.Eng. organized the celebration of jubilee anniversaries of the enrollment of generations at the Faculty (5th, 10th, 15th, 20th, 25th and 30th generation of students)
- 26.11.2019. g. održan je sastanak Predsjedništva Alumni kluba Tehničkoga fakulteta u Rijeci  
On 26.11.2019 the meeting of Presidency of ALUMNI TFR took place.

Croatia and worldwide, to promote the reputation of the engineering profession and establish and develop cooperation with similar organizations at home and abroad.

The ALUMNI TFR board is comprised of: Assis. Prof. D.Sc. Vedran Kirinčić, M.Eng., chairman, vice chairmen Assis. Prof. D. Sc. Jonatan Lerga, M.Eng. and Danko Venturini, M.Eng., including secretary Assis. Prof. D. Sc. Rene Prenc, M.Eng. The current members include:

Assoc. Prof. D. Sc. Robert Basan, M.Eng., Prof. D. Sc. Bernard Franković, M.Eng., Assis. Prof. D. Sc. Vladimir Glažar, M.Eng., Assis. Prof. D. Sc. Vedran Kirinčić, M.Eng., D. Sc. Serđo Klapčić, M.Eng., Prof. D. Sc. Božidar Križan, M.Eng., Assis. Prof. D. Sc. Jonatan Lerga, M.Eng., Ante Maras, M.Eng., Mladen Merlak, M.Eng., Prof. D. Sc. Zoran Mrša, M.Eng., Prof. D. Sc. Duško Pavletić, M.Eng. and Dean of the Faculty of Engineering, Prof. D. Sc. Zmagoslav Prelec, M.Eng., Prof. D. Sc. Jasna Prpić-Oršić, M.Eng., Siniša Reljić, M.Eng. and Danko Venturini, M.Eng., including Prof. D. Sc. Vladimir Medica, M.Eng. as liquidator. The current members of the Supervisory Board are: M.Sc. Slavko Štambuk, M.Eng., D. Sc. Aleksandar Regent, M.Eng. and Davor Mihovilić, M.Eng.

During the 2019/2020 academic year, the following activities were realized by the ALUMNI TFR:



## 2.5 doktorske disertacije obranjene u akademskoj godini 2019./2020. doctoral dissertations defended in academic year 2019/2020



**IME I PREZIME | NAME AND SURNAME:**  
Tihana Kostadin

**POLJE | SCIENTIFIC FIELD:**  
Strojarstvo / Mechanical Engineering

**NAZIV RADA | TITLE:**  
Utjecaj hlađenja hladnim komprimiranim zrakom na korozijsku otpornost pri obradi dijelova od nehrđajućeg čelika  
Effect of cooling with cold compressed air on the corrosion resistance of machined parts made of stainless steel

**MENTOR | SUPERVISOR:**  
prof. dr. sc. / Prof. D. Sc. Goran Cukor

**DATUM OBRANE | DATE OF DEFENCE:**  
18.10.2019.

Sažetak:

Kod strojne obrade nehrđajućih čelika rezanjem se redovito preporučuje uporaba specijalnih tekućina za hlađenje i podmazivanje s visokim protokom. Međutim, konvencionalne tekućine na osnovi mineralnih ulja imaju negativni učinak na okoliš, zdravlje radnika i troškove proizvodnje. Alternativna tehnika hlađenja ohlađenim komprimiranim zrakom uporabom Ranque-Hilschove vrtložne cijevi protusmjernog protoka u obradi martenzitnog nehrđajućeg čelika X20Cr13 postupkom

Summary:

It is recommended that cutting fluids with high flow rate are used when stainless steels are machined. However, conventional mineral oil-based cutting fluids have a negative impact on the environment, workers' health and production costs. Alternative cooling technique with cooled compressed air using the Ranque-Hilsch's counter-flow vortex tube in machining of martensitic stainless steel X20Cr13 by turning is the subject of this research. The aim was to determine the effect

tokarenja je predmet ovog istraživanja. Cilj je bio utvrditi utjecaj takvog hlađenja na korozijsku otpornost obrađene površine i njegovu tehnološku i ekonomsku održivost u usporedbi s konvencionalnim hlađenjem emulzijom u svrhu postizanja ekološki prihvatljive obrade. Zrak kao rashladni medij je potpuno prirodan pa je ova tehnika hlađenja najčišća i ekološki najprihvatljivija. Budući da se korozija može pojaviti i u suhoj obradi, korozijska otpornost je određena elektrokemijskim i gravimetrijskim mjerenjima. Kemijski sastav i izgled površine prije i nakon ispitivanja korozijske otpornosti je utvrđen pretražnom elektronskom mikroskopijom u kombinaciji s energijski razlučujućom rendgenskom spektroskopijom. Od osobitog je značaja otkriće da se obrađena površina ispitnog materijala tokarenog uz hlađenje vrtložnom cijevi dugoročno bolje odupire korozijskom djelovanju od one dobivene tokarenjem uz hlađenje emulzijom. Također, potvrđeno je da minimalna hrapavost obrađene površine osigurava maksimalnu korozijsku otpornost. Analiza uloge hrapavosti obrađene površine u koroziji nehrđajućih čelika je osobito zanimljiva jer je to parametar koji se može pratiti još u procesu obrade što je usvojeno u ovom istraživanju. Analizom varijance eksperimentalnih rezultata dobivenih ispitivanjem obradivosti prema okretljivom centralno kompozitnom planu pokusa je utvrđeno da različite tehnike hlađenja (emulzijom odnosno vrtložnom cijevi) ne utječu značajno na hrapavost obrađene površine ispitnog materijala i time na korozijsku otpornost. Izvornim proračunom jediničnog proizvodnog troška je dokazano da hlađenje vrtložnom cijevi nudi ekonomično rješenje na putu prema održivoj obradi. Zaključuje se da hlađenje ohlađenim komprimiranim zrakom uporabom vrtložne cijevi pozitivno utječe na sva tri segmenta održivog razvoja – ekološki, sociološki i ekonomski pa se za tokarenje martenzitnog nehrđajućeg čelika X20Cr13 umjesto hlađenja emulzijom preporučuje ova tehnika hlađenja.

of such cooling on the corrosion resistance of the machined surface and its technological and economic viability compared to conventional emulsion cooling for the purpose of achieving ecologically acceptable machining. The air as a cooling medium is completely natural so this cooling technique is the cleanest and most environmentally acceptable one. Since corrosion can also occur in dry machining, corrosion resistance was determined by electrochemical and gravimetric measurements. The chemical composition and appearance of the surface before and after the corrosion resistance test was determined by scanning electron microscopy in combination with energy dispersive X-ray spectroscopy. Particularly important is the discovery that the surface of the test material machined by the turning operation with cooling by means of the vortex tube is more resistant to corrosion than that obtained by the turning operation with cooling by means of the emulsion. Also, it has been confirmed that the machined surface minimum roughness ensures maximum corrosion resistance. The role analysis of the machined surface minimum roughness in the corrosion of stainless steel is particularly interesting as this parameter can be traced yet in the machining process, and this is adopted in this research. By the analysis of variance of the experimental results obtained by the machinability testing according to the rotatable central composite design of the experiments, it was found that various cooling techniques (emulsion or vortex tube) did not significantly influence the machined surface roughness of test material, and hence the corrosion resistance. By the original calculation of the unit production cost, it has been proved that the cooling with the vortex tube offers an economical solution on the route to sustainable machining. It is concluded that the cooling with cooled compressed air using the vortex tube positively affects all three segments of sustainable development – ecologic, sociologic and economic, so for the turning of martensitic stainless steel X20Cr13, instead of conventional cooling by emulsion, the cooling with the vortex tube is recommended.

**IME I PREZIME | NAME AND SURNAME:**

Vedrana Špada

**POLJE | SCIENTIFIC FIELD:**

Strojarstvo / Mechanical Engineering

**NAZIV RADA | TITLE:**

Priprava nanokompozita iz ugljikovih nanocijevi i Al-legure visokotlačnim lijevanjem

Preparation of nanocomposites from carbon nanotubes and Al-alloy by high pressure die casting

**MENTORI | SUPERVISORS:**

doc. dr. sc. / Assist. Prof. D. Sc. Dario Ijkić

izv. prof. dr. sc. / Assoc. Prof. D. Sc. Ivan Brnardić

**DATUM OBRANE | DATE OF DEFENCE:**

13.12.2019.

**Sažetak:**

Radi sve strožih ekoloških zahtjeva s kojima se suočava automobilska industrija potrebno je suvremena istraživanja usmjeriti prema, osim inovacijama u izradi motora, poboljšavanju goriva te sagorijevanju, razvoju novih konstrukcijskih materijala manje mase s ciljanim mehaničkim svojstvima za primjenu u automobilu. Za svrhu izrade „lakših“ autodijelova sve se više koriste kompozitni i nanokompozitni materijali. Ukoliko se pripremom kompozita i nanokompozita dobiju materijali boljih mehaničkih svojstava, automobilski dio može se proizvesti tanji, što u konačnici dovodi do smanjenja mase automobila te potrošnje goriva, kao i emisije ugljikovog (IV) oksida (CO<sub>2</sub>) u atmosferu. U literaturi su zastupljena istraživanja pripreme nanokompozitnih materijala s polimernom matricom za primjenu u automobilskoj industriji, dok za nanokompozite s metalnom matricom ima relativno malen broj istraživanja, a za postupak visokotlačnog lijevanja (engl. High Pressure Die Casting, HPDC) gotovo uopće nema podataka. U ovom radu pripremljeni su nanokompozitni materijali na bazi aluminijeve legure AlSi9Cu3(Fe) i višestijenih ugljikovih nanocijevi (engl. Multi-Walled Carbon Nanotubes, MWCNT) kao ojačala postupkom visokotlačnog lijevanja. 0,05, 0,1 i 0,2 mas.% ojačala dodavano je u taljevinu na dvije različite pozicije unutar jedinice za visokotlačno lijevanje, u komoru prije klipa i na početak alata te se u jednom eksperimentu matrica mijenjala dodavanjem legirajućeg elementa magnezija uz dodavanje ojačala miješanjem u taljevinu. Ispitan je kemijski sastav matrice optičkim emisijskim spektrometrom, istražena je distribucija i toplinska stabilnost ojačala u matrici kao i njihov utjecaj na mikrostrukturu svjetlosnom mikroskopijom i elektronskom mikroskopijom s energetsom disperzijom, provedena su mehanička ispitivanja na univerzalnoj statičkoj

**Summary:**

Due to the increasingly stringent environmental requirements facing the automotive industry, modern research needs to be directed toward, apart from innovations in engine design, fuel improvement and combustion, the development of new low-mass structural elements with targeted mechanical properties for in-car applications. Composite and nanocomposite materials are increasingly being used for the purpose of making „lighter“ auto parts. If materials of better mechanical properties are obtained by the preparation of composites and nanocomposites, the car part can be produced thinner or lighter, which ultimately leads to a reduction in car mass and fuel consumption, as well as the emission of carbon (IV) oxide (CO<sub>2</sub>) into the atmosphere. Research on the preparation of nanocomposites with a polymer matrix for use in the automotive industry have been reported in the literature, while relatively few studies are available for metal-matrix nanocomposites and almost no data is available for the High Pressure Die Casting (HPDC) process of nanocomposite preparation. In this doctoral thesis, nanocomposite materials based on AlSi9Cu3 (Fe) Aluminium alloy and Multi-Walled Carbon Nanotubes (MWCNTs) were prepared by High Pressure Die Casting. The 0.05, 0.1 and 0.2 mas.% of nanofillers were added to the melt at two different positions within the high-pressure casting unit, in the pre-piston chamber and at the beginning of the tool, and in one experiment the matrix was changed by adding a Magnesium alloying element with adding nanofillers by mixing them in the melt. The chemical composition of the matrix was investigated with an optical emission spectrometer, the distribution and thermal stability of the nanofillers in the matrix after HPDC were investigated, as well as their influence on the microstructure by light microscopy and electron microscopy

kidalici i određena je tvrdoća prema Vickersu. U svim nanokompozitima materijalima nije došlo do toplinske degradacije ojačala, a najbolja homogenost je postignuta kod uzoraka s 0,05% ojačala uz magnezij. Novi materijali dobiveni dodavanjem ojačala u komoru su pokazali bolja mehanička svojstva (povećanje vlačne čvrstoće za 16,5 % i istezljivosti za 49,7 %) u odnosu na čistu leguru.

with energy dispersion, mechanical tests were carried out on a universal testing machine and Vickers hardness was determined. In all nanocomposite materials thermal degradation of the nanofillers did not occur, and the best homogeneity was achieved in the samples with 0.05% MWCNT and Magnesium. The new materials obtained by adding nanofillers to the chamber showed better mechanical properties (increase in tensile strength of 16.5% and ductility of 49.7%) over pure alloy.

**IME I PREZIME | NAME AND SURNAME:**

Marko Perčić

**POLJE | SCIENTIFIC FIELD:**

Strojarstvo / Mechanical Engineering

**NAZIV RADA | TITLE:**

Karakterizacija utjecajnih parametara na trenje u nanometarskom području

Characterization of parameters influencing friction in the nanometric domain

**MENTORI | SUPERVISORS:**

prof. dr. sc. / Prof. D. Sc. Saša Zelenika

prof. dr. sc. / Prof. D. Sc. Igor Mezić

**DATUM OBRANE | DATE OF DEFENCE:**

17.2.2020.

**Sažetak:**

Trenje i trošenje su jedan od najizazovnijih problema u mnogih inženjerskim i proizvodnim tehnologijama. Trenje je nelinearna stohastička pojava s izraženom vremenskom, prostornom i temperaturnom varijabilnošću. U nanometarskom području je proučavanje mehanizama nastanka trenja, parametara koji utječu na trenje te nalaženje odgovarajućeg modela tih pojava još u zametku. Predstavljeno istraživanje daje znanstveni doprinos istraživanju trenja klizanja bez podmazivanja karakterizacijom utjecajnih parametara u nanometarskom području, a posebice ovisnosti ovog fenomena o svojstvima materijala, opterećenju, brzini relativnog gibanja te temperaturi tribološkog para. Eksperimentalno su analizirani tanki filmovi pet različitih materijala. Eksperimentalno mjerenje pretražnim mikroskopom atomskih sila vršeno je na svim uzorcima strukturiranim načinom u eksperimentalnim točkama definiranim triju promjenjivim parametrima: normalna sila, brzina klizanja i temperatura. Razvijenom metodologijom je postignuto prvi puta mjerenje trenja u nano razini sa promjenjive tri veličine. Određivanje korelacijskih funkcija iz dobivenih eksperimentalnih podataka, tj. prediktivnog modela, je izvršeno komparativnom analizom metoda strojnog učenja te je najbolji razvijeni matematički model metodom simboličke

**Summary:**

Friction and wear are one of the most challenging problems in many engineering and manufacturing technologies. In fact, friction is a nonlinear stochastic effect with a marked time, position and temperature variability. While frictional phenomena on the macro- and meso-scales can be considered well described and their effects can be simulated via suitable models as well as generally efficiently compensated by using proper control typologies, the study of the occurrence of friction, the parameters that influence its value and the respective models in the nanometric domain is still in the initial phases. The presented research provides a scientific contribution to the study of dry (unlubricated) friction by characterising the parameters influencing its value at the nanometric scale, and especially the dependence of friction on material properties, loading conditions, the velocity of motion, as well as the temperature. The characterisation of the dependence of friction on the listed parameters is based on experimental measurements performed by employing a Scanning Probe Microscope (SPM), due to the large number of monitored influences, the number and type of measurements is determined by developed Design of Experiment (DoE) method by employing Voronoi tessellations. Furthermore, the measurements are subjected

regresije pokazao točnost predikcije sile trenja u odnosu na radne parametre u rasponu od 72 do 91% ovisno o uzorku. Funkcija ove točnosti predikcije za ovako stohastičku pojavu omogućava ne samo uvid u funkcijsku zavisnost varijabli i potpunu karakterizaciju utjecajnih parametara, nego i buduće proširenje postojećih modela trenja, čime bi se njihova praktična primjenjivost proširila i na nanometarsku razinu.

to numerical experiments carried out by comparative analysis of state-of-the-art machine learning methods to obtain the predictive models linking the process variables to the value of nanometric friction. The developed models show prediction accuracy between 72 and 91% depending on the type of the sample.

**IME I PREZIME | NAME AND SURNAME:**

Iva Šebelja

**POLJE | SCIENTIFIC FIELD:**

Interdisciplinarnе tehničke znanosti / Interdisciplinary Engineering Sciences

**NAZIV RADA | TITLE:**

**Formiranje standardizirane metodologije prijave i izrada referentnih vrijednosti za procjenu učinkovitosti gospodarenja medicinskim otpadom iz zdravstvenih ustanova u Republici Hrvatskoj**

Development of a standardized methodology for reporting and defining of reference values for efficiency assessment of medical waste management from healthcare centers in the Republic of Croatia

**MENTORI | SUPERVISORS:**

izv. prof. dr. sc. / Assoc. Prof. D. Sc. Luka Traven  
prof. dr. sc. / Prof. D. Sc. Duško Pavletić

**DATUM OBRANE | DATE OF DEFENCE:**

24.2.2020.

**Sažetak:**

U Republici Hrvatskoj (RH) ne postoji standardizirana metodologija prijave podataka o količinama i kategorijama otpada koji nastaje tijekom pružanja zdravstvene zaštite – medicinskog otpada. Također nisu definirane referentne vrijednosti za medicinski otpad kao alat za usporedbu s najboljima u klasi. Nepostojanje standardizirane metodologije te definiranih referentnih vrijednosti predstavlja prepreku optimalnom gospodarenju tom vrstom otpada. Svrha ovog rada jest upravo izrada referentnih vrijednosti količina medicinskog otpada koje zdravstvene ustanove proizvode te izrada znanstveno utemeljene i standardizirane metodologije prikupljanja i prijave podataka o količinama pojedinih kategorija medicinskog otpada u RH. Metodologija i definirane regionalne i nacionalne referentne vrijednosti pružaju temelje za kvalitetnije planiranje i gospodarenje medicinskim otpadom u RH te kvantitativnu procjenu performansi pojedine zdravstvene ustanove u području gospodarenja medicinskim otpadom. Osim značaja za Republiku Hrvatsku rezultati dobiveni u ovom radu imaju i međunarodni značaj jer pružaju temelj za slične inicijative u drugim zemljama u regiji i šire.

**Summary:**

The Republic of Croatia so far did not implement a coherent and standardized methodology for gathering data on the generated quantities of medical waste. Also, benchmarking of medical waste as a comparison tool with the best in the class are not defined. This presents a serious obstacle for optimizing the waste management system for this type of waste. This doctoral dissertation defines benchmarks for estimating the amount of medical waste produced by health facilities and develops a scientifically based and standardized methodology for collecting and reporting data on quantities and categories of medical waste in the Republic of Croatia. Methodology and defined regional and national benchmarks sets a scientific base for developing sound and evidence based planning and management initiatives regarding this type of waste in the Republic of Croatia including a quantitative assessment of the performance of individual health care centers. Apart from being of great importance for the Republic of Croatia, the work is relevant for the international scientific community since it offers a starting point for similar actions in other countries in the region and beyond.

**IME I PREZIME | NAME AND SURNAME:**

Marko Valčić

**POLJE | SCIENTIFIC FIELD:**

Brodogradnja / Naval Architecture

**NAZIV RADA | TITLE:**

**Optimizacija alokacije propulzora kod dinamički pozicioniranih plovnih objekata**

Optimization of thruster allocation for dynamically positioned marine vessels

**MENTOR | SUPERVISOR:**

prof. dr. sc. / Prof. D. Sc. Jasna Prpić-Oršić

**DATUM OBRANE | DATE OF DEFENCE:**

6.3.2020.

**Sažetak:**

Postojeće strategije i predložene metode optimalne alokacije propulzora u sustavima za dinamičko pozicioniranje plovnih objekata su primarno usredotočene na minimizaciju potrošnje električne energije uz istovremeno zadovoljavanje brojnih ograničenja i uvjeta. To se posebno odnosi na zasićenje propulzora, kao i na zabranjene zone koje se uobičajeno koriste kako bi se izbjegli ili smanjili gubici poriva uzrokovani međudjelovanjem propulzora. Ostali učinci međudjelovanja propulzora se vrlo rijetko uzimaju u obzir iako mogu uzrokovati značajno smanjenje poriva. To posljedično može dovesti do degradacije pozicije i smjera napredovanja plovnog objekta, te do povećanja vremena odziva i potrošnje električne energije. U sustavima za dinamičko pozicioniranje, nelinearne funkcije cilja te nelinearna ograničenja u obliku jednakosti i nejednakosti ne mogu se izravno uzeti u obzir u optimalnoj alokaciji poriva kod industrijski prihvaćene metode kvadratičnog programiranja. U tom slučaju, nužno je primijeniti odgovarajuću nelinearnu optimizacijsku metodu. Uzimanje u obzir međudjelovanja propulzora u optimizaciji alokacije poriva može optimizacijski problem dodatno transformirati u nelinearan i ne-konveksan, što može biti iznimno zahtjevno. U tom kontekstu, u ovom radu su predložena dva optimizacijska pristupa. Prvi se temelji na otežanoj generaliziranoj inverznoj matrici, a drugi na hibridnom pristupu koji uključuje sekvencijalno kvadratično programiranje, metode direktnog traženja i generaliziranu regresijsku neuronsku mrežu. Potonji pristup je posebno prikladan za rješavanje problema optimalne alokacije poriva vezanih uz općenito nelinearnu ovisnost snage i poriva propulzora, kao i uz ne-konveksnu prirodu zabranjenih zona i međudjelovanja propulzor-propulzor. U odnosu na optimizacijsku strategiju temeljenu isključivo na zabranjenim zonama, oba predložena optimizacijska pristupa mogu uzeti u obzir efekte međudjelovanja propulzora

**Summary:**

Existing strategies and proposed methods for optimal thruster allocation in dynamic positioning systems of marine vessels are primarily focused on minimization of power consumption with handling of numerous constraints and limitations. This particularly applies to thruster saturation and forbidden zones that are usually used in order to avoid or reduce thrust losses due to thruster-thruster interactions. Other thruster interaction effects are rarely taken into account. However, these effects can cause significant thrust losses, which would consequently lead to degradation of vessel position and heading, as well as to increase of response time and power consumption. In optimal thrust allocation procedures, nonlinear objective functions, as well as nonlinear equality and inequality constraints cannot be handled directly by means of the solvers like industry-standardized quadratic programming. In this case, one should use some appropriate nonlinear optimization technique. In addition, implementation of thruster interactions in optimal thrust allocation can easily transform the optimization problem into nonlinear and non-convex, which can become very demanding. In this context, two optimization approaches have been proposed. The first one is based on the weighted generalized inverse matrix approach, and the other one on the hybrid approach using sequential quadratic programming and direct search algorithms coupled with generalized regression neural network. The latter one is particularly convenient for handling non-convex and nonlinear optimization issues related to generally nonlinear power-thrust relationship and to non-convex nature of forbidden zones and thruster interaction effects. Moreover, both optimization approaches can handle selected thruster interaction effects with negligible increase in total power consumption, compared to the strategy based on forbidden zones only, while minimizing the tear and wear of thrusters at



sa zanemarivim povećanjem ukupno utrošene snage, dok se njihovim korištenjem istovremeno minimizira trošenje i habanje propulzora. Dobiveni rezultati su evaluirani kroz brojne simulacije s različitim početnim uvjetima, uz direktnu usporedbu strategija sa zabranjenim zonama i s međudjelovanjem propulzora.

the same time. Obtained results were evaluated with numerous simulations involving different initial conditions and with direct comparison of analysed strategies that include forbidden zones, i.e. thruster-thruster interactions.

**IME I PREZIME | NAME AND SURNAME:**

Graciela Šterpin Valić

**POLJE | SCIENTIFIC FIELD:**

Strojarstvo / Mechanical Engineering

**NAZIV RADA | TITLE:**

**Hlađenje vrtložnom cijevi u kombinaciji s MQL tehnikom podmazivanja pri tokarenju martenzitnog nehrđajućeg čelika**

Vortex tube cooling combined with MQL technique of lubrication when turning of martensitic stainless steel

**MENTOR | SUPERVISOR:**

prof. dr. sc. / Prof. D. Sc. Goran Cukor

**DATUM OBRANE | DATE OF DEFENCE:**

14.5.2020.

**Sažetak:**

Konvencionalne tekućine za obradu metala na osnovi mineralnih ulja su štetne za okoliš i zdravlje ljudi te unose velike dodatne troškove u proizvodnju. Zbog toga su i prepoznate kao glavni neodrživi element procesa strojne obrade pa se sve više razvijaju alternativne tehnike hlađenja i/ili podmazivanja. U tom smislu, jedan od razvojnih pravaca predstavlja i strategija kombiniranja različitih alternativnih tehnika koje se međusobno mogu nadopunjavati prevladavajući ograničenja svake. Ovdje je istražena primjena MQL tehnike podmazivanja u kombinaciji s hlađenjem vrtložnom cijevi kao mogućeg ekološki prihvatljivog rješenja za tokarenje martenzitnog nehrđajućeg čelika X20Cr13. Cilj je bio utvrditi tehnološku i ekonomsku održivost predloženog rješenja u usporedbi s konvencionalnom primjenom emulzije za obradu metala. MQL tehnika podmazivanja, poznata i kao gotovo suha obrada, dostavlja ekstremno male količine biorazgradive tekućine za obradu metala mjerene u mililitrima po satu u zonu rezanja umjesto korištenja konvencionalnih cirkulirajućih poplavnih sustava s emulzijom. Privlači veliku pažnju istraživača jer poštuje jedinstvenu filozofiju "više nije uvijek bolje". S druge strane, zrak kao rashladni medij je potpuno prirodan pa je ova tehnika hlađenja najčišća i ekološki najprihvatljivija. Statistička analiza rezultata eksperimenata prema Taguchijevoj metodi te u kombinaciji s entropijom

**Summary:**

Conventional mineral oil-based metalworking fluids are detrimental to the environment and human health, and they bring significant additional costs to production. As a result, they are also recognized as a major unsustainable element of the machining process, and alternative cooling and/or lubrication techniques are increasingly being developed. In this regard, one of the development directions is the strategy of combining different alternative techniques that can complement each other by overcoming the limitations of each. The application of the MQL lubrication technique in combination with the vortex tube cooling as a possible environmentally friendly solution for turning martensitic stainless steel X20Cr13 is explored herein. The aim was to determine the technological and economic viability of the proposed solution compared to the conventional application of a metalworking emulsion. The MQL lubrication technique, also known as near-dry machining, delivers extremely small amounts of biodegradable metalworking fluid, measured in millilitres per hour, into the cutting zone instead of using conventional circulating emulsion flood systems. It attracts a lot of attention of researchers because it respects the unique philosophy of "more is not always better". On the other hand, air as a cooling medium is completely natural, so this cooling technique is the cleanest and most environmentally friendly. The statistical analysis of the results of

ponderiranom sivom relacijskom analizom i dobivenim regresijskim modelima hrapavosti obrađene površine i postojanosti reznog alata, omogućila je izvođenje zaključaka o tehnološkoj učinkovitosti istraživanih načina hlađenja i/ili podmazivanja. Utvrđen je pozitivan utjecaj MQL tehnike podmazivanja podržane hlađenjem vrtložnom cijevi na hrapavost obrađene površine i postojanost reznog alata. Troškovna evaluacija je omogućila izvođenje zaključaka o ekonomskoj učinkovitosti. Utvrđeno je da je MQL tehnika podmazivanja podržana hlađenjem vrtložnom cijevi troškovno povoljnija u odnosu na konvencionalno hlađenje emulzijom. Zaključuje se da je prijelaz s emulzija na osnovi mineralnih ulja na kombinaciju MQL tehnike podmazivanja i hlađenja vrtložnom cijevi dobar korak prema održivom tokarenju martenzitnog nehrđajućeg čelika X20Cr13 koji rezultira značajnim smanjenjem ekološkog opterećenja i opasnosti za zdravlje ljudi, pri čemu može ponuditi i značajnu ekonomsku korist.

the experiments by the Taguchi method and in combination with the entropy-weighted gray relational analysis, and the obtained regression models of the surface roughness and the tool life, made it possible to draw conclusions about the technological efficiency of the studied cooling and/or lubrication methods. The positive influence of the MQL lubrication technique supported by the vortex tube cooling on the surface roughness and the tool life was determined. The cost evaluation made it possible to draw conclusions on economic efficiency. It has been found that the MQL lubrication technique supported by the vortex tube cooling is more cost-effective than conventional emulsion cooling. It is concluded that the transition from mineral oil-based emulsions to a combination of MQL lubrication and vortex tube cooling is a good step towards the sustainable turning of martensitic stainless steel X20Cr13, resulting in a significant reduction in environmental load and human health hazards, which can offer significant economic benefits.

**IME I PREZIME | NAME AND SURNAME:**

Alen Pavlinić

**POLJE | SCIENTIFIC FIELD:**

Elektrotehnika / Electrical Engineering

**NAZIV RADA | TITLE:**

**Proračun dinamičkoga dopuštenoga termičkog opterećenja nadzemnih vodova**

Calculation of overhead line dynamical thermal rating

**MENTORI | SUPERVISORS:**

izv. prof. dr. sc. / Assoc. Prof. D. Sc. Vitomir Komen

izv. prof. dr. sc. / Assoc. Prof. D. Sc. Dubravko Franković

**DATUM OBRANE | DATE OF DEFENCE:**

15.5.2020.

**Sažetak:**

Dopušteno termičko opterećenje vodiča nadzemnih elektroenergetskih vodova predstavlja ograničenje u trajanju i vrijednosti struje voda s ciljem da se temperatura vodiča održi ispod maksimalno dozvoljene temperature. Stacionarno dopušteno termičko opterećenje je ovisno o frekvenciji, fizikalnim svojstvima vodiča, zemljopisnim parametrima voda te o četiri aksijalno promjenjiva klimatska uvjeta (brzina vjetra, kut vjetra, intenzitet Sunčeva zračenja te temperatura okoline). Dinamičko odnosno kratkotrajno dopušteno termičko opterećenje je pored navedenih veličina ovisno i o početnoj temperaturi vodiča te o definiranom vremenskom periodu za koje se određuje. Kroz rad se sagledavaju razlike i utjecajni parametri pojedinih metodologija proračuna stacionarnoga

**Summary:**

The line ampacity represents a limitation in magnitude and duration of the line current aiming at restricting the conductor temperature below the maximum allowable conductor temperature. The steady-state line ampacity is dependent on the frequency, physical properties of conductor, geographical position of the line and on four axially variable weather parameters (wind speed, wind angle, solar radiation intensity and ambient temperature). The dynamic line ampacity in addition to mentioned parameters is also dependent on the initial conductor temperature and period of calculation. Through the work the differences and impact parameters between the methodologies for steady-state and dynamic line ampacity of aluminium steel-reinforced conductors are analysed. The

odnosno dinamičkog dopuštenog termičkog opterećenja alučeličnih vodiča. Same razlike među metodologijama proračuna određuju se na razini algoritama te ulaznih parametara korištenih u samim proračunima. Dodatno, razlike među metodologijama utvrđuju se numerički za razmatrane slučajeve i analizirane alučelične vodiče. Efekt utjecajnih parametara nadopuštena termička opterećenja sagledava se definiranjem i numeričkim određivanjem koeficijenta osjetljivosti. Posebno se analizira osjetljivost dopuštenih termičkih opterećenja na brzinu vjetra, kut vjetra, intenzitet Sunčeva zračenja te temperaturu okoline. U radu je razvijena izvorna metodologija proračuna dinamičkoga dopuštenog termičkog opterećenja bazirana na rješavanju problema nelinearnog programiranja. Izvršena je reprezentativna usporedba novorazvijene metodologije s postojećim metodama te je time ocijenjena opravdanost njene primjene.

differences between the methodologies are determined upon analysing the algorithms and input parameters used in the calculations. Additionally, the differences are numerically calculated for the analysed cases and aluminium steel-reinforced conductors. The effect of the impact parameters on the line ampacity is examined by defining and numerically calculating the sensitivity coefficients. Through these coefficients the sensitivity of the line ampacity on the wind speed, wind angle, solar radiation intensity and ambient temperature is especially analysed. In addition, a new methodology for calculating the dynamic line ampacity by solving a nonlinear programming problem is developed. This new methodology is compared with the existing methods and the applicability of the new method is discussed.

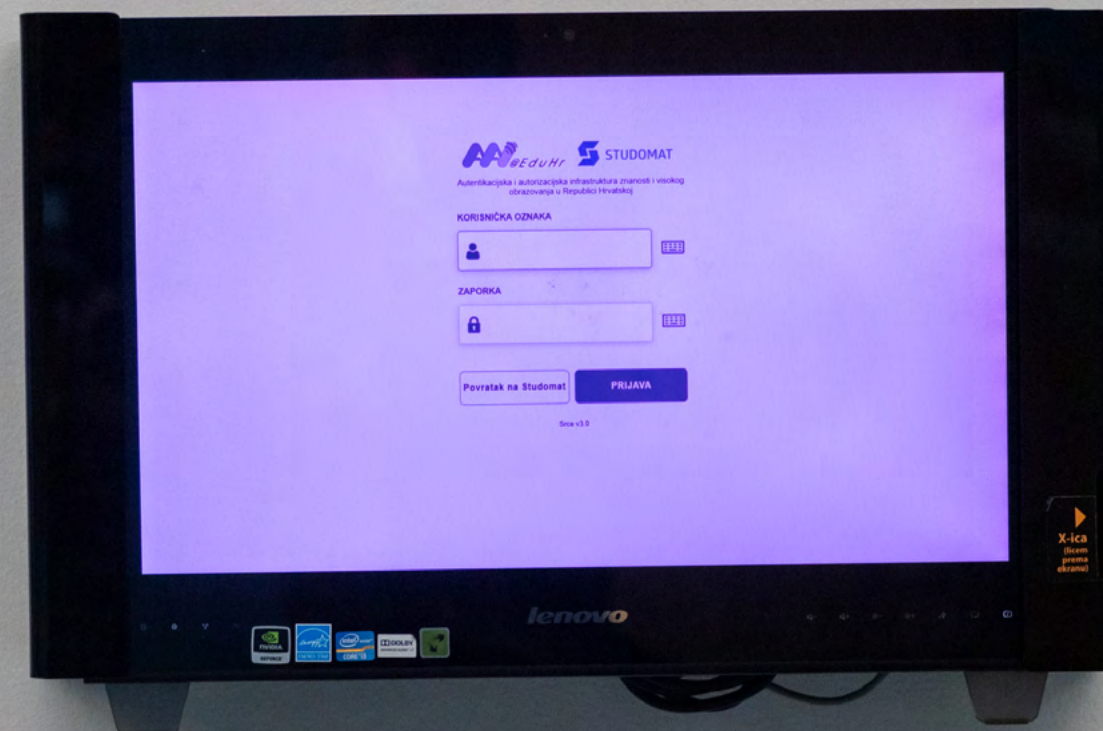





## 2.6 aktivnosti, zbivanja i konferencije activities, events and conferences

### 2.6.1 EU projekti EU projects

#### NAZIV PROJEKTA | PROJECT TITLE:

**MARITIME ENVIRONMENT-FRIENDLY TRANSPORT SYSTEMS – METRO  
2014 - 2020 Interreg V-A Italy - Croatia CBC Programme**

MARITIME ENVIRONMENT-FRIENDLY TRANSPORT SYSTEMS – METRO  
2014 - 2020 Interreg V-A Italy - Croatia CBC Programme

#### Voditelj projekta na Tehničkom fakultetu u Rijeci

Prof. dr. sc. Roko Dejhalla,  
dipl. ing., Tehnički fakultet,  
Sveučilište u Rijeci, Hrvatska

#### The head of the project at the Faculty of Engineering, University of Rijeka

Prof. D.Sc. Roko Dejhalla,  
Faculty of Engineering,  
University of Rijeka, Croatia

#### Članovi projektnog tima

Prof. dr. sc. Jasna Prpić-Oršić, dipl. ing.,  
Tehnički fakultet, Sveučilište u Rijeci, Hrvatska

Prof. dr. sc. Albert Zamarin, dipl. ing.,  
Tehnički fakultet, Sveučilište u Rijeci, Hrvatska

Asist. Davor Bolf, dipl. ing.,  
Tehnički fakultet, Sveučilište u Rijeci, Hrvatska

Darin Majnarić, mag. ing.,  
Tehnički fakultet, Sveučilište u Rijeci, Hrvatska

Lino Josip Novak, mag. ing.,  
Tehnički fakultet, Sveučilište u Rijeci, Hrvatska

Sara Volarić, dipl. oec.,  
Tehnički fakultet, Sveučilište u Rijeci,  
Hrvatska (administrator)

#### Members of the project team

Prof. D.Sc. Jasna Prpić-Oršić,  
Faculty of Engineering, University of Rijeka,  
Croatia

Prof. D.Sc. Albert Zamarin,  
Faculty of Engineering, University of Rijeka,  
Croatia

Asst. Davor Bolf, Nav. Arch.,  
Faculty of Engineering, University of Rijeka,  
Croatia

Darin Majnarić, M. Eng.,  
Faculty of Engineering, University of Rijeka,  
Croatia

Lino Josip Novak, M. Eng.,  
Faculty of Engineering, University of Rijeka,  
Croatia

Sara Volarić, B.Sc. (Econ.),  
Faculty of Engineering, University of Rijeka,  
Croatia (administrator)

#### Sažetak projekta

Projekt METRO je započeo 1. siječnja 2019. godine u sklopu programa prekogranične suradnje Interreg V-A Italija-Hrvatska 2014. - 2020. Vodeći partner projekta je Sveučilište u Trstu dok su ostali partneri u projektu Lučka uprava Trst, Wärtsilä Italia S.p.A., Tehnomont brodogradilište Pula d.o.o., Sveučilište u Rijeci - Pomorski fakultet, Sveučilište u Rijeci - Tehnički fakultet i Istarska razvojna agencija - IDA d.o.o.

Cilj projekta jest poboljšanje održivosti okoliša u području pomorskog prijevoza, kroz multimodalna i zelena rješenja, s posebnim

#### Project summary

METRO project was started on January 1, 2019, as a part of the Italy-Croatia Interreg Cross-Border Cooperation Programme 2014-2020. The leading partner of the project is University of Trieste - Department of Engineering and Architecture, while other partners are Port Network Authority of the Eastern Adriatic Sea, Wärtsilä Italia S.p.A, Tehnomont Shipyard Pula Ltd, University of Rijeka - Faculty of Maritime Studies, University of Rijeka - Faculty of Engineering and Istrian Development Agency - IDA Ltd.

osvrtno na turističke veze na području Sjevernog Jadrana. S tehnološkog stajališta, jedan je od ciljeva projekta razvoj hibridnih brodova kratkog i srednjeg doplova. Pritom su od interesa Ro-Pax brod (brod za prijevoz putnika i vozila) i trajekt s obostranim ukrcajno-iskrcajnim rampama, koji su najčešći tipovi brodova za obalnu plovidbu na području Jadrana. S logističke strane, cilj projekta postigao bi se definiranjem novih ruta između luka Sjevernog Jadrana i izradom studije o prilagodbi infrastrukture za napajanje električnom energijom u manjim pristaništima. U okviru projekta, Tehnički fakultet uključen je u radni paket povezan s projektima brodova.



The project aims to improve the sustainability of the environment in the field of maritime transport, through multimodal and green solutions, with special emphasis on tourist connections in the North Adriatic. From the technological standpoint, one of the goals of the project is the development of hybrid short and medium-sized vessels and of interest are Ro-Pax ferry (passenger and vehicle transport) and double-ended ferry, which are the most common types of coastal vessels in the Adriatic. From a logistical point of view, the objective of the project would be achieved through defining new routes between the ports of the North Adriatic and a study on the adaptation of the electricity supply infrastructure of ships in smaller ports. As part of the project, the Faculty of Engineering is included in the work package related to design of ships.

The main result of METRO project will be an improved quality, safety and environmental sustainability of maritime touristic transport in the North Adriatic Sea, by means of a reinforcement of knowledge exchange among industry and academic partners and a more integrated framework for the adoption of sustainable modes of transport.

#### NAZIV PROJEKTA | PROJECT TITLE:

**ICCT – INTERAKTIVNI TEČAJ ZA AUTOMATSKO UPRAVLJANJE**

ICCT – INTERACTIVE COURSE FOR CONTROL THEORY

#### Voditelj na partnerskoj instituciji

doc. dr. sc. Sandi Ljubić,  
Tehnički fakultet, Sveučilište u Rijeci, Hrvatska

#### Head at a partner institution

Assist. Prof. D. Sc. Sandi Ljubić,  
Faculty of Engineering, University of Rijeka,  
Croatia

#### Članovi tima

**Tehnički fakultet, Sveučilište u Rijeci,  
Hrvatska**

doc. dr. sc. Sandi Ljubić

Alen Salkanović, poslijediplomand

Ana Vranković, poslijediplomand

Luka Batistić, poslijediplomand

Franko Hrzić, poslijediplomand

**Fakulteta za strojništvo, Univerza v Ljubljani,  
Slovenija (prijavitelj Projekta)**

izv. prof. dr. sc. Primož Podržaj

Miha Finžgar, poslijediplomand

**Dipartimento di Ingegneria Civile e  
Industriale, Università di Pisa, Italija**

izv. prof. dr. sc. Michele Lanzetta

izv. prof. dr. sc. Lorenzo Pollini

#### Members of the team

**Faculty of Engineering, University of Rijeka,  
Croatia**

Assist. Prof. D. Sc. Sandi Ljubić

Alen Salkanović, PhD student

Ana Vranković, PhD student

Luka Batistić, PhD student

Franko Hrzić, PhD student

**Faculty of Mechanical Engineering,  
University of Ljubljana, Slovenia  
(Project applicant)**

Assoc. Prof. D. Sc. Primož Podržaj

Miha Finžgar, PhD student

**Department of Civil and Industrial  
Engineering, University of Pisa, Italy**

Assoc. Prof. D. Sc. Michele Lanzetta

Assoc. Prof. D. Sc. Lorenzo Pollini

**Gépezsmérnöki Kar, Budapesti Műszaki és Gazdaságtudományi Egyetem, Mađarska**

prof. dr. sc. Péter Korondi

doc. dr. sc. Budai Csaba

Pizág Bertalan, poslijediplomand

**Faculty of Mechanical Engineering, Budapest University of Technology and Economics, Hungary**

Prof. D. Sc. Péter Korondi

Assist. Prof. D. Sc. Budai Csaba

Pizág Bertalan, PhD student

**Sažetak projekta**

Teorija upravljanja je tema koja pronalazi široku primjenu u inženjerstvu i prirodnim znanostima. Vrlo je čest pojam u elektrotehnici, strojarstvu i procesnom inženjerstvu. Posebno s aspekta Industrije 4.0, jasno je da je potrebno temeljito razumijevanje koncepata koji se poučavaju unutar kolegija povezanih s teorijom upravljanja. Rezultati nedavnih istraživanja ukazuju na to da je studentima teorija upravljanja teška u usporedbi s drugim sadržajima. Odnosni rezultati također otkrivaju da je interaktivni tečaj sa značajkama virtualnog laboratorija preferirani način za učenje relevantne materije. Budući da takvi resursi za učenje nisu dostupni, glavni cilj ovog ERASMUS+ projekta jest razviti internetski interaktivni tečaj i potpurnu web orijentiranu platformu, a u svrhu pružanja jednostavne integracije sadržaja povezanih s teorijom upravljanja. Kako bi se adresirali različiti aspekti u provedbi projekta, uspostavljeno je partnerstvo između četiri sveučilišta (Sveučilište u Ljubljani, Slovenija – strojarstvo, Sveučilište u Pisi, Italija - proizvodno inženjerstvo, Sveučilište u Budimpešti, Mađarska - elektrotehnika i robotika i Sveučilište u Rijeci, Hrvatska – računarstvo). Tijekom razvoja interaktivnog tečaja uspješno se ostvaruje razmjena ideja i dobrih praksi s obzirom na sve dionike (učenike i nastavnike) iz različitih zemalja i s različitim razinom domenskog znanja.

**NAZIV PROJEKTA | PROJECT TITLE:****POVEZIVANJE OBRAZOVNE I ISTRAŽIVAČKE ZAJEDNICE ZA INOVATIVNO DRUŠTVO OSVJEŠTENO OGRANIČENJA RESURSA (COST Akcija)**

CONNECTING EDUCATION AND RESEARCH COMMUNITIES FOR AN INNOVATIVE RESOURCE AWARE SOCIETY (COST Action)

**Predlagatelj projekta**Dr. Gordana Rakić,  
Sveučilište Novi Sad, Prirodno-matematički fakultet, Srbija**Lokalni koordinator**Dr. Goran Mauša,  
Sveučilište u Rijeci, Tehnički fakultet, Hrvatska**Project summary**

Control Theory is a topic that finds a widespread application throughout engineering and natural sciences. It is very common in electrical, mechanical and process engineering. Especially from the Industry 4.0 point of view, it is clear that a thorough understanding of the concepts lectured within Control Theory related subjects is needed. The results of the recent surveys clearly show that students find Control Theory difficult in comparison with other courses. They also show that an interactive course, with a virtual laboratory features, would be a preferred way of studying the corresponding matter. As no such learning resource is available, the main goal of this ERASMUS+ project is to develop an online interactive course and the underlying web-oriented platform, with the purpose of offering smooth integration of the Control Theory related contents. A partnership of four universities is established, so as to cover various aspects in the project implementation (University of Ljubljana, Slovenia – Mechanical Engineering; University of Pisa, Italy – Manufacturing; University of Budapest, Hungary – Electrical Engineering and Robotics; and University of Rijeka, Croatia – Computer Engineering). During the development of the interactive course, an exchange of ideas and good practices is successfully realized, with regard to all the stakeholders (students and teachers) from different countries and with various background knowledge.

**Project proposer**Dr Gordana Rakić,  
University of Novi Sad, Faculty of Science, Serbia**Local coordinator**Dr Goran Mauša,  
University of Rijeka, Faculty of Engineering, Croatia**U partnerstvu s institucijama iz zemalja:**

Belgija, Bosna i Hercegovina, Bugarska, Cipar, Češka Republika, Danska, Estonija, Finska, Francuska, Njemačka, Grčka, Mađarska, Irska, Izrael, Italija, Latvija, Luksemburg, Moldavija, Nizozemska, Norveška, Poljska, Portugal, Rumunjska, Srbija, Slovenija, Španjolska, Švicarska, Ujedinjeno Kraljevstvo

**In partnership with:**

Belgium, Bosnia and Herzegovina, Bulgaria, Cyprus, Czech Republic, Denmark, Estonia, Finland, France, Germany, Greece, Hungary, Ireland, Israel, Italy, Latvia, Luxembourg, Moldova, Netherlands, Norway, Poland, Portugal, Romania, Serbia, Slovenia, Spain, Switzerland, United Kingdom

**Sažetak projekta**

Paralelne računalne platforme revolucionarno su izmijenile hardversku infrastrukturu pružajući obradu podataka visokih performansi, niske potrošnje energije i specijalizirane (naime, heterogene) mogućnosti u različitim domenama primjene, uključujući mobilno i ugradbeno računarstvo, podatkovna središta i računarstvo visokih performansi. Međutim, kako bi iskoristili svoj potencijal, dizajneri sustava moraju uspostaviti teško ostvarivu ravnotežu u raspodjeli resursa komponentama aplikacije, nastojeći izbjeći nedovoljne ili pretjerane odredbe u slučaju najgorih slučajeva profila upotrebe. Problematično povezivanje hardverskih komponentata u nove platforme i složeno ponašanje paralelnih aplikacija podižu oprečne zahtjeve za resursima, više u pametnim, (samo) prilagodljivim i autonomnim sustavima. Ovaj scenarij predstavlja težak izazov razumijevanja i kontroliranja, statički i dinamički, kompromisa u korištenju resursa sustava (vremena, prostora, energije i podataka) iz perspektive napora razvoja i održavanja.

Davanje kompromisa u korištenju resursa pri specifikaciji, tehničkog oblikovanju, implementaciji i za vrijeme izvođenja zahtijeva duboku svijest o lokalnom i globalnom utjecaju uzrokovanom paralelnim dretvama kod aplikacija za pojedinačne resurse. Takva je svijest presudna za akademske istraživače i industrijske djelatnike u svim europskim zemljama i zemljama članicama COST-a i, prema tome, strateški prioritet. Postizanje ovog cilja zahtijeva djelovanje na dvije razine: (1) umrežavanje inače fragmentiranih istraživačkih napora ka cjelovitijim pogledima na problem i rješenja; (2) iskorištavanje odgovarajućih obrazovnih i tehnoloških sredstava za poboljšanje razumijevanja i upravljanja resursima od strane akademske zajednice i industrije ekonomija s lošim učinkom, kako bi se promovirala suradnja unutar Europe i postigle ekonomske i društvene koristi.

**Project summary**

Parallel computing platforms have revolutionised the hardware landscape by providing high-performance, low-energy, and specialized (viz. heterogeneous) processing capabilities to a variety of application domains, including mobile, embedded, data-centre and high-performance computing. However, to leverage their potential, system designers must strike a difficult balance in the apportionment of resources to the application components, striving to avoid under- or over-provisions against worst-case utilisation profiles. The entanglement of hardware components in the emerging platforms and the complex behaviour of parallel applications raise conflicting resource requirements, more so in smart, (self-)adaptive and autonomous systems. This scenario presents the hard challenge of understanding and controlling, statically and dynamically, the trade-offs in the usage of system resources, (time, space, energy, and data), also from the perspective of the development and maintenance efforts.

Making resource-usage trade-offs at specification, design, implementation, and run time requires profound awareness of the local and global impact caused by parallel threads of applications on individual resources. Such awareness is crucial for academic researchers and industrial practitioners across all European and COST member countries, and, therefore, a strategic priority. Reaching this goal requires acting at two levels: (1) networking otherwise fragmented research efforts towards more holistic views of the problem and the solution; (2) leveraging appropriate educational and technology assets to improve the understanding and management of resources by the academia and industry of underperforming economies, in order to promote cooperation inside Europe and achieve economical and societal benefits.

**NAZIV PROJEKTA | PROJECT TITLE:****EUROPSKA MREŽA ZA OSIGURAVANJE INTEGRITETA HRANE KORIŠTENJEM NERAZORNIH SPEKTRALNIH SENZORA – COST AKCIJA CA19145**

EUROPEAN NETWORK FOR ASSURING FOOD INTEGRITY USING NON-DESTRUCTIVE SPECTRAL SENSORS – COST ACTION CA19145

**Predlagatelj projekta**Dolores Perez-Marin,  
University of Cordoba, Španjolska**Project proposer**Dolores Perez-Marin,  
University of Cordoba, Spain**Lokalni koordinator**Ivan Štajduhar,  
Sveučilište u Rijeci, Tehnički fakultet, Hrvatska**Local coordinator**Ivan Štajduhar,  
University of Rijeka, Faculty of Engineering,  
Croatia**U partnerstvu s institucijama iz zemalja:**

Austrija, Belgija, Bugarska, Hrvatska, Cipar, Danska, Estonija, Francuska, Njemačka, Mađarska, Irska, Italija, Malta, Moldavija, Nizozemska, Sjeverna makedonija, Norveška, Poljska, Portugal, Rumunjska, Srbija, Slovenija, Španjolska, Švedska, Turska, Ujedinjeno Kraljevstvo

**In partnership with:**

Austrija, Belgium, Bugaria, Croatia, Cyprus, Denmark, Estonia, France, Germany, Hungary, Ireland, Italy, Malta, Moldova, Netherlands, Northern Macedonia, Norway, Poland, Portugal, Romania, Serbia, Slovenia, Spain, Sweden, Turkey, United Kingdom

**Sažetak projekta**

Unutar prehrambene industrije je sve veća potreba za pružanjem informacija o proizvodima radi zadovoljenja standarda kvalitete i zaštite proizvoda od prijevara s hranom. Najnovija dostignuća u tehnologiji i napredak u analitičkim velikim podacima pružaju priliku za značajnije promjene koje mogu transformirati ulogu osiguranja integriteta hrane iz samo stroge usklađenosti u onu koja se bavi širokim spektrom kritičnih poslovnih problema, uključujući i rješenja za kvalitetu, sigurnost i autentičnost. Nedestruktivni spektroskopski senzori (NDSS) poput NIR spektroskopije, fluorescencije, Ramanovog ili hiperspektralnog snimanja, omogućuju brzu, nerazornu i ekološki sigurnu procjenu višestrukih parametara u raznim prehrambenim proizvodima. Većina primjena ovih tehnologija u prehrambenoj industriji vrši se linijski. Privreda zahtijeva njihovo raspoređivanje in situ i po mogućnosti on-line za potpunu kontrolu procesa nad cijelim prehrambenim lancem. Ovi zahtjevi uvode ograničenja na razvoj dizajna i prilagodbe senzora koji obično nisu primjenjivi na laboratorijske instrumente. Dugoročna stabilnost instrumenata, robusnost kalibracija, integracija senzora u proizvodno okruženje, prenosivost podataka i izgradnja stvarnovremenskog sustava odlučivanja kritična su pitanja koja treba razmotriti. SensorFINT će stvoriti živahnu

**Project summary**

There is an increasing need for the food industry to provide information on their products in order to satisfy quality standards and to protect their products from food fraud. Recent developments in technology, and advances in big data analytics, provide the opportunity for step-changes that can transform the role of food integrity assurance from one of just strictly conformance to one that addresses a wide range of business critical concerns, including quality, safety and authenticity solutions. Non-destructive Spectroscopic Sensors (NDSS), such as NIR Spectroscopy, Fluorescence, Raman or Hyperspectral imaging, enable rapid, non-destructive and environmentally-safe assessment of multiple parameters in a variety of food products. Most applications of these technologies in the food industry are made at-line. Industry requires them to be deployed in situ and preferably on-line for full process control over the entire food chain. These requirements introduce constraints on sensor design and calibration development which do not normally apply to laboratory-based instruments. Long-term stability of instruments, robustness of the calibrations, sensor integration in production environments, transferability of data and the building of real-time decision-making systems are critical issues to be considered. SensorFINT

mrežu kombinirajući iskustvo u istraživanju, proizvodnji, obuci i prijenosu tehnologije u odnosu na NDSS. Akcija će se odvijati razvojem generičkih rješenja za postojeće i nove probleme u neinvazivnoj kontroli prehrambenih procesa izgradnjom "pametnog sustava kontrole hrane", kao i razvojem kadra dobro obučanih mladih istraživača koji će znanstvene rezultate pretvoriti u stvarnost koja odgovara potrebama privrede.

will create a vibrant network, combining experience in research, manufacture, training and technology transfer in relation to NDSS. The Action will operate by developing generic solutions to existing and emerging problems in non-invasive food process control building a "smart food control system" as well as developing a cadre of well-trained young researchers who will convert scientific results into a reality that matches industrial needs.

**NAZIV PROJEKTA | PROJECT TITLE:****MREŽA ZA GRAVITACIJSKE VALOVE, GEOFIZIKU I STROJNO UČENJE – COST AKCIJA CA17137**

A NETWORK FOR GRAVITATIONAL WAVES, GEOPHYSICS AND MACHINE LEARNING – COST ACTION CA17137

**Voditeljica projekta**Dr Elena Cuoco,  
European Gravitational Observatory, Pisa, Italija**Project chair**Dr Elena Cuoco,  
European Gravitational Observatory, Pisa, Italy**Lokalni koordinatori**Jonatan Lerga,  
Sveučilište u Rijeci, Tehnički fakultet, Hrvatska  
Ivan Štajduhar,  
Sveučilište u Rijeci, Tehnički fakultet, Hrvatska**Local coordinator**Jonatan Lerga,  
University of Rijeka, Faculty of Engineering, Croatia  
Ivan Štajduhar,  
University of Rijeka, Faculty of Engineering, Croatia**U partnerstvu s institucijama iz zemalja:**

Belgija, Bosna i Hercegovina, Cipar, Danska, Finska, Francuska, Njemačka, Grčka, Mađarska, Irska, Izrael, Italija, Malta, Moldavija, Crna Gora, Nizozemska, Sjeverna Makedonija, Poljska, Portugal, Rumunjska, Srbija, Slovačka, Španjolska, Švedska, Turska, Ujedinjeno Kraljevstvo, Sjedinjene Američke Države, Australija

**In partnership with:**

Belgium, Bosnia and Herzegovina, Cyprus, Denmark, Finland, France, Germany, Greece, Hungary, Ireland, Israel, Italy, Malta, Moldova, Montenegro, Netherlands, North Macedonia, Poland, Portugal, Romania, Serbia, Slovakia, Spain, Sweden, Turkey, United Kingdom, United States, Australia

**Sažetak projekta**

Značajno otkriće gravitacijskih valova 14. rujna 2015. g. bilo je omogućeno sinergijom tehnika koje se oslanjaju na stručnost u fizici, matematici, informacijskim znanostima i računarstvu. Trenutno postoji veliki interes za strojno učenje, duboko učenje, probleme klasifikacije, dubinsku analizu i vizualizaciju podataka i, općenito, za razvoj novih tehnika i algoritama za učinkovito rukovanje složenim i voluminoznim skupovima podataka poznatih pod nazivom „Big Data“ u raznovrsnim disciplinama, od društvenih do prirodnih znanosti. Brzi porast računalne snage kojom raspolazemo i razvoj inovativnih tehnika za brzu analizu podataka bit će od ključnog značaja za novo uzbudljivo područje astronomije gravitacijskih valova, za specifične teme poput su-

**Project summary**

The breakthrough discovery of gravitational waves on 14 September 2015 was made possible through the synergy of techniques drawing from expertise in physics, mathematics, information science and computing. At present, there is a rapidly growing interest in machine learning, deep learning, classification problems, data mining and visualization and, in general, in the development of new techniques and algorithms for efficiently handling the complex and massive data sets found in what has been coined "Big Data", across a broad range of disciplines, ranging from Social Sciences to Natural Sciences. The rapid increase in computing power at our disposal and the development of innovative techniques for the

stava upravljanja i povratne sprege za sljedeću generaciju detektora, uklanjanja šuma i alata za analizu podataka. Otkriće signala gravitacijskih valova iz sudarajućih binarnih crnih rupa i izgledno postojanje novoopazivne populacije masivnih crnih rupa zvjezdanog podrijetla, učinilo je analizu niskofrekventnih podataka o gravitacijskim valovima presudnom u znanosti o gravitacijskim valovima. Na performanse niskofrekventnih zemaljskih detektora gravitacijskih valova uvelike utječe sposobnost rukovanja potiskivanjem ambijentalnog šuma. Cilj ove akcije je stvaranje široke mreže znanstvenika iz četiri različita područja stručnosti, a to su fizika gravitacijskih valova, geofizika, računarstvo i robotika, sa zajedničkim ciljem rješavanja izazova u analizi podataka i karakterizaciji šuma za detektore gravitacijskih valova.

rapid analysis of data will be vital to the exciting new field of gravitational wave astronomy, on specific topics such as control and feedback systems for next-generation detectors, noise removal and data analysis tools. The discovery of gravitational wave signals from colliding binary black holes and the likely existence of a newly observable population of massive, stellar-origin black holes, has made the analysis of low-frequency gravitational wave data a crucial mission of gravitational wave science. The low-frequency performance of Earth-based GW detectors is largely influenced by the capability of handling ambient seismic noise suppression. This Cost Action aims at creating a broad network of scientists from four different areas of expertise, namely gravitational wave physics, Geophysics, Computing Science and Robotics, with a common goal of tackling challenges in data analysis and noise characterization for gravitational wave detectors.

#### NAZIV PROJEKTA | PROJECT TITLE:

#### RAČUNALNI MODEL STRUJANJA, POPLAVLJIVANJA I ŠIRENJA ONEČIŠĆENJA U RIJEKAMA I OBALNIM MORSKIM PODRUČJIMA - KLIMOD

A COMPUTATIONAL MODEL OF FLOW, FLOODING AND POLLUTION DISPERSION IN RIVERS AND COASTAL MARINE AREAS – KLIMOD

#### Glavni istraživač

prof. dr. sc. Lado Kranjčević,  
Tehnički fakultet, Sveučilište u Rijeci, Hrvatska

#### Članovi istraživačkog tima

izv. prof. dr. sc. Siniša Družeta,  
Tehnički fakultet, Sveučilište u Rijeci, Hrvatska  
doc. dr. sc. Goran Mauša,  
Tehnički fakultet, Sveučilište u Rijeci, Hrvatska  
Luka Grbčić, poslijediplomant,  
Tehnički fakultet, Sveučilište u Rijeci, Hrvatska  
Ivana Lučin, poslijediplomant,  
Tehnički fakultet, Sveučilište u Rijeci, Hrvatska

#### Sažetak projekta

Provedbom projekta provode se primijenjena znanstvena istraživanja i razvija se računalni model za učinkovito modeliranje strujanja i širenja onečišćenja u otvorenim vodotocima i obalnom morskom području, s prihvatom riječnih utoka, bujičnih utoka te industrijskih i kanalizacijskih ispusta u obalno morsko područje, uz istodobni razvoj predikcijskog modela mikrobiološkog onečišćenja baziranog na modelima umjetne

#### Principal investigator

Prof. D. Sc. Lado Kranjčević,  
Faculty of Engineering, University of Rijeka, Croatia

#### Members of the research team

Assoc. Prof. D. Sc. Siniša Družeta,  
Faculty of Engineering, University of Rijeka, Croatia  
Assist. Prof. D. Sc. Goran Mauša,  
Faculty of Engineering, University of Rijeka, Croatia  
Luka Grbčić, Ph. D. student,  
Faculty of Engineering, University of Rijeka, Croatia  
Ivana Lučin, Ph. D. student,  
Faculty of Engineering, University of Rijeka, Croatia

#### Project summary

The project implements applied scientific research and develops a computational model for effective modeling of flow and pollution dispersion in open watercourses and coastal sea area, with the inclusion of river inflows, torrents and industrial and sewage discharges into the coastal sea area, while simultaneously developing a predictive model of microbiological pollution based on artificial intelligence models

inteligencije i integraciju modela širenja onečišćenja mikroplastikom u ukupni model. Računalni model prilagođen je superračunalnom okruženju što omogućuje provođenje simulacija visoke rezolucije s ciljem provođenja mjera za ublažavanje posljedica klimatskih promjena na prioritetnim ranjivim i transverzalnima područjima.

and the integration of microplastic pollution spread models into the overall model. The computational model is adjusted to the supercomputing environment, which enables the implementation of high-resolution simulations with the aim of implementing measures to mitigate the effects of climate change in primarily vulnerable and transversal areas.

#### NAZIV PROJEKTA | PROJECT TITLE:

#### USE OF REGRESSIVE ARTIFICIAL INTELLIGENCE (AI) AND MACHINE LEARNING (ML) METHODS IN MODELLING OF COVID-19 SPREAD - COVIDAI

#### Glavni istraživač

prof. dr. sc. Zlatan Car,  
Tehnički fakultet, Sveučilište u Rijeci, Hrvatska

#### Članovi istraživačkog tima

Nikola Anđelić, asistent  
Tehnički fakultet, Sveučilište u Rijeci, Hrvatska  
Ivan Lorencin, asistent  
Tehnički fakultet, Sveučilište u Rijeci, Hrvatska  
Jelena Musulin,  
stručna suradnica – mlađa istraživačica,  
Tehnički fakultet, Sveučilište u Rijeci, Hrvatska  
Sandi Baressi Šegota,  
stručna suradnica – mlađa istraživačica,  
Tehnički fakultet, Sveučilište u Rijeci, Hrvatska  
Daniel Štifanić,  
stručni suradnik – mlađi istraživač,  
Tehnički fakultet, Sveučilište u Rijeci, Hrvatska

#### Principal investigator

Prof. D. Sc. Zlatan Car,  
Faculty of Engineering, University of Rijeka, Croatia

#### Members of the research team

Nikola Anđelić, Assistant  
Faculty of Engineering, University of Rijeka, Croatia  
Ivan Lorencin, Assistant  
Faculty of Engineering, University of Rijeka, Croatia  
Jelena Musulin,  
Expert Associate – Junior Researcher,  
Faculty of Engineering, University of Rijeka, Croatia  
Sandi Baressi Šegota,  
Expert Associate – Junior Researcher,  
Faculty of Engineering, University of Rijeka, Croatia  
Daniel Štifanić,  
Expert Associate – Junior Researcher,  
Faculty of Engineering, University of Rijeka, Croatia

#### Sažetak projekta

COVIDAI je projekt prihvaćen za financiranje od strane Central European Initiative (CEI).

Cilj projekta je razviti jednostavne modele za upotrebu u području medicine korištenjem algoritama umjetne inteligencije (AI) pomoću superračunalne infrastrukture. Osim pružanja informacija o postojećoj krizi i pružanja regresijskih modela predviđanja temeljenih na dosad prikupljenim podacima, istraživanje će omogućiti širenje znanja o modeliranju visokozaraznih bolesti pomoću tehnika zasnovanih na umjetnoj inteligenciji.

Također, cilj je predstaviti modele jednostavne za upotrebu stvorene AI algoritmom uz pomoć HPC infrastrukture. Uz pružanje informacija o postojećoj krizi i pružanje modela prediktivne regresije na temelju dosad prikupljenih podataka, istraživanje će omogućiti širenje znanja o

#### Project summary

COVIDAI is a project accepted for funding by the Central European Initiative (CEI).

The aim of the project is to develop simple models for medical use using AI algorithms and supercomputer infrastructure. In addition to providing information on the current crisis and providing regression prediction models based on the data collected so far, the research will enable the dissemination of knowledge on modelling highly contagious diseases using techniques based on Artificial Intelligence.

The aim is to present simple-to-use models created using AI algorithms and HPC infrastructure. In addition to providing information in the existing crisis, and providing predictive regression models based on the data collected so far, this piece of research will allow for expanding knowledge on modelling of highly

modeliranju visokozaraznih bolesti pomoću tehnika i algoritama strojnog učenja. To se može pokazati korisnim u određivanju odgovarajućih tehnika, što omogućuje bržu primjenu u mogućim budućim krizama.

Sve navedeno će omogućiti relativno jednostavno integriranje isporučenih modela u postojeće sustave, omogućavajući upotrebu i liječnicima i epidemiolozima, kao sustav stručne podrške. To omogućuje ubrzanje procesa donošenja odluka, što može biti od vitalne važnosti u kriznim situacijama poput ove s kojom se suočavamo.

#### NAZIV PROJEKTA | PROJECT TITLE:

**RAZVOJNO-EDUKACIJSKI CENTAR ZA METALSKU INDUSTRIJU – METALSKA JEZGRA ČAKOVEC**  
DEVELOPMENT AND EDUCATIONAL CENTRE FOR THE METAL INDUSTRY – METAL CENTRE ČAKOVEC

#### Glavni istraživači

prof. dr. sc. Zlatan Car,  
Tehnički fakultet, Sveučilište u Rijeci, Hrvatska  
prof. dr. sc. Roberto Žigulić,  
Tehnički fakultet, Sveučilište u Rijeci, Hrvatska  
prof. dr. sc. Sanjin Braut,  
Tehnički fakultet, Sveučilište u Rijeci, Hrvatska

#### Sažetak projekta

Opći cilj projekta i ustanove Razvojno-edukacijskoga centra za metalSKU industriju – MetalSKU jezgra Čakovec je izgraditi istraživačku infrastrukturu namijenjenu znanstvenoistraživačkoj zajednici za provođenje vrhunskih istraživanja usmjerenih na jačanje znanstvene izvrsnosti, stvaranje društva znanja i povećanje konkurentnosti metalSKU i povezanih industrija na području Međimurske županije i sjeverozapadne Hrvatske.

Infrastrukturni dio aktivnosti uspostavljanja MetalSKU jezgre sufinanciran je iz Operativnog programa Konkurentnost i kohezija, Javnog poziva Ulaganje u organizacijsku reformu i infrastrukturu u sektoru istraživanja, razvoja i inovacija.

U okviru projekta stvorit će se infrastrukturni uvjeti za rad MetalSKU jezgre kroz rekonstrukciju objekta bivše jahaone u okviru Centra znanja Međimurske županije koji se razvija na prostoru bivše vojarnje u Čakovcu i opremanje opremom potrebnom za rad institucije i provođenje aktivnosti istraživanja i razvoja. U svrhu provedbe projekta i daljnjeg razvoja cijele inicijative osnovana je ustanova Razvojno-edukacijski centar za metalSKU industriju – MetalSKU jezgra Čakovec čiji je osnivač Međimurska županija i koja će biti upisana u Upisnik znanstvenih organizacija koji vodi Ministarstvo znanosti i obrazovanja Republike Hrvatske.

infectious diseases using artificial intelligence machine learning techniques and algorithms. This can prove to be useful in determining the appropriate techniques, allowing for faster application in possible future crises.

It should be possible to integrate the delivered models in existing systems relatively easily, allowing their use as expert support systems by doctors and epidemiologists. This allows the possible speed-up of the decision-making process, which can be vital in crisis situations like the one we are experiencing.

#### Principal investigators

Prof. D. Sc. Zlatan Car,  
Faculty of Engineering, University of Rijeka, Croatia  
Prof. D. Sc. Roberto Žigulić,  
Faculty of Engineering, University of Rijeka, Croatia  
Prof. D. Sc. Sanjin Braut,  
Faculty of Engineering, University of Rijeka, Croatia

#### Project summary

The general objective of the project and the Institution Metal Center Čakovec is to build a research infrastructure intended for the scientific research community to conduct top research aimed at strengthening scientific excellence, creating knowledge society and increasing the competitiveness of metal and related industries in the area of Međimurje County and Northwestern Croatia.

The infrastructure part of the founding of the Metals Core is co-financed from the Operational Program Competitiveness and Cohesion, the Public Invitation Investment in organizational reform and infrastructure in the research, development and innovation sectors.

The project will create infrastructure conditions for the operation of the Metals Core through the reconstruction of the former livery stable within the Center of Knowledge of Međimurje County, which is being developed in the area of the former barracks in Čakovec and the equipment needed for the work of the institution and the conduct of research and development activities will be obtained.

The Development and Educational Centre for the Metal Industry – Metal Centre Čakovec was established for the purpose of project implementation and further development of the whole initiative, the founder is Međimurje County and the Metal centre will be enrolled in

the Register of Scientific Organizations led by the Ministry of Science and Education of the Republic of Croatia.

#### NAZIV PROJEKTA | PROJECT TITLE:

**CENTAR KOMPETENCIJA ZA PAMETNE GRADOVE – CEKOM**  
CENTER OF COMPETENCIES FOR SMART CITIES – CEKOM

#### Glavni istraživač

prof. dr. sc. Zlatan Car,  
Tehnički fakultet, Sveučilište u Rijeci, Hrvatska

#### Članovi istraživačkog tima

Adrijana Miočević,  
stručna suradnica – mlađa istraživačica,  
Sveučilište u Rijeci, Hrvatska

Jelena Musulin,  
stručna suradnica – mlađa istraživačica,  
Tehnički fakultet, Sveučilište u Rijeci, Hrvatska

Sandi Baressi Šegota,  
stručna suradnica – mlađa istraživačica,  
Tehnički fakultet, Sveučilište u Rijeci, Hrvatska

Daniel Štifanić,  
stručni suradnik – mlađi istraživač,  
Tehnički fakultet, Sveučilište u Rijeci, Hrvatska

#### Sažetak projekta

CEKOM je skraćena za Centar kompetencija za pametne gradove. Nakon odobrenja bespovratnih sredstava Europske unije iz Operativnog programa Konkurentnost i kohezija, projekt je započeo s radom. Ciljevi projekta su:

- » razvoj novih znanja, iniciranje i podržavanje dugoročne istraživačke suradnje između znanosti i industrije u najkompleksnijim istraživanjima,
- » pozicioniranje grada Rijeke kao testne platforme za provjeru koncepta uz osiguravanje sudjelovanja tehnološki najnaprednijih poduzeća u RH,
- » unaprjeđenje i povezivanje postojeće istraživačke infrastrukture industrije i sveučilišta, uspostava kolaboracijske M2M platforme i integriranje u međunarodne projekte (Horizon 2020, InterReg) gdje će se iskazati kompetencije naših istraživača.

Kroz CEKOM projekt se potiče učinkovitija suradnja privatnog, javnog i znanstvenoistraživačkog sektora u cilju jačanja inovacijskog potencijala gospodarstva i usklađivanje istraživačko-razvojnih strateških planova sa potrebama gospodarstva.

Na CEKOM-u sudjeluje 20 partnera među kojima je i Sveučilište u Rijeci (UNIRI). UNIRI sudjeluje na jednom od 6 glavnih razvojnih projekata,

#### Principal investigator

Prof. D. Sc. Zlatan Car,  
Faculty of Engineering, University of Rijeka, Croatia

#### Members of the research team

Adrijana Miočević,  
Expert Associate – Junior Researcher,  
University of Rijeka, Croatia

Jelena Musulin,  
Expert Associate – Junior Researcher,  
Faculty of Engineering, University of Rijeka, Croatia

Sandi Baressi Šegota,  
Expert Associate – Junior Researcher,  
Faculty of Engineering, University of Rijeka, Croatia

Daniel Štifanić,  
Expert Associate – Junior Researcher,  
Faculty of Engineering, University of Rijeka, Croatia

#### Project summary

CEKOM stands for Center of Competencies for Smart Cities. Following the approval of the European Union grant from the Operational Program Competitiveness and Cohesion, the project started. Project goals are:

- » development of new knowledge, initiating and supporting long-term research cooperation between science and industry in the most complex research,
- » positioning the city of Rijeka as a test platform for testing the concept while ensuring the participation of the most technologically advanced companies in the Republic of Croatia and
- » improving and connecting the existing research infrastructure of industry and universities, establishing a collaborative M2M platform and integrating into international projects (Horizon 2020, InterReg) where the competencies of our researchers will be demonstrated.

The CEKOM project encourages more efficient cooperation between the private, public and scientific-research sectors in order to strengthen the innovation potential of the economy as well as harmonize research and development strategic plans according to the current economy situation.

Smart City 4D – platforma za inovativno mapiranje podzemne infrastrukture. Korištenjem umjetne inteligencije cilj je razviti algoritam za automatsku obradu i automatsko prepoznavanje podzemne infrastrukture.

CEKOM involves 20 partners, including the University of Rijeka (UNIRI). UNIRI participates in one of the 6 main development projects, Smart City 4DII - a platform for innovative mapping of underground infrastructure. Using artificial intelligence, the goal is to develop an algorithm for automatic processing and automatic recognition of underground infrastructure.

#### NAZIV PROJEKTA | PROJECT TITLE:

#### NAPREDNE METODE I TEHNOLOGIJE U ZNANOSTI O PODATCIMA I KOOPERATIVNIM SUSTAVIMA - DATACROSS

ADVANCED METHODS AND TECHNOLOGIES IN DATA SCIENCE AND COOPERATIVE SYSTEMS – DATACROSS

#### Glavni istraživači

prof. dr. sc. Zlatan Car,  
Tehnički fakultet, Sveučilište u Rijeci, Hrvatska  
prof. dr. sc. Viktor Sučić,  
Tehnički fakultet, Sveučilište u Rijeci, Hrvatska  
izv. prof. dr. sc. Kristijan Lenac,  
Tehnički fakultet, Sveučilište u Rijeci, Hrvatska

#### Principal investigators

Prof. D. Sc. Zlatan Car,  
Faculty of Engineering, University of Rijeka, Croatia  
Prof. D. Sc. Viktor Sučić,  
Faculty of Engineering, University of Rijeka, Croatia  
Assoc. Prof. D. Sc. Kristijan Lenac,  
Faculty of Engineering, University of Rijeka, Croatia

#### Članovi istraživačkog tima

Jelena Musulin,  
stručna suradnica – mlađa istraživačica,  
Tehnički fakultet, Sveučilište u Rijeci, Hrvatska  
Domagoj Pinčić,  
stručna suradnica – mlađa istraživačica,  
Tehnički fakultet, Sveučilište u Rijeci, Hrvatska  
Sandi Baressi Šegota,  
stručni suradnik – mlađi istraživač,  
Tehnički fakultet, Sveučilište u Rijeci, Hrvatska  
Daniel Štifanić,  
stručni suradnik – mlađi istraživač,  
Tehnički fakultet, Sveučilište u Rijeci, Hrvatska

#### Members of the research team

Jelena Musulin,  
Expert Associate – Junior Researcher,  
Faculty of Engineering, University of Rijeka, Croatia  
Domagoj Pinčić,  
Expert Associate – Junior Researcher,  
Faculty of Engineering, University of Rijeka, Croatia  
Sandi Baressi Šegota,  
Expert Associate – Junior Researcher,  
Faculty of Engineering, University of Rijeka, Croatia  
Daniel Štifanić,  
Expert Associate – Junior Researcher,  
Faculty of Engineering, University of Rijeka, Croatia

#### Sažetak projekta

DATACROSS je projekt Znanstvenog centra izvrsnosti za znanost o podacima i kooperativnim sustavima koji se bavi istraživačkim problemima razvoja naprednih metoda i tehnologija analize heterogenih podataka te oblikovanja složenih kooperativnih sustava. Ciljevi projekta su:

- » provedba istraživanja u područjima znanosti o podacima i kooperativnim sustavima,
- » povećanje doprinosa razvoju hrvatskog gospodarstva i društva u cjelini,
- » jačanje kapaciteta i povećanje međunarodne vidljivosti i prepoznatljivosti znanstvenog centra izvrsnosti u prethodno navedenim područjima.

#### Project summary

DATACROSS is a project of The Centre of Research Excellence for Data Science and Advanced Cooperative Systems dealing with research problems of developing advanced methods and technologies for heterogeneous data analysis and complex cooperative system shaping. The main project goals are:

- » to conduct top-level researches in the fields of Data Science and Cooperative Systems,
- » to increase the contribution to the development of Croatian economy and society in general and
- » to strengthen the capacity, increase international visibility and recognition of the Centre.

Kroz DATACROSS projekt su organizirane razne aktivnosti podijeljene kroz elemente kao što su napredne metode i tehnologije u znanosti o podacima i kooperativnim sustavima, nabava opreme, međunarodna suradnja, usavršavanje osoblja ZCI-a, promidžba i dr. Kroz DATACROSS projekt se aktivno sudjeluje s gospodarstvom putem razvoja novih visokotehnoloških proizvoda i usluga, diseminacijske aktivnosti i osnivanje spin-off poduzeća.

U sporazumu o prijaviteljima projekta nalazi se i Tehnički fakultet Sveučilišta u Rijeci (RITEH). Kroz projekt, znanstvenici s RITEH-a bave se istraživanjem i razvojem metoda i tehnologija iz raznih polja, a jedno od njih je i primjena umjetne inteligencije. Umjetna inteligencija, zbog svojih brojnih mogućnosti, danas se smatra jednim od najaktivnijih i najzanimljivijih područja znanosti.

DATACROSS project activities are organized in the following elements: advanced methods and technologies in Data Science and Cooperative Systems, procurement of equipment, international cooperation and networking, training and improvement of the Centre's staff, publicity, etc. The DATACROSS project enables active participation in the economy through development of new high-tech products and services, dissemination activities and the establishment of spin-off companies.

One of the project applicants is the Faculty of Engineering, University of Rijeka (RITEH). Through the project, scientists from RITEH are engaged in research and development of methods and technologies from various fields, one of them is the application of Artificial Intelligence (AI). Artificial intelligence, due to its many possibilities, is considered as one of the most active and interesting fields of science.

#### NAZIV PROJEKTA | PROJECT TITLE:

#### NACIONALNI CENTRI KOMPETENCIJA U EUROHPC OKVIRU - EUROCC

NATIONAL COMPETENCE CENTRES IN THE FRAMEWORK OF EUROHPC - EUROCC

#### Članovi istraživačkog tima

Prof. dr. sc. Lado Kranjčević,  
Tehnički fakultet, Sveučilište u Rijeci, Hrvatska  
Izv. prof. dr. sc. Ivan Štajduhar,  
Tehnički fakultet, Sveučilište u Rijeci, Hrvatska  
Doc. dr. sc. Jonatan Lerga,  
Tehnički fakultet, Sveučilište u Rijeci, Hrvatska  
Doc. dr. sc. Goran Mauša,  
Tehnički fakultet, Sveučilište u Rijeci, Hrvatska  
Luka Grbčić, poslijediplomant,  
Tehnički fakultet, Sveučilište u Rijeci, Hrvatska

#### Members of the research team

Prof. D. Sc. Lado Kranjčević,  
Faculty of Engineering, University of Rijeka, Croatia  
Assoc. Prof. D. Sc. Ivan Štajduhar,  
Faculty of Engineering, University of Rijeka, Croatia  
Assist. Prof. D. Sc. Jonatan Lerga,  
Faculty of Engineering, University of Rijeka, Croatia  
Assist. Prof. D. Sc. Goran Mauša,  
Faculty of Engineering, University of Rijeka, Croatia  
Luka Grbčić, Ph. D. student,  
Faculty of Engineering, University of Rijeka, Croatia

#### Sažetak projekta

EuroCC aktivnost okupit će potrebnu stručnost za uspostavljanje mreže nacionalnih centara kompetencija u HPC-u širom Europe u 31 državi članici i pridruženim državama sudionicama, kako bi se pružio širok portfelj usluga prilagođen odgovarajućim nacionalnim potrebama industrije, akademske zajednice i javne uprave. Sve ovo je za potporu i snažno povećanje nacionalnih snaga kompetencija računarstva visokih performansi (HPC), kao i mogućnosti analize podataka visokih performansi (HPDA) i umjetne inteligencije (AI) i za zatvaranje postojećih praznina u povećanju upotrebljivosti ovih tehnologija u različitim državama i tako osigurati izvrsnost europskih standarda.

#### Project summary

The EuroCC activity will bring together the necessary expertise to set up a network of National Competence Centres in HPC across Europe in 31 participating, member and associated states, to provide a broad service portfolio tailored to the respective national needs of industry, academia and public administrations. All of this to support and increase strongly the national strengths of High Performance Computing (HPC) competences as well as High Performance Data Analytics (HPDA) and Artificial Intelligence (AI) capabilities and to close existing gaps to increase usability of these technologies in the different states and thus provide a European excellence baseline.

**NAZIV PROJEKTA | PROJECT TITLE:****OPTIMIZACIJA ISPITNIH KONSTRUKCIJA (ODIN) – COST AKCIJA CA18203**

OPTIMISING DESIGN FOR INSPECTION (ODIN) – COST ACTION CA18203

**Voditeljica projekta**

prof. dr. sc. Rhys Pullin,  
Cardiff University, School of Engineering,  
Cardiff, Ujedinjeno Kraljevstvo

**Lokalni koordinator**

prof. dr. sc. Saša Zelenika,  
Sveučilište u Rijeci, Tehnički fakultet,  
Rijeka, Hrvatska

**Project chair**

Prof. D. Sc. Rhys Pullin,  
Cardiff University, School of Engineering,  
Cardiff, United Kingdom

**Local coordinator**

Prof. D. Sc. Saša Zelenika,  
University of Rijeka, Faculty of Engineering,  
Rijeka, Croatia

**U partnerstvu s institucijama iz zemalja:**

Belgija, Bosna i Hercegovina, Bugarska, Cipar, Češka, Danska, Estonija, Francuska, Grčka, Hrvatska, Irska, Island, Italija, Izrael, Latvija, Litva, Nizozemska, Njemačka, Poljska, Portugal, Rumunjska, Sjeverna Makedonija, Slovenija, Srbija, Španjolska, Švedska, Turska, Ujedinjeno Kraljevstvo, Kanada, Kina, SAD

**In partnership with:**

Belgium, Bosnia and Herzegovina, Bulgaria, Croatia, Cyprus, the Czech Republic, Denmark, Estonia, France, Germany, Greece, Iceland, Ireland, Israel, Italy, Latvia, Lithuania, the Netherlands, North Macedonia, Poland, Portugal, Romania, Serbia, Slovenia, Spain, Sweden, Turkey, the United Kingdom, Canada, China and the USA

**Sažetak projekta**

U laboratorijskim se uvjetima tehnike nerazornog ispitivanja temeljene na ultrazvuku, prikupljanju i pretvorbi niskorazinske energije iz okoliša i bežičnim osjetnicima sve češće pokazuju vrlo učinkovitima pri određivanju oštećenja zrakoplovnih komponenti. Te komponente obuhvaćaju i kritične elemente poput vanjske oplata, motora, opreme za slijetanje i kontrolnih površina zrakoplova. Jasna je, stoga, potreba da se navedeni pristup ispitivanju oštećenja uzme u obzir i integrira već u fazi konstrukcije zrakoplova. Da bi se potaknuo integrativni okvir razvoja optimiziranih autonomnih osjetilnih konstrukcija za dijagnozu i predviđanje oštećenja, ova će COST akcija okupiti vrsne europske stručnjake koji se bave predmetnim područjima te tako omogućiti razvoj prototipova, ali i edukacijskih aktivnosti (uključujući programe obuke), što će u konačnici rezultirati čistim i sigurnijim letovima. Integracijom nerazornih sustava ispitivanja temeljenih na ultrazvučnim valovima sa sustavima prikupljanja i pretvorbe niskorazinske energije iz okoliša i sustavima bežičnih osjetnika već u fazi koncipiranja konstrukcije, ova će COST akcija maksimizirati korist stalnog praćenja oštećenja kritičnih komponenti za vrijeme

**Project summary**

Ultrasound based NDE techniques, energy harvesting and wireless sensor networks are being increasingly demonstrated to be effective in monitoring damage in aerospace components at a laboratory setting. These components include critical elements such as airframe, engines, landing gears and control surfaces. However, there is an urgent need to integrate these approaches and techniques at the inception of an aircraft. This COST Action will bring together the top European experts across these areas to support the development of an integrated framework for optimised self-sensing structures capable of diagnosis and prognosis, together with demonstrators and educational activities, including training programs, which will ultimately lead to cleaner and safer skies. This Action will maximise the full benefit of in service, continuous monitoring of critical aerospace structures by integrating ultrasonic wave based non-destructive evaluation (NDE), energy harvesting and wireless sensor technologies at the design conception phase. Optimisation (sensor/structure), computational modelling, advanced signal processing and advanced design approaches will be integrated

rada zrakoplova. Akcija će, tako, integrirati optimizaciju osjetnika i strukture, numeričko modeliranje, naprednu obradu signala te moderne konstrukcijske pristupe, sve s ciljem da se razviju inovativni tehnološki postupci, konstrukcijski alati i smjernice za dobivanje prvih inačica autonomnih zrakoplovnih konstrukcija koje će omogućiti točno predviđanje strukturnog ponašanja kritičnih komponenti. To će unaprijediti načine održavanja, povećati dostupnost resursa, smanjiti jaz između znanstvenog i industrijskog sektora, omogućiti širu primjenu naprednih materijala, smanjiti radne troškove te, naposljetku, omogućiti sigurnija i ekološki naprednija zrakoplovna prijevozna sredstva.

to produce a novel framework, design tools and guidelines for the delivery of the first generation of a self-sensing aircraft capable of delivering accurate structural prognosis. This will improve maintenance strategies, increase asset availability, bridge the gap between research and industry, enable an increased use of advanced materials, reduce operating costs and ultimately deliver safer and greener air transport solutions.

## 2.6.2 HRZZ projekti HRZZ projects



### NAZIV PROJEKTA | PROJECT TITLE:

**NELOKALNI MEHANIČKI MODELI NANOGREDA**  
NONLOCAL MECHANICAL MODELS OF NANOBAMS

#### Glavni istraživač

prof. dr. sc. Marko Čanađija,  
Tehnički fakultet, Sveučilište u Rijeci, Hrvatska

#### Članovi istraživačkog tima

izv. prof. dr. sc. Marino Brčić,  
Tehnički fakultet, Sveučilište u Rijeci, Hrvatska  
doc. dr. sc. Stefan Ivić,  
Tehnički fakultet, Sveučilište u Rijeci, Hrvatska  
doc. dr. sc. Ante Skoblar,  
Tehnički fakultet, Sveučilište u Rijeci, Hrvatska  
dr. sc. Neven Munjas, pred.,  
Istarsko veleučilište, Hrvatska

Nikola Anđelić, poslijediplomant,  
Tehnički fakultet, Sveučilište u Rijeci, Hrvatska  
Martin Zlatić, poslijediplomant,  
Tehnički fakultet, Sveučilište u Rijeci, Hrvatska

#### Sažetak projekta

Istraživanjem će se razviti napredni nelokalni modeli nanogreda, prikladni za provođenje realističnih simulacija mehaničkog ponašanja nanostrukture. Naime, velika većina rezultata predstavljenih u literaturi uključuje određene manjkavosti. U tom smislu valja istaći dva problema. Često korištena nelokalna gredna formulacija temeljena na gradijentnim metodama daje paradoksalne rezultate u nekim osnovnim problemima. Drugi je problem povezan s mehaničkim značajkama koje su potrebne radi dobivanja rezultata usporedivih s eksperimentima odnosno simulacijama provedenim pomoću molekularne dinamike. Pritom se kao najvažnija mehanička značajka može istaći nelokalni parametar. Točna vrijednost nelokalnog parametra za pojedine materijale uključuje mnoštvo nesigurnosti. Da bi se nadišlo gore opisane paradokse, koristit će se integracijska formulacija temeljena na naprezanjima. Ovo je novi i obećavajući pristup koji nema spomenute poteškoće. Što se pak tiče

#### Principal investigator

Prof. D. Sc. Marko Čanađija,  
Faculty of Engineering, University of Rijeka,  
Croatia

#### Research team members

Assoc. Prof. D. Sc. Marino Brčić,  
Faculty of Engineering,  
University of Rijeka, Croatia  
Assist. Prof. D. Sc. Stefan Ivić,  
Faculty of Engineering,  
University of Rijeka, Croatia  
Assist. Prof. D. Sc. Ante Skoblar,  
Faculty of Engineering,  
University of Rijeka, Croatia  
D. Sc., Neven Munjas, Lecturer,  
Istrian University of Applied Sciences, Croatia  
Nikola Anđelić, PhD student,  
Faculty of Engineering,  
University of Rijeka, Croatia  
Martin Zlatić, PhD student,  
Faculty of Engineering,  
University of Rijeka, Croatia

#### Project summary

The project at hand aims to develop advanced nonlocal models of nanobeams suitable for more realistic simulation of mechanical behavior of nanostructures. The motivation for this research arises from several shortcomings in the majority of the results presented in literature. Two of them have to be pointed out. A widely used gradient based beam nonlocal formulations are prone to paradoxical results if applied to some of the basic bending problems. The other problem is related to mechanical properties that are needed in order to obtain similar results like those obtained experimentally or by molecular dynamics simulations. The most important mechanical property is the nonlocal parameter, but its precise value for a certain material still encompasses a lot of uncertainties. In order to overcome the mentioned paradoxes, the stress-driven integral formulation will be used. This is a novel and promising approach, not suffering from the above described problems. As for the realistic mechanical behavior, in

realističnog mehaničkog ponašanja, da bi se postigao takav cilj mora se uzeti u obzir i diskretnu prirodu nanostrukture. U tom smislu, izotermni procesi deformiranja nanogreda predstavljat će ishodišnu točku, no fokus će biti na neizotermičim problemima. U prvom redu, u tom kontekstu razmatrat će se važna proširenja na dinamičko ponašanje, kao i na kompozitne nanogrede. Razvijene formulacije bit će iskorištene za razvoj novog nelokalnog grednog konačnog elementa koji će biti ugrađen u softver za analizu konačnim elementima Simulia/Abaqus. Novi konačni element omogućit će provođenje niza simulacija s ciljem dobivanja topološki optimalnih struktura s ciljanim značajkama.

### NAZIV PROJEKTA | PROJECT TITLE:

**POVEĆANJE ENERGETSKE UČINKOVITOSTI IZMJENJIVAČA TOPLINE - HEXENER**  
ENHANCEMENT OF THE HEAT EXCHANGER ENERGY EFFICIENCY – HEXENER

#### Glavna istraživačica

prof. dr. sc. Anica Trp,  
Tehnički fakultet, Sveučilište u Rijeci, Hrvatska

#### Članovi istraživačkog tima

prof. dr. sc. Kristian Lenić,  
Tehnički fakultet, Sveučilište u Rijeci, Hrvatska  
prof. dr. sc. Branimir Pavković,  
Tehnički fakultet, Sveučilište u Rijeci, Hrvatska  
izv. prof. dr. sc. Igor Wolf,  
Tehnički fakultet, Sveučilište u Rijeci, Hrvatska  
doc. dr. sc. Paolo Blečić,  
Tehnički fakultet, Sveučilište u Rijeci, Hrvatska  
doc. dr. sc. Igor Bonefačić,  
Tehnički fakultet, Sveučilište u Rijeci, Hrvatska  
doc. dr. sc. Vladimir Glažar,  
Tehnički fakultet, Sveučilište u Rijeci, Hrvatska  
doc. dr. sc. Boris Delač,  
Tehnički fakultet, Sveučilište u Rijeci, Hrvatska  
Josip Batista, poslijediplomant,  
Tehnički fakultet, Sveučilište u Rijeci, Hrvatska  
Mateo Kirinčić, poslijediplomant,  
Tehnički fakultet, Sveučilište u Rijeci, Hrvatska  
Fran Torbarina, poslijediplomant, Tehnički fakultet, Sveučilište u Rijeci, Hrvatska

order to reach such a goal, the discrete nature of nanostructures must be accounted for. Although isothermal deformation of nanobeams will be the starting point, the focus will be on the nonisothermal processes. In particular, those will include important extensions to dynamical effects, as well as to composite materials. The formulations obtained in such a manner will be used to develop a novel nonlocal beam finite element that will be implemented into the finite element software Simulia/Abaqus. With the new finite element, a series of simulations will be performed in order to obtain topologically optimal structures with tailored properties.

#### Principal investigator

Prof. D. Sc. Anica Trp,  
Faculty of Engineering,  
University of Rijeka, Croatia

#### Research team members

Prof. D. Sc. Kristian Lenić,  
Faculty of Engineering,  
University of Rijeka, Croatia  
Prof. D. Sc. Branimir Pavković,  
Faculty of Engineering,  
University of Rijeka, Croatia  
Assoc. Prof. D. Sc. Igor Wolf,  
Faculty of Engineering,  
University of Rijeka, Croatia  
Assist. Prof. D. Sc. Paolo Blečić,  
Faculty of Engineering,  
University of Rijeka, Croatia  
Assist. Prof. D. Sc. Igor Bonefačić,  
Faculty of Engineering,  
University of Rijeka, Croatia  
Assist. Prof. D. Sc. Vladimir Glažar,  
Faculty of Engineering,  
University of Rijeka, Croatia  
Assist. Prof. D. Sc. Boris Delač,  
Faculty of Engineering,  
University of Rijeka, Croatia  
Josip Batista, PhD student,  
Faculty of Engineering,  
University of Rijeka, Croatia  
Mateo Kirinčić, PhD student,  
Faculty of Engineering,  
University of Rijeka, Croatia  
Fran Torbarina, PhD student,  
Faculty of Engineering,  
University of Rijeka, Croatia



**Sažetak projekta**

Predmet istraživanja projekta je povećanje energetske učinkovitosti izmjenjivača topline. Istraživanja će biti usmjerena na analizu izmjene topline i povećanja energetske učinkovitosti raznih tipova lamelnih izmjenjivača topline kao i latentnog spremnika topline kojega možemo smatrati posebnim tipom izmjenjivača. Znanstvenoistraživački ciljevi obuhvaćaju: numeričko i eksperimentalno istraživanje utjecaja geometrijskih karakteristika izmjenjivača topline na fizikalni proces izmjene topline i učinkovitost, numeričko i eksperimentalno istraživanje utjecaja pogonskih uvjeta izmjenjivača topline na fizikalni proces izmjene topline i učinkovitost, numeričko i eksperimentalno istraživanje utjecaja pogonskih uvjeta, geometrije i karakteristika akumulatora topline na izmjenu topline i učinkovitost latentnih spremnika topline te istraživanje pohrane energije u sustavu obnovljivih izvora energije s latentnim spremnikom. Očekivani znanstveni doprinos istraživanja je proširenje postojećih znanstvenih spoznaja vezanih za povećanje energetske učinkovitosti lamelnih izmjenjivača topline, latentnog spremnika topline kao komponente sustava te cijelog sustava obnovljivih izvora energije s latentnim spremnikom.

**Project summary**

The research topic of the project is the enhancement of heat exchanger energy efficiency. Investigations will focus on the analysis of heat transfer and the enhancement of energy efficiency of various fin and tube heat exchangers, as well as of the latent heat storage unit, which is as a special type of heat exchanger. Scientific research objectives include: numerical and experimental investigation of the influence of the heat exchanger geometry characteristics on the physical process of heat transfer and efficiency, numerical and experimental investigation of the influence of the heat exchanger operating conditions on the physical process of heat transfer and efficiency, numerical and experimental investigation of the influence of the latent heat storage operating conditions, geometry and phase change material characteristics on heat transfer and efficiency, as well as analysis of energy storage in the renewable energy system with the latent heat storage unit. The expected scientific contribution of the research is the increase of existing scientific knowledge related to the energy efficiency of fin and tube heat exchangers, latent heat storage as a component of the system and the overall system of renewable energy sources with the latent heat storage.

**Sažetak projekta**

Nove tendencije u konstruiranju, za razliku od konvencionalnih pristupa, zahtijevaju permanentno proširivanje horizonata tehničkih znanja te adekvatan razvoj novih naprednih algoritama prosudbe. Uz eksperimentalna ispitivanja kao zasigurno najpouzdaniji i najučinkovitiji pristup, numeričke se simulacije, zbog znatno nižih troškova, nameću kao nužnost. Kako je u fazi projektiranja konstrukcije od ključne važnosti pravilan izbor materijala, eksperimentalna identifikacija materijalnih značajki iznimno je bitna. Za određeni broj konvencionalnih materijala mehanički su parametri dostupni u literaturi no pojava novih, inovativnih materijala zahtijeva i njihovo eksperimentalno utvrđivanje te je doprinos ovoga projekta djelomično zamišljen i s tim ciljem. Eksperimentalna istraživanja parametara materijala i njegova ponašanja, posebice u specifičnim uvjetima, od iznimne su važnosti za uporabu materijala u odgovarajućim uvjetima eksploatacije.

**Project summary**

The new trends in design, unlike conventional approaches, require the permanent expansion of technical knowledge horizons and the development of new advanced estimation algorithms. Beside the experimental testing as surely the most reliable and most effective approach, numerical simulations, due to considerably lower costs, impose as the necessity. Since the proper choice of materials is of crucial importance in the design phase, experimental determination of material features is extremely important. For some of the conventional materials, mechanical parameters are available in the literature but the emergence of the innovative material requires the new experimental testing. The contribution of this project is partially conceived with this goal. Experimental research of material properties and their behavior, particularly under specific conditions, is of utmost importance for the use of materials under appropriate exploitation conditions.

Znatan će dio istraživanja biti posvećen razvoju novih i nadogradnji postojećih numeričkih simulatora za analizu prostornih grednih konstrukcija, s posebnim naglaskom na tankostijene gredne konstrukcije izvedene od novih, naprednih materijala kompozitnog tipa, kao npr. laminati, FG materijali i drugi, a u režimima ekstremnih uvjeta, npr. povišenih i sniženih temperatura i vlažnosti. Cilj simulacija bit će procijeniti moć nošenja konstrukcije odnosno predvidjeti pojavu graničnog stanja s osvrtom na razloge nastupanja kolapsa. Kao potpora cjelovitom modelu prosudbe, kako u normalnim eksploatacijskim uvjetima, tako i u uvjetima graničnih stanja, a s obzirom na višegodišnje iskustvo istraživačkog tima i već postojeću znanstvenu opremu, u prvom redu, vršit će se statička i dinamička eksperimentalna ispitivanja različitih konstrukcijskih materijala s naglaskom na određivanje do sada nedostupnih mehaničkih/materijalnih parametara specijalnih metalnih materijala (legura), od utvrđivanja statičke i dinamičke čvrstoće u ekstremnim uvjetima, pa do analize i praćenja širenja pukotina kao posljedice cikličkog zamora. U okviru ovoga projekta, eksperimentalno dobiveni podaci doprinijet će formiranju novih te nadopuni postojećih baza materijalnih značajki s ciljem podloge računalnim simulatorima kao osnovnom rezultatu predloženoga projekta.

The large portion of research will be dedicated to the development of new and upgrading of existing numerical simulators for spatial beam structures, with a particular emphasis on thin walled beams made of composite materials, e.g. laminates, functionally graded, etc. in the extreme conditions such as elevated and reduced temperature and humidity. The main aim of the simulations will be to estimate the load carrying capacity of structure, or to predict the occurrence of the limit state with the respect of the reasons of collapse. As a support to the complete model of limit load state assessment, both in normal exploitation conditions and in limit load states, respecting the many years of experience of the project team and the existing scientific equipment, the static and dynamic experimental testing of various structural materials will be carried out. It will refer to the determination of the unavailable mechanical/material parameters, of e.g. some special metal alloys, such as static and dynamic strength in extreme conditions or analysis and monitoring of fatigue cracks as consequence of cyclic fatigue. By this project, the experimentally obtained data, will contribute to the creation of new material databases as well as the supplement of the existing ones. The final goal of these material databases will be to support the computer simulators as the basic result of the proposed project.

**NAZIV PROJEKTA | PROJECT TITLE:**

**PROCJENA GRANIČNE NOSIVOSTI INŽENJERSKIH KONSTRUKCIJA - LOCAPES**  
ESTIMATION OF LIMIT LOAD CAPACITY OF ENGINEERING STRUCTURES - LOCAPES

**Glavni istraživač**

Prof. dr. sc. Domagoj Lanc,  
Tehnički fakultet, Sveučilište u Rijeci

**Principal investigator**

Prof. D. Sc. Domagoj Lanc,  
Faculty of Engineering, University of Rijeka

**Članovi istraživačkog tima**

Prof. dr. sc. Goran Turkalj,  
Tehnički fakultet, Sveučilište u Rijeci  
Prof. dr. sc. Josip Brnić, Prof. Emeritus,  
Tehnički fakultet, Sveučilište u Rijeci  
Doc. dr. sc. Igor Pešić,  
Odsjek za politehniku, Sveučilište u Rijeci  
Doc. dr. sc. Sanjin Krščanski,  
Tehnički fakultet, Sveučilište u Rijeci  
Asist. Damjan Banić, poslijediplomant,  
Tehnički fakultet, Sveučilište u Rijeci  
Asist. Sandra Kvaternik, poslijediplomant,  
Tehnički fakultet, Sveučilište u Rijeci

**Research team members**

Prof. D. Sc. Goran Turkalj,  
Faculty of Engineering, University of Rijeka  
Prof. D. Sc. Josip Brnić, Prof. Emeritus,  
Faculty of Engineering, University of Rijeka  
Assist. Prof. D. Sc. Igor Pešić,  
Department of Polytechnics, University of Rijeka  
Assist. Prof. D. Sc. Sanjin Krščanski,  
Faculty of Engineering, University of Rijeka  
Damjan Banić, PhD student,  
Faculty of Engineering, University of Rijeka  
Sandra Kvaternik, PhD student,  
Faculty of Engineering, University of Rijeka

**NAZIV PROJEKTA | PROJECT TITLE:****SUSTAV POTPORE ODLUČIVANJU ZA ZELENIJU I SIGURNIJU PLOVIDBU BRODOVA - DESSERT**  
DECISION SUPPORT SYSTEM FOR GREEN AND SAFE SHIP ROUTING - DESSERT**Glavna istraživačica**

prof. dr. sc. Jasna Prpić – Oršić,  
Tehnički fakultet, Sveučilište u Rijeci, Hrvatska

**Principal investigator**

Prof. D. Sc. Jasna Prpić – Oršić,  
Faculty of Engineering, University of Rijeka,  
Croatia

**Članovi istraživačkog tima**

prof. dr. sc. Odd Magnus Faltinsen,  
Norveško sveučilište znanosti i tehnologije,  
Trondheim, Norveška  
prof. dr. sc. Kenji Sasa,  
Kobe University, Zavod za pomorstvo, Kobe,  
Japan  
prof. dr. sc. Tomislav Mrakovčić,  
Tehnički fakultet, Sveučilište u Rijeci, Hrvatska  
prof. dr. sc. Duško Pavlečić,  
Tehnički fakultet, Sveučilište u Rijeci, Hrvatska  
doc. dr. sc. Jonatan Lerga,  
Tehnički fakultet, Sveučilište u Rijeci, Hrvatska  
doc. dr. sc. Vedran Mrzljak,  
Tehnički fakultet, Sveučilište u Rijeci, Hrvatska  
doc. dr. sc. Marko Valčić,  
Tehnički fakultet, Sveučilište u Rijeci, Hrvatska  
izv. prof. dr. sc. Igor Rudan,  
Pomorski fakultet, Sveučilište u Rijeci, Hrvatska  
doc. dr. sc. Srđan Žuškin,  
Pomorski fakultet, Sveučilište u Rijeci, Hrvatska  
dr. sc. Francesco Mauro,  
Sveučilište u Trstu, Trst, Italija  
Luca Braidotti, Sveučilište u Trstu, Trst, Italija  
Natalija Vitali, poslijediplomantica,  
Tehnički fakultet, Sveučilište u Rijeci, Hrvatska

**Research team members**

Prof. D. Sc. Odd Magnus Faltinsen,  
Norwegian University of Science and  
Technology, Trondheim, Norway  
Prof. D. Sc. Kenji Sasa,  
Kobe University, Department of Maritime  
Sciences, Kobe, Japan  
Prof. D. Sc. Tomislav Mrakovčić,  
Faculty of Engineering, University of Rijeka,  
Croatia  
Prof. D. Sc. Duško Pavlečić,  
Faculty of Engineering, University of Rijeka,  
Croatia  
Assist. Prof. D. Sc. Jonatan Lerga,  
Faculty of Engineering, University of Rijeka,  
Croatia  
Assist. Prof. D. Sc. Vedran Mrzljak,  
Faculty of Engineering, University of Rijeka,  
Croatia  
Assist. D. Sc. Marko Valčić,  
Faculty of Engineering, University of Rijeka,  
Croatia  
Assoc. Prof. D. Sc. Igor Rudan,  
Faculty of Maritime Studies, University of  
Rijeka, Croatia  
Assist. Prof. D. Sc. Srđan Žuškin,  
Faculty of Maritime Studies, University of  
Rijeka, Croatia  
D. Sc. Francesco Mauro,  
University of Trieste, Trieste, Italy  
Luca Braidotti,  
University of Trieste, Trieste, Italy  
Natalija Vitali, PhD student,  
Faculty of Engineering, University of Rijeka,  
Croatia

**Sažetak projekta**

Cilj istraživanja u okviru projekta Sustav potpore odlučivanju za zeleniju i sigurniju plovidbu brodova (DESSERT) je razvoj učinkovitog sustava potpore odlučivanju (Decision Support System - DSS) kapetanima broda, kao i zapovjednicima stroja, a koji bi doprinio "zelenijoj" i sigurnijoj plovidbi brodova. Krajnji učinak takvog DSS bilo bi svođenje ljudske pogreške na što manju mjeru odnosno pružanje

**Project summary**

The research goal in the framework of the project DEcision Support System for green and safe ship navigation– DESSERT is the development of an effective Decision Support System (DSS) for captains as well as for machine commanders, which would contribute to "greener" and safer navigation of ships. The ultimate effect of such a DSS would be the reduction of human errors to a minimum, i.e. offering the most credible data and

maksimalno vjerodostojnih podataka i smjernica odgovornim osobama na brodu tijekom plovidbe radi smanjenja onečišćenje okoliša i sigurnosti ljudi i tereta.

Istraživanja vezana uz razvoj DSS-a odvijat će se u dva osnovna smjera: energetska učinkovitija plovidba uz smanjenje emisije stakleničkih plinova i povećanje sigurnosti plovidbe s aspekta izbjegavanja sudara

Cilj je razviti sustav potpore odlučivanju na brodu uzimajući u obzir projektantsku, strojarsku i pomorsku ekspertizu u cilju stvaranja sigurnog i ekološki učinkovitog ili "zelenijeg" broda i plovidbe. Projektni tim sastoji se od znanstvenika koji su stručnjaci u brodogradnji, strojarstvu, pomorskom inženjerstvu i računarstvu i koji omogućuju multidisciplinarno rješavanje ovog problema.

guidance to authorised people on board during navigation in order to reduce the environmental pollution and increase in people and cargo safety.

Research related to the development of DSS will take place in two main directions: energy-efficient navigation along with the reduction of greenhouse gas emissions as well as an increase in navigation safety so as to avoid collision.

The objective is to develop a decision support system on board taking into account design, mechanical and maritime expertise in order to create a safe and environmental friendly or "greener" ship and navigation. The project team consists of scientists, experts in naval architecture, mechanical engineering, marine engineering and computer engineering, which allows a multidisciplinary approach to problem solving.

**NAZIV PROJEKTA | PROJECT TITLE:****MODELIRANJE I SIMULACIJA U RAZVOJU NAPREDNIH MATERIJALA - SIMMAT**  
MODELLING AND SIMULATION IN ADVANCED MATERIALS DEVELOPMENT - SIMMAT**Glavna istraživačica**

prof. dr. sc. Marina Franulović,  
Tehnički fakultet, Sveučilište u Rijeci, Hrvatska

**Principal investigator**

Prof. D. Sc. Marina Franulović,  
Faculty of Engineering, University of Rijeka

**Članovi istraživačkog tima**

prof. dr. sc. Dražan Kozak,  
Strojarski fakultet u Slavonskom Brodu,  
Sveučilište u Slavonskom Brodu  
doc. dr. sc. Kristina Marković,  
Tehnički fakultet, Sveučilište u Rijeci  
Matej Gljuščić, doktorand,  
Tehnički fakultet, Sveučilište u Rijeci  
David Liović, doktorand,  
Tehnički fakultet, Sveučilište u Rijeci  
Maja Dundović, doktorandica,  
Tehnički fakultet, Sveučilište u Rijeci

**Research team members**

Prof. D. Sc. Dražan Kozak,  
Mechanical Engineering Faculty,  
University of Slavonski Brod  
Assist. Prof. D. Sc. Kristina Marković,  
Faculty of Engineering, University of Rijeka  
Matej Gljuščić, PhD student,  
Faculty of Engineering, University of Rijeka  
David Liović, PhD student,  
Faculty of Engineering, University of Rijeka  
Maja Dundović, PhD student,  
Faculty of Engineering, University of Rijeka

**Sažetak projekta**

Visoka razina tržišnog natjecanja danas postavlja putokaze za razvoj novih tehnologija u dizajnu strojarskih konstrukcija i predstavlja značajne izazove konstruktorima. Razvoj novih tehnologija, s jedne strane, proširuje mogućnosti optimizacije dizajna strojarskih konstrukcija, a s druge strane kao imperativ postavlja potrebu istraživanja ponašanja inovativnih materijala koji mogu ispuniti zahtjeve ovih tehnologija, a istovremeno ispuniti i kriterije čvrstoće, krutosti i stabilnosti konstrukcija. Tijekom rada na završenom projektu BIOMAT HRZZ-a, kontinuirano se vršilo istraživanje mogućnosti

**Project summary**

High level of competitiveness on the marketplace today increases the importance in the development of new technologies in the design of mechanical structures and represents significant challenges for mechanical engineering constructors. The development of new technologies, on the one hand, expands the possibilities of optimization of mechanical engineering designs, and on the other hand, as an imperative, raises the need for research of the behavior of innovative materials which can meet the design requirements of these technologies. Besides the design requirements, components

primjene razvijene metodologije za modeliranje i simulaciju ponašanja biomaterijala na inovativne i nekonvencionalne materijale. Posljedično, sistematizacija informacija o materijalima širokog spektra karakteristika i mogućnosti primjene i sistematizacija materijalnih modela upućivala je na relevantnost i potrebu za istraživanjem ponašanja ovih materijala. Nadalje, uočila se posebnost u strukturi bioloških materijala promatrana kao korelacija matrice i kolagenskih vlakana i njihova sličnost s kompozitnim strukturama, pa su se, kroz sveobuhvatnu analizu potencijala za istraživanje inovativnih materijala, istraživanja usmjerila upravo prema kompozitnim strukturama. Uočena je i potreba za usvajanjem znanja o ponašanju titanijevih legura te je istraživanje njihovog ponašanja prepoznato kao povezan sekundarni cilj istraživanja. Razvoj novih tehnologija fokus projekta je dodatno usmjerio prema istraživanju ponašanja ovih materijala dobivenih aditivnim tehnologijama. Istraživanje u okviru projekta SIMMAT predstavlja nastavak prethodnih istraživanja tako da se razvijena metodologija, efikasna kako za metalne tako i za biološke materijale, prilagodi i primijeni na karakterizaciju, simulaciju i analizu ponašanja i usvajanje potrebnih znanja o spomenutim materijalima dobivenim aditivnim tehnologijama.

S obzirom na visoku anizotropnost kao rezultat same aditivne tehnologije i povećanjem stupnja anizotropnosti adicijom vlakana, projektiranje i analiza konstrukcija od aditivnih polimera i kompozita iziskuje poznavanje većeg broja materijalnih parametara, sukladno primjeni složenih materijalnih modela. U projektu je stoga predviđeno utvrđivanje i provedba postupka karakterizacije kompozitnih materijala i titanijevih legura izrađenih aditivnim tehnologijama i validacija rezultata metodom fotoelastimetrije na stvarnim strojnim dijelovima.

Projekt je u skladu sa Strategijom Pametne specijalizacije RH u kojoj je jedan od prioriteta istraživanje u području znanosti o materijalima i proizvodnim tehnologijama. U osnovi, primjena naprednih materijala u razvoju novih proizvoda predstavlja udovoljavanje potrebama novih tehnologija kroz održivi razvoj. Naime, rezultati ovog istraživanja, posebice razvoj i validacija procedura za karakterizaciju i modeliranje ponašanja naprednih materijala proizvedenih aditivnim tehnologijama, doprinijet će očuvanju okoliša (minimiziranje mase proizvoda, veća trajnost proizvoda, smanjenje potrošnje energije pri proizvodnji i eksploataciji, povećana vjerojatnost uporabe proizvoda, povećana tehnološkičnost, smanjenje količine otpada i slično), razvoju gospodarstva RH (povećana ekonomičnost s ciljem međunarodne konkurentnosti) i razvoju društva. Nadalje, projekt

have to fulfill the set criteria of strength, rigidity and stability of construction in order to achieve the required load-bearing capacity. Considering the need to investigate the behavior of innovative materials, within the framework of the previous research carried out through the project "Development of evolutionary procedures for characterization of biological tissues behavior - BIOMAT", the preconditions for further improvement of methodology and solutions were created for the characterization of innovative and unconventional materials and their application in engineering practice. As a result, systematization of information on materials of a broad spectrum of characteristics and application possibilities and the systematization of material models indicated the relevance and need to investigate the behavior of these materials. Special attention has been given to the structure of biological materials that is considered through the correlation of matrices and collagen fibers which appears similar to the composite structures. Consequently, with a comprehensive analysis of the potential for the exploration of innovative materials, it directed the research to the composite structures. On the other hand, the need to adopt knowledge of the behavior of titanium alloys has been identified and the research of their behavior is recognized as the secondary objective of the research. The development of new technology focuses further on the research on the behavior of these materials produced using additive technologies. The research is a continuation of previous research in a way that the developed methodology, efficient for both metallic and biological materials, will be adapted and applied to the characterization, simulation and behavior analysis as well as to acquire the necessary knowledge on the behavior of materials produced by additive technologies.

Anisotropy in materials structure is expected in components manufactured using additive technologies and it is expected to further increase by the addition of fibers. As a result, designing and analyzing additively produced composites require wide knowledge of its mechanical properties and consequently on a large number of material parameters in accordance with the application of complex material models. The project therefore provides for the determination and implementation of the characterization process of composite materials and titanium alloys produced by additive technologies, as well as validation of results by photoelastimetry on real machine parts. Consequently, the research results are expected to provide the possibility to evaluate and predict the lifespan of the construction made from the observed materials during the exploitation.

ima utjecaj na promicanje načela inovativnog i otvorenog društva kroz razvoj dobrog upravljanja uključivanjem osobe koje će na djelotvoran i ekonomičan način u kratko vrijeme doprinijeti kvaliteti istraživanja i promicanju fakultetskog, sveučilišnog i nacionalnog identiteta. Rezultati istraživanja bit će dostupni zainteresiranoj javnosti diseminacijom radi osiguranja transparentnost i poticanja inovativnost i kreativnog razmišljanja u širokoj znanstvenoj zajednici i gospodarskim subjektima.

The project is in accordance with the adopted Smart Specialization Strategy of the Republic of Croatia, where one of the set priorities is research in the field of materials science and production technologies. Here, the development of new products by the application of advanced materials through new technologies represents the main point in satisfying the sustainable development goals. Specifically, the results of this research, particularly the development and validation of procedures for characterization and modeling the behavior of advanced materials produced by additive technologies, will contribute to environmental protection (minimizing product mass, extending product durability, reducing energy consumption in production and exploitation, increased product recovery probability, waste reduction, etc.), the development of the Croatian economy (increased economy with the aim of international competitiveness) and the development of society. Furthermore, the project has an impact on promoting the principles of an innovative and open society through the development of good governance by involving people who will in a cost-effective manner contribute to the quality of research and the promotion of faculty, university and national identity in a short time. Dissemination of research results will be available to the public to ensure transparency and stimulate innovation and creative thinking in the broader scientific community.

## 2.6.3 job.fair i dan otvorenih laboratorija 2019

### job.fair and open lab day 2019

Dana 24. listopada 2019. godine na Tehničkom fakultetu u Rijeci održana je treća po redu Job.Fair manifestacija koja je obuhvatila prezentacije laboratorija Tehničkog fakulteta, prezentacije studija i partnerskih tvrtki s kojima Tehnički fakultet surađuje na znanstvenostručnim projektima.

I ove godine predstavnici tvrtki su kroz interaktivna izlaganja putem izložbenih prostora u auli Fakulteta predstavili svoj rad, neke od projekata i područja kojima se bave. Na ovogodišnjoj Job.Fair manifestaciji sudjelovala su 23 privredna subjekta i to: HEP d.d. iz Zagreba, AITAC d.o.o. iz Kastva, Danieli - Systec d.o.o. iz Labina, iOLAP d.o.o. iz Rijeke, PK-Palfinger Kran d.o.o. iz Škriljeva, CROZ d.o.o. iz Zagreba, Klimaoprema d.d. iz Samobora, IHC Engineering Croatia d.o.o. iz Rijeke, Span d.o.o. iz Zagreba, INETEC d.o.o. iz Zagreba, Elcon Geraetebau d.o.o. iz Rijeke, Infobip d.o.o. iz Vodnjana, TSI d.o.o. iz Rijeke, SAIPEM S.p.A. Croatian Branch iz Rijeke, Hrvatski Telekom d.d. iz Zagreba, Uljanik Tesu elektronika d.o.o. iz Pule te predstavnici austrijskog gospodarstva u Hrvatskoj: Austrian Business Agency GmbH, Axess AG, BearingPoint GmbH, EBCONT enterprise technologies GmbH, epunkt GmbH, Lakeside Science & Technology Park GmbH, SSI Schäfer IT Solutions GmbH.

The 3rd Job.Fair event was held at the Faculty of Engineering Rijeka on October, 24th 2019, which included presentations of the Faculty laboratories, presentations of study programs and partner companies with which the Faculty of Engineering cooperates on scientific projects.

This year as well, the representatives of the companies presented their work, some of the projects and aspects of their business, through interactive presentations at the exhibition spaces in the Faculty main hall. This year's Job.Fair event was attended by 23 business entities, namely: HEP d.d. from Zagreb, AITAC d.o.o. from Kastav, Danieli - Systec d.o.o. from Labin, iOLAP d.o.o. from Rijeka, PK-Palfinger Kran d.o.o. from Škriljevo, CROZ d.o.o. from Zagreb, Klimaoprema d.d. from Samobor, IHC Engineering Croatia d.o.o. from Rijeka, Span d.o.o. from Zagreb, INETEC d.o.o. from Zagreb, Elcon Geraetebau d.o.o. from Rijeka, Infobip d.o.o. from Vodnjan, TSI d.o.o. from Rijeka, SAIPEM S.p.A. Croatian Branch from Rijeka, Hrvatski Telekom d.d. from Zagreb, Uljanik Tesu elektronika d.o.o. from Pula and representatives of the Austrian economy in Croatia: Austrian Business Agency GmbH, Axess AG, BearingPoint GmbH, EBCONT enterprise technologies GmbH, epunkt GmbH, Lakeside Science & Technology Park GmbH, SSI Schäfer IT Solutions GmbH.



U okviru Job.Faira-a održan je i Dan otvorenih laboratorija tijekom kojeg su učenici srednjih škola Primorsko – goranske županije i Istarske županije, te srednjoškolci iz Slunja, osim posjeta laboratorijima Tehničkog fakulteta, mogli više saznati o tehnološkim postignućima i alatima koji se koriste u sklopu laboratorija. Manifestacija je također omogućila sadašnjim učenicima srednjih škola, a potencijalnim budućim studentima proširiti vidike koji će im pomoći kod odabira željenog Fakulteta i prednostima koje diploma Tehničkog fakulteta pruža na tržištu rada. U izuzetno uspješnoj manifestaciji sudjelovalo je oko 260 učenika uz pratnju odgovornih osoba sljedećih srednjih škola:

- » Srednja škola za elektrotehniku i računalstvo, Rijeka
- » Tehnička škola za strojarstvo i brodogradnju Rijeka
- » Prva riječka hrvatska gimnazija
- » Prva Sušačka hrvatska gimnazija Rijeka
- » Gimnazija i strukovna škola Jurja Dobrile, Pazin
- » Tehnička škola Pula
- » Srednja škola Mate Blažine Labin
- » Srednja škola Slunj



As part of the Job.fair, the Open Laboratories Day was held, during which high school students from Primorsko – Goranska county and Istria county, as well as high school students from Slunj, in addition to visiting the laboratories of the Faculty of Engineering, could learn more about technological achievements and tools used in the laboratory works. The event also allowed current high school students and potential prospective university students to broaden their horizons, to help them choose the desired Faculty and the benefits that a Faculty of Engineering degree provides on the job market. About 260 students participated in the extremely successful event, accompanied by the responsible persons of the following high schools:

- » High School of Electrical Engineering and Computing, Rijeka
- » Technical School of Mechanical Engineering and Naval Architecture Rijeka
- » The First Croatian Grammar School in Rijeka
- » The First Sušak Croatian Grammar School, Rijeka
- » Grammar School and Vocational School Juraj Dobrila, Pazin
- » Technical School, Pula
- » High School Mate Blažina, Labin
- » High School in Slunj





Grupe učenika su se u predviđenom rasporedu izmjenjivale na deset postaja – devet laboratorija te zajednička postaja na kojima su predstavljeni studentski projekti. Dodatno, učenicima je omogućeno da nakon organiziranog posjeta pokaznim mjestima, po vlastitom izboru naknadno posjete bilo koje pokazno mjesto te dodatna dva pokazna mjesta, Solarna elektrana i Trafostanica. Proveden je sljedeći program:

- » Roboti, letjelice i virtualna stvarnost
- » 3D Experience – Projektiranje broda
- » Infracrvena termografija
- » Čvrstoća konstrukcija
- » Formula Student i Waterbike
- » 3D svijet i konstruiranje
- » Pametne mehatroničke konstrukcije
- » Bazen i ronilica na daljinsko upravljanje
- » Upravljanje mislima
- » Automatika; Mjerna i biomedicinska instrumentacija
- » Solarna elektrana i Trafostanica

U pripremu ovogodišnjeg Job.Fair-a i Dana otvorenih laboratorija uloženo je puno vremena i truda, te nismo propustili trajno zabilježiti atmosferu samih događaja kroz fotografije.

<http://www.riteh.uniri.hr/novosti/jobfair-i-dan-otvorenih-laboratorija-2019-na-tehnickom-fakul/>

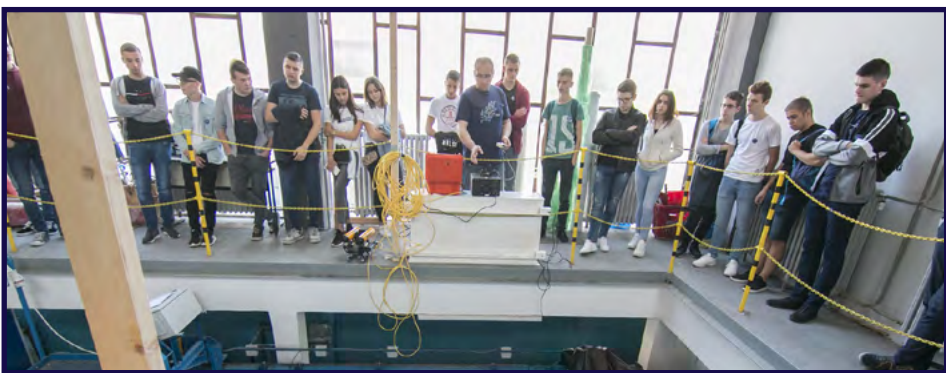

2.6 aktivnosti, zbivanja i konferencije activities, events and conferences

Groups of students alternated in the planned schedule at ten stations - nine laboratories and a joint station where student projects were presented. In addition, after an organized visit to the demonstration sites, students were allowed to subsequently visit any demonstration site and two additional demonstration sites, the Solar Power Plant and the Transformer Station. The following program was implemented:

- » Robots, spacecraft and virtual reality
- » 3D Experience - Ship design
- » Infrared thermography
- » Structural strength
- » Formula Student and Waterbike
- » 3D world and construction
- » Smart mechatronic constructions
- » Pool and submersible remote control
- » Thought management
- » Automation; Measuring and biomedical instrumentation
- » Solar power plant and transformer station

A lot of time and effort was invested in the preparation of this year's Job.Fair and Open Laboratory Day, and we did not fail to permanently record the atmosphere of the events through photographs.

<http://www.riteh.uniri.hr/novosti/jobfair-i-dan-otvorenih-laboratorija-2019-na-tehnickom-fakul/>



2.6 aktivnosti, zbivanja i konferencije activities, events and conferences

## 2.6.4 energetski dani 2019

### energy days 2019



Slijedom višegodišnje uspješne suradnje u obilježavanju županijskog energetskog tjedna, Tehnički fakultet u Rijeci i ove je godine bio partner u realizaciji manifestacije Energetski dani 2019., čiji su inicijatori Primorsko-goranska županija i Regionalna energetska agencija Kvarner.

Ovogodišnji energetski dani nosili su predznak "smart". U kontekstu sve veće prisutnosti koncepta „pametnih gradova“ („Smart Cities“), gradova koji koriste postojeće i napredne tehnologije kako bi pokušali promijeniti načine na koje živimo, putujemo, radimo i koristimo svoje slobodno vrijeme, prisutan je i pojam „pametne energetike“ odnosno pametnih energetskih rješenja za održivi razvoj.

Dana 16. listopada 2019. godine, u suradnji sa Centrom za podršku pametnim i održivim gradovima Sveučilišta u Rijeci, za učenike Prve riječke hrvatske gimnazije održana je interaktivna radionica na temu pametnih energetskih rješenja za razvoj lokalnih zajednica koju su vodili dr. sc. Damir Juričić (UNIRI), Damir Medved (SMART RI), Vedran Kružić (PRIGODA) i Darko Jardas (REA Kvarner).

Sljedećeg dana, 17. listopada 2019. g., u suradnji s Tehničkim fakultetom Sveučilišta u Rijeci, održana je edukacija za studente s ciljem promocije različitih rješenja iz područja razvoja pametnih i samoodrživih otoka, pametnih i energetski učinkovitih zgrada te održivog upravljanje lučkim prometom i zelenom mobilnošću. Stručna izlaganja održali su doc. dr. sc. Vedran Kirinčić (RITEH), Vedran Brajdić (PGŽ) i ravnatelj REA-e Kvarner Darko Jardas sa suradnicima.

Building on the long-lasting good collaboration in organizing the energy week as a regional annual manifestation, the Faculty of Engineering was partner in the realization of the Energy Days 2019 event, initiated by the Primorsko Goranska County and the Institution Regional Energy Agency Kvarner.

This year's energy days were focused on "smart" solutions. In the context of the growing presence of "smart cities" concept - cities that use existing and advanced technologies in order to change the way we live, travel and work - the concept of "smart energy" is also on the rise, presenting smart energy solutions for sustainable development.

On October 16, 2019, in cooperation with the University of Rijeka Centre for support to smart and sustainable cities, an interactive workshop about the usage of smart energy solutions for local development was held for students of the Rijeka's First Croatian High School (PRGH), led by Damir Juričić, PhD (UNIRI), Damir Medved (SMART RI), Vedran Kružić (PRIGODA) and Darko Jardas (REA Kvarner).

The next day, October 17, 2019, in cooperation with the Faculty of Engineering, expert workshop was held for students, with the aim of promoting various solutions in the field of smart and self-sustainable islands, smart energy efficient buildings and sustainable port traffic management and green mobility. Professional presentations were given by Prof. Vedran Kirinčić, PhD (RITEH), Vedran Brajdić (PGC) and the Director of REA Kvarner Darko Jardas with his associates.

Kao popratna aktivnost, na riječkom su lukobranu putem informativnih panoa, od 14.-18. listopada, predstavljene mjere riječkog Plana za niskougljični transport i mobilnost (Low Carbon Transport and Mobility Plan – LCTP) koji je REA Kvarner u okviru europskog projekta LOCATIONS izradila s Lučkom upravom Rijeka, promovirajući široj javnosti rješenja za niskougljični transport u krizerskim destinacijama.

As a side activity, from October, 14 to 18, a panel exhibition was set on the Rijeka breakwater, presenting the measures proposed by the local Low-Carbon Transport Plan (LCTP) that was developed jointly by Rijeka Port Authority and REA Kvarner within the scope of Interreg MED project LOCATIONS, promoting low carbon transport solutions in cruise destination cities.

## ENERGETSKI DANI

### 14.-18. listopada 2019.

u organizaciji

Regionalne energetske agencije Kvarner, Primorsko-goranske županije i Tehničkog fakulteta u Rijeci

**srijeda, 16.10.2019.**

Mjesto događanja: Prva riječka hrvatska gimnazija

11.00 – 12.30 Radionica za učenike

„Pametna energetika u pametnim gradovima – A što ja imam s time?“

Sudjeluju: Darko Jardas - Regionalna energetska agencija Kvarner

Vedran Kružić - Regionalna razvojna agencija Primorsko-goranske županije

Damir Juričić - UNIRI, Centar za podršku pametnim i održivim gradovima

Damir Medved - SMART RI, Centar kompetencija za pametne gradove u Rijeci

**četvrtak, 17.10.2019.**

Mjesto događanja: Tehnički fakultet u Rijeci

12.00 – 14.00 Izlaganja za studente

„Pametna energetika u pametnim gradovima – A što budući RITEH inženjeri imaju s time?“

Sudjeluju: Vedran Kirinčić - Tehnički fakultet u Rijeci

Vedran Brajdić - Primorsko-goranska županija

Darko Jardas, Sanda Hunjak, Vedran Kružić - Regionalna energetska agencija Kvarner

Vedran Kružić - Regionalna razvojna agencija Primorsko-goranske županije

**ponedjeljak, 14.10.2019. – petak, 18.10.2019.**

Mjesto događanja: Informativni panoi na riječkom lukobranu (ispred zgrade putničkog terminala)

Prezentacija mjera predviđenih Planom za nisko-ugljični transport i mobilnost koji su u okviru europskog projekta Interreg MED LOCATIONS zajednički izradile Regionalna energetska agencija Kvarner i Lučka uprava Rijeka.



## 2.6.5 my first conference 2020



Već tradicionalna konferencija za doktorande koji se bave istraživanjima u znanstvenom području Tehničkih znanosti održana je na Tehničkom fakultetu u Rijeci, u zajedničkoj organizaciji s Pomorskim i Građevinskim fakultetom. Na 4th My First Conference, rezultati istraživanja prikazani su kroz objavu knjige sažetaka za 31 rad, a kroz sudjelovanje na konferenciji prezentirano je 28 radova. Iako su radove većinom prijavili doktorandi, na konferenciji je sudjelovao i manji broj perspektivnih diplomanata. Doktorandi su bili aktivni u samoj organizaciji konferencije kroz organizacijski odbor i kroz aktivnosti vođenja pojedinih tematskih cjelina.

Na konferenciji je istaknuta izuzetna aktivnost doktoranada, samoinicijativnost, kreativnost i samostalnost u istraživanjima, svestranost i interdisciplinarnost doktorskih studija, kao i visoka razina njihove kvalitete. Održavanje konferencije omogućilo je doktorandima predstavljanje istraživačkih aktivnosti koje su u tijeku i dobivanje smjernica za buduća istraživanja. S obzirom da je ova konferencija povezala doktorante iz različitih institucija i znanstvenih polja, može se očekivati porast broja kruženja znanstvenika i doktoranada i ostvarenja novih suradnji i interdisciplinarnih istraživačkih projekata.

The already traditional conference for doctoral students whose research is in the scientific field of Engineering Sciences was held at the Faculty of Engineering in Rijeka in joint organization with the Faculty of Maritime Studies and the Faculty of Civil Engineering. At the 4th My First Conference, the results of the research were presented through the publication of a Book of Abstracts for 31 papers, while 28 papers were presented on-site by participating in the conference. Although most papers were submitted by doctoral students, a small number of promising graduates also participated in the conference. The doctoral students were also active in the organization of the conference through the organizing committee and the activities of chairing the thematic sessions.

The conference highlighted the exceptional activities of doctoral students, their self-initiative, creativity and independence in research, and showed that our doctoral students and doctoral studies themselves are very versatile, interdisciplinary and at a high level of quality. It enabled doctoral students to present ongoing research activities and obtain guidelines for future research. Given that this conference brought together doctoral students from different institutions and scientific fields, one can expect an increase in circulation of scientists and doctoral students and the realization of new collaborations and interdisciplinary research projects.



### SEPTEMBER 24, 2020

HOSTED BY: UNIVERSITY OF RIJEKA, FACULTY OF ENGINEERING  
VUKOVARSKA 58, RIJEKA, CROATIA

REGISTER AT: [mfc.uniri.hr](http://mfc.uniri.hr)

ORGANIZED BY: UNIRI



G  
F

## 2.6.6 8. savjetovanje o morskoj tehnologiji 8<sup>th</sup> international conference on marine technology



Osmo Savjetovanje održano je 15. i 16. studenog 2019. godine, kao i dosadašnja, na Tehničkom fakultetu Sveučilišta u Rijeci. Ove je godine uz organizatora, Tehničkog fakulteta Sveučilišta u Rijeci i stalnih suorganizatora, Pomorskog fakulteta Sveučilišta u Rijeci i Udruge za proučavanje i razvoj pomorstva, u organizaciji sudjelovala i međunarodna institucija Fakultet za pomorstvo i promet Sveučilišta u Ljubljani. Uz pojačani međunarodni znanstveni odbor i značajan broj radova stranih autora, savjetovanje je dobilo međunarodni karakter. Pokrovitelj je, već tradicionalno, Hrvatska akademija znanosti i umjetnosti – Razred za tehničke znanosti. Organizacijski odbor Savjetovanja bio je u sastavu: prof. dr. sc. Albert Zamarin, predsjednik, prof. dr. sc. Tomislav Mrakovčić, dopredsjednik, izv. prof. dr. sc. Marko Hadjina, tajnik, prof. emeritus Julijan Dobričić, prof. dr. sc. Zoran Vukić, prof. dr. sc. Jakov Dulčić, izv. prof. dr. sc. Tin Matulja, izv. prof. dr. sc. Lidija Runko Luttenberger, doc. dr. sc. Siniša Vilke, izv. prof. dr. sc. Goran Vukelić, prof. dr. sc. Elen Twrdy i Marko Perčić, mag. ing. mech.

Od prijavljenih 43 sažetka pristiglo je 35 kompletnih radova, s 95 autora i koautora. Dodatno su održana i tri plenarna predavanja i to iz područja: Zakonske regulative kod projektiranja, konstrukcije i upotrebe objekata morske tehnologije, Luksuzne jahte i Onečišćenje zraka sa brodova. Podneseno je 35 priopćenja kroz 6 sekcija

The Eighth Symposium was held on 15 and 16 November 2019, as well as the previous one at the Faculty of Engineering, University of Rijeka. This year, in addition to the permanent organizer, the Faculty of Engineering of the University of Rijeka and permanent co-organizers, the Faculty of Maritime Studies of the University of Rijeka and the Association for the study and development of maritime affairs, the international institution Faculty of Maritime Studies and Transport of the University of Ljubljana participated in the organization. With an enhanced international scientific committee and a considerable number of papers by foreign authors, the conference gained an international character. The symposium was traditionally supported by the Croatian Academy of Sciences and Arts - Department of Engineering Sciences. The Organizing Committee of the Conference was composed of: Prof. D.Sc. Albert Zamarin, chairman, Prof. D. Sc. Tomislav Mrakovčić, vice-chairman, Assoc. Prof. D. Sc. Marko Hadjina, secretary, Prof. Emeritus Julijan Dobričić, Prof. D. Sc. Zoran Vukić, Prof. D. Sc. Jakov Dulčić, Assoc. Prof. Tin Matulja, Assoc. Prof. D. Sc. Lidija Runko Luttenberger, Assist. Prof. Siniša Vilke, Assoc. Prof. Goran Vukelić, Prof. D. Sc. Elen Twrdy, and Marko Perčić, M. Mech. Eng.

Out of 43 abstracts, 35 complete papers were submitted, with 95 authors and co-authors. In addition, three plenary lectures were held in the

**VIII. SAVJETOVANJE O MORSKOJ TEHNOLOGIJI  
in memoriam akademiku Zlatku Winkleru**  
15.-16. studenog 2019.  
na Tehničkom fakultetu Sveučilišta u Rijeci

**8<sup>th</sup> CONFERENCE ON MARINE TECHNOLOGY  
in memoriam of the academician Zlatko Winkler**  
November 15-16, 2019  
at the Faculty of Engineering University of Rijeka

**U organizaciji / Organized by**

Tehnički fakultet Sveučilišta u Rijeci, Hrvatska  
*Faculty of Engineering University of Rijeka, Croatia*

Pomorski fakultet Sveučilišta u Rijeci, Hrvatska  
*Faculty of Maritime Studies University of Rijeka, Croatia*

Fakulteta za pomorstvo in promet, Univerza v Ljubljani, Slovenija  
*Faculty of Maritime Study and Transport, University of Ljubljana, Slovenia*

Udruge za proučavanje i razvoj pomorstva, Rijeka, Hrvatska  
*Association for Research and Development of Maritime Industries, Rijeka, Croatia*



iz područja tehničkih znanosti iz različitih polja i grana, i to: Pomorski transport, konstrukcija i projektiranje u brodogradnji (5), Zaštita okoliša (6), Zakonski okvir, pravila i propisi, standardizacija (3), Pomorske konstrukcije i inženjerstvo (8), Materijali i kemijsko inženjerstvo (4), Autonomna plovila i podvodni inteligentni sustavi (3), Akvakultura i pomorska biologija (2) i Brodostrojarstvo (4). Plenarna predavanja, priopćenja i diskusije su održani na engleskom jeziku, dok je ceremonija otvaranja održana paralelno na hrvatskom i engleskom jeziku.

Savjetovanju je, tijekom dva dana, prisustvovalo više od 100 sudionika, autora, koautora, organizatora, suorganizatora, sponzora, profesora, studenata, privrednika, uzvanika i gostiju.

Recenzirani sažetci priopćenih radova se nalaze na mrežnim stranicama Savjetovanja, a kompletni radovi su, nakon drugog kruga recenzije, objavljeni u specijalnom izdanju časopisa Pomorski zbornik, ISSN 0554-6397, Spec.Vol., 2020.

field of: Regulations for the design, construction and use of marine technology facilities, Luxury yachts and Air pollution from ships. 35 communications were submitted through 6 sections, in the field of engineering sciences from different fields and branches, namely: Maritime transport, construction and design in shipbuilding (5), Environmental protection (6), Legislation, rules, standardization (3), Maritime Structures and Engineering (8), Materials and Chemical Engineering (4), Autonomous Vessels and Underwater Intelligent Systems (3), Aquaculture and Marine Biology (2) and Marine Engineering (4). Plenary lectures, announcements and discussions were held in English, while the opening ceremony was held in parallel in Croatian and English.

The symposium was attended by more than 100 participants, authors, co-authors, organizers, co-organizers, sponsors, professors, students, businessmen and guests.

The reviewed abstracts of the submitted papers are available on the Symposium web pages, and the complete papers, after the second stage of the review process, are published in the special issue of the Journal of Maritime & Transportation Sciences, ISSN 0554-6397, Spec.Vol., 2020.



## 2.6.7 studentski diplomski radovi student graduate theses

IME I PREZIME | NAME AND SURNAME:  
Lovro Radoš

STUDIJSKI PROGRAM | STUDY PROGRAM:  
Diplomski sveučilišni studij brodogradnje  
/ Graduate University Study of Naval Architecture

NAZIV RADA | TITLE:  
**Usporedba klasične metode pokusa nagiba s recentnim alternativnim metodama**  
Comparison Between the Classical Method of Inclining Experiment With The Recent Alternative Methods

MENTOR | SUPERVISOR:  
Doc. dr. sc./ Assist. Prof. D. Sc. Anton Turk

Sažetak:

Klasična metoda pokusa nagibanja koristi se za određivanje položaja težišta broda po visini već dugi niz godina. Metoda sadrži neke osnovne pretpostavke, zbog toga se o točnosti metode raspravlja u zadnjih nekoliko godina. Plovila danas građena imaju zgibove i značajan poprečni nagib dna što može dovesti do značajne promjene vodne linije. Položaj metacentra na ovim se brodovima mijenja kad se nagibaju. Stoga proračun sustava težišta broda po visini klasičnom metodom može biti netočan.

U ovom su radu ispitane tri različite metode koje nisu temeljene na pretpostavci nepromijenjenog metacentra. Primjenom grafičke, polarne i generalizirane metode položaj sustava težišta broda može biti određen za bilo koji brod bez određivanja položaja metacentra. Tri metode spomenute u ovom radu su promatrane i ispitane na četiri različita broda. Uz to, rezultati klasične metode uspoređeni su s dobivenim rezultatima nedavno razvijenih metoda.

Summary:

The classic method of inclining experiments has been used to determine the position of the ship's vertical center of gravity for many years. The method contains some basic assumptions, which is why the accuracy of the method has been debated in the last few years. Vessels built today have folds, a significant transverse slope of the bottom, pronounced bow flare, all of which can lead to a significant change in the waterline. The position of the metacenter changes on these ships as they incline. Therefore, the calculation of the ship's center of gravity system by the classic method may be inaccurate.

In this paper, three different methods that are not based on the assumption of an unchanged metacenter are examined. By applying the graphical, polar, and general methods, the position of the ship's center of gravity system can be determined for any ship without determining the position of the metacenter. The three methods mentioned in this paper were observed and tested on four different ships. In addition, the results of the classic method are compared with the results obtained from recently developed methods.

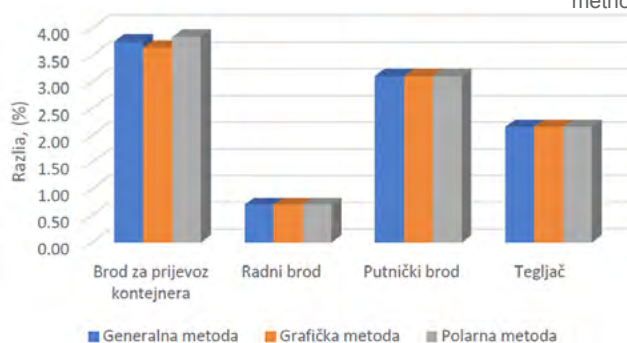

*Usporedba položaja težišta za grafičku, polarnu i generaliziranu metodu*  
/ Center of gravity comparison for graphical, polar, and general methods

IME I PREZIME | NAME AND SURNAME:  
Marko Mavrinac

STUDIJSKI PROGRAM | STUDY PROGRAM:  
Diplomski sveučilišni studij elektrotehnike  
/ Graduate University Study of Electrical Engineering

NAZIV RADA | TITLE:  
**Parametrizacija regulatora primjenom evolucijskih algoritama**  
Regulator Parametrization Using Evolutionary Algorithms

MENTOR | SUPERVISOR:  
Prof. dr. sc. / Prof. D. Sc. Zlatan Car

Sažetak:

Ovaj rad bavi se primjenom genetskog algoritma za problem optimizacije sustava regulacije DC motora s nezavisnom uzбудom po kutu rotora. Teoretski je opisan koncept genetskog algoritma i njegovih elemenata, sustava regulacije koji se optimizira, a uz to je opisana i njihova implementacija u Pythonu, dizajn grafičkog sučelja za prikaz rezultata i sučelja za usporedbu svojstava genetskih algoritama različitih parametara. Uz to, implementirane su određene metode optimizacije uz pomoć kojih se znatno smanjuje vrijeme izvođenja algoritma, a izvršena je usporedba rezultata u MATLAB-u odnosno Simulinku kako bi se utvrdila vjerodostojnost matematičkog modela u Pythonu kao i vjerodostojnost rezultata optimizacije. Kako bi se utvrdio idealan skup parametara za rješenje problema optimizacije navedenog sustava regulacije, izvršena je usporedba genetskih algoritama bazirana na veličini populacije, vjerojatnosti mutacije, relativnoj toleranciji ocjene podobnosti i različitim metodama selekcije.

Summary:

This paper analyzes the application of genetic algorithm for the purpose of optimizing a control system with separately excited DC motor controlled according to the rotor angle. The theoretical concept of genetic algorithm and its elements has been described along with the concept of the control system being optimized. Also, Python implementation of the genetic algorithm, mathematical model of the control system, graphical user interface for result analysis and interface for genetic algorithm comparison have been described. Certain optimization methods used for noticeable execution time reduction have been implemented and a comparison has been made between MATLAB and Python model simulation results to ensure credibility of optimization results given by the genetic algorithm. In order to determine an ideal set of parameters for this particular optimization problem, a comparison has been made between genetic algorithms based on population size, mutation probability, relative fitness score tolerance and different selection methods.

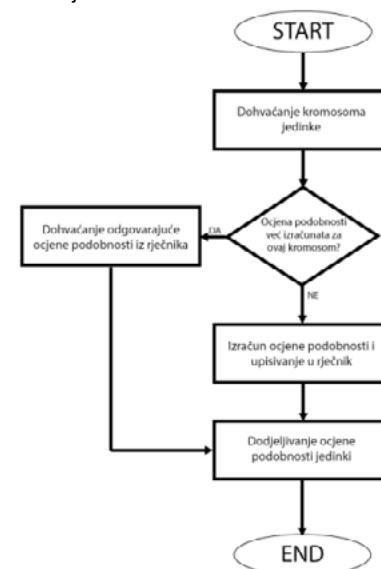

*Dijagram toka optimizirane funkcije podobnosti*  
/ Flow diagram of the optimized function fitness

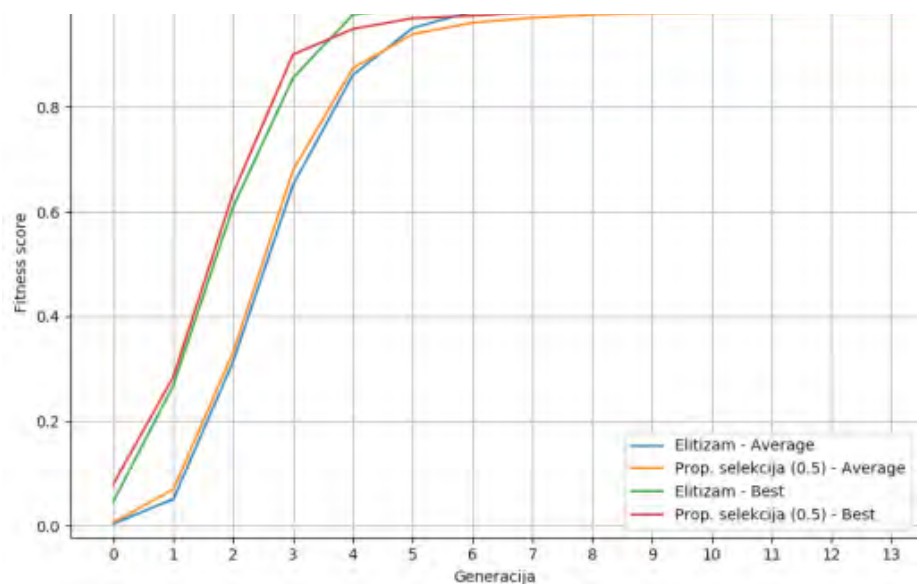

Usporedba genetskog algoritma sa selekcijom proporcionalnom funkciji podobnosti i elitističkom selekcijom

/ Comparison of the genetic algorithm with selection proportional to fitness function and elitist selection

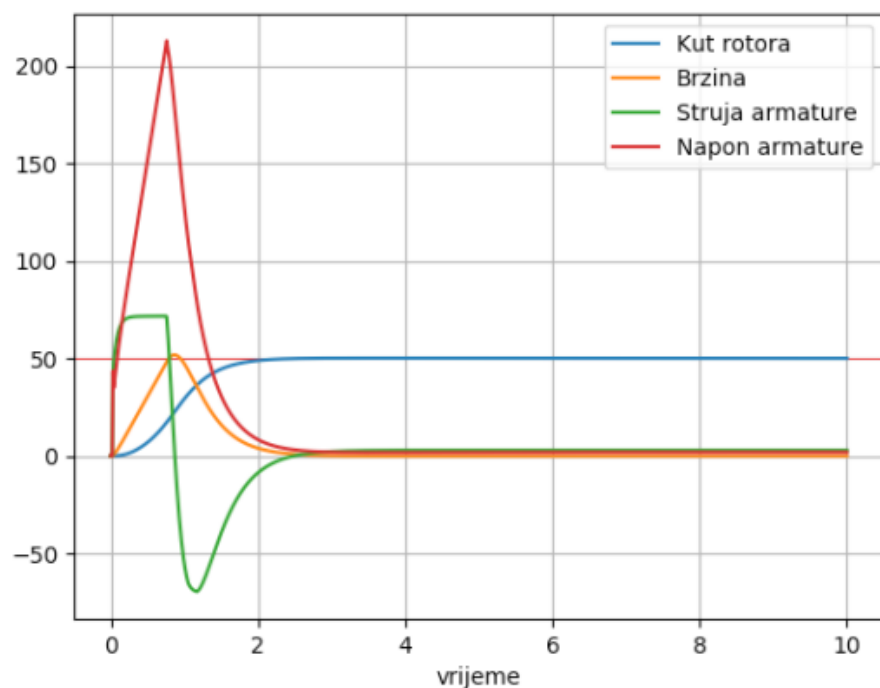

Odziv regulacijskog sustava optimiziranog genetskim algoritmom

/ The response of a control system optimized by a genetic algorithm

IME I PREZIME | NAME AND SURNAME:

Dorjan Vukelić

STUDIJSKI PROGRAM | STUDY PROGRAM:

Diplomski sveučilišni studij elektrotehnike

/ Graduate University Study of Electrical Engineering

NAZIV RADA | TITLE:

**Detekcija atmosferskih pojava metodama umjetne inteligencije**

Detection of Atmospheric Phenomena Using Artificial Intelligence

MENTOR | SUPERVISOR:

Prof. dr. sc. / Prof. D. Sc. Zlatan Car

Sažetak:

Summary:

U ovom radu, metodama umjetne inteligencije, ispitivala se mogućnost detekcija atmosferskih pojava „sprite“, gotovo nevidljivih golim okom. Pojava „sprite“ označava atmosfersko-elektrostatičku pojavu koja putuje u obrnutom smjeru (od zemlje na gore) od klasičnih munja. Prvi dio rada sastojao se od analize i obrade snimki i izradu sustava za učitavanje snimaka dostavljenih u FITS (Flexible Image Transport System) formatu koji daju mogućnost spremanja različitih oblika snimaka u jednoj datoteci. Snimke su ustupljene od Globalne Meteorske Mreže (GMN), a dostavljeno je 500 snimaka pojave Sprite i 500 snimaka na kojima iste pojave nema. Za klasifikaciju u slike na kojima se nalazi tražena pojava i slike bez nje korištena je konvolucijska neuralna mreža (eng. Convolutional Neural Network – CNN), a kao dio rada podešavani su njeni parametri sa ciljem smanjenja pogreške klasifikacije. Za procjenu kvalitete klasifikacije korištene su metrike točnosti, AUC i F1. Radi ispitivanja stabilnosti dobivenih klasifikacijskih modela korištena je K-fold validacija sa 10 preklapanja. Na samom kraju rada prikazani su rezultati i vrijeme treniranja mreže pod određenim parametrima. Postignuti rezultati su zadovoljavajući, sa točnošću klasifikacije iznad 95% i AUC i F1 metrikama od 0.9849 i 0.9885.

This paper explores the possibility of using artificial intelligence methods in detection of the so called „sprite“ phenomena which are invisible to the human eye. Sprite phenomenon describes the atmospheric electrostatic charge release which travels in a different direction (from the ground up) from the classical lightning. The first part of the paper consists of analysis and processing of delivered images, as well as developing a system for loading the FITS (Flexible Image Transport System) formatted images, which provide the possibility of storing multiple data images within a single file. The data was provided by Global Meteor Network (GMN), and consists of 500 sprite images and 500 images without the phenomena present. For classification the Convolutional Neural Network is used, and its parameters are adjusted as part of the paper in order to lower the model error. Assessment of models is done using Accuracy, AUC and F1 metrics. To test the stability of the obtained models K-fold validation with 10 folds is used. Results and training times are presented at the end of this paper. The obtained results are satisfactory, with accuracy of the model being above 95%, with AUC and F1 metrics of 0.9849 and 0.9885.



Slika noćnog neba uz detalj pojave „sprite“ označen crvenim krugom. Izvor: Global Meteor Network  
/ Picture of the night sky with a detail of the appearance of „sprite“ marked with a red circle. Source: Global Meteor Network

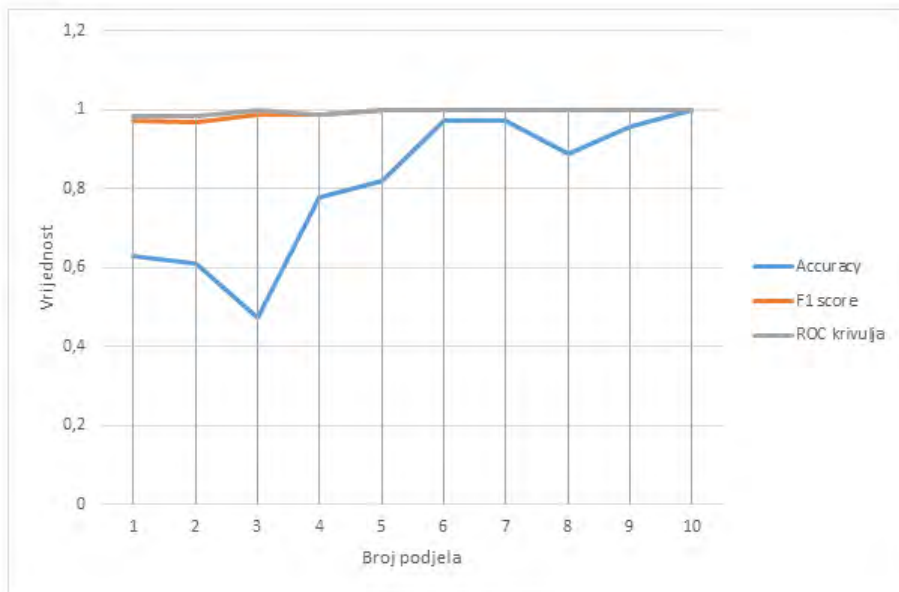

Rezultati mreže kod treniranja sa 10 podjela i 500 epoha / Network results in training with 10 divisions and 500 epochs

IME I PREZIME | NAME AND SURNAME:  
Ivana Žužić

STUDIJSKI PROGRAM | STUDY PROGRAM:  
Diplomski sveučilišni studij računarstva  
/ Graduate University Study of Computing

NAZIV RADA | TITLE:  
**Generativne suparničke mreže za dodavanje i uklanjanje gipsa s rtg slika ruke**  
Generative Adversarial Networks for Adding And Removing Casts From Hand X-Ray Images

MENTOR | SUPERVISOR:  
Izv. prof. dr. sc. / Assoc. Prof. D. Sc. Ivan Štajduhar

Sažetak: Summary:

Ovaj diplomski rad daje pregled korištenja generativnih suparničkih mreža u području slika za medicinsku dijagnostiku i nudi metodu dodavanja i micanja gipsa s RTG-slika ruku pomoću CycleGAN-a. Cilj rada je pridonijeti ubrzanju dijagnoze pacijenata, treniranju radiologa i proširivanju postojećih skupova podataka radioloških slika.

Korištena metoda strojnog učenja, CycleGAN pripada tehnikama nenadziranog učenja. Primjenjuje se za translaciju slike iz izvorišne domene u ishodišnu domenu i obratno. Pritom se uče dva mapiranja koja čine ciklus po kojem je CycleGAN dobio ime. Prvo mapiranje pretvara sliku s gipsom u sliku bez gipsa, a drugo pretvara sliku bez gipsa u sliku s gipsom. Za implementaciju

This thesis gives an overview of generative adversarial networks usage in the field of medical diagnostic imaging and offers a method of adding and removing cast from X-ray images of hands using CycleGAN. The goal of the thesis is to contribute to shortening the diagnosis time for patients, training radiologists and increasing the size of the existing radiologic images datasets.

The method that has been used, CycleGAN, belongs to unsupervised learning techniques. It's used for translating images from the source domain to the destination domain and vice versa. Two mappings are learned during the training and they form a cycle that has given the name to CycleGAN. The first mapping turns an image with cast into an image without cast

modela korišten je PyTorch. Za treniranje modela korišten je skup pedijatrijskih radioloških slika ruke iz bolnice u Grazu.

Nekoliko CycleGAN modela s razlikama u arhitekturi i veličini ulazne slike isprobani su i uspoređeni prema postignutoj distribuciji boja i procijenjeni od strane iskusnog radiologa. Rezultati su pokazali da je CycleGAN koji koristi U-Net za stvaranje slika veličine 512x512 najkorisniji za radiologa i ima najbližu distribuciju boja originalnoj distribuciji.

and the second turns an image without cast into an image with cast. PyTorch has been used to implement the models. A dataset of pediatric radiological images of hands from the hospital in Graz has been used for training the models.

Multiple CycleGAN models with architectural differences have been tried out and their performance has been compared in terms of achieved colour distribution and evaluated by an experienced radiologist. The results show that the CycleGAN using U-Net for 512x512 images generation is the most useful for the radiologist and has the closest colour distribution to the original one.

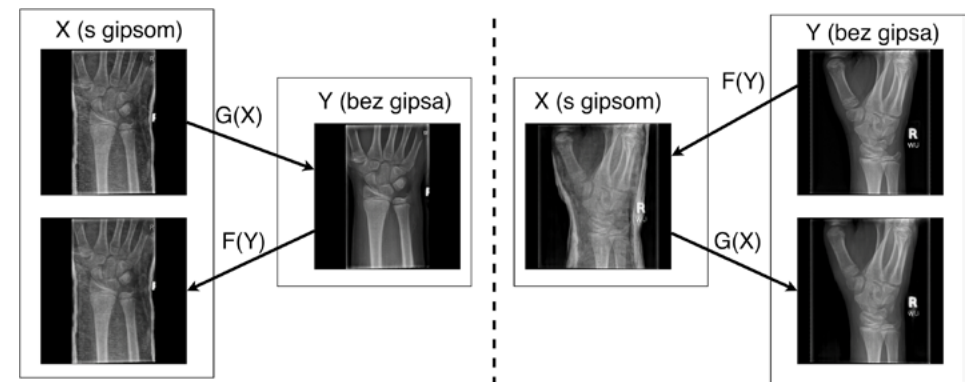

Primjer kruženja slike kroz CycleGAN: slika s gipsom (lijevo) i slika bez gipsa (desno) / An example of an image going through the CycleGAN: an image with cast (left) and an image without cast (right)



Usporedba pravih slika s gipsom (lijevi stupac) i slika s gipsom koje su umjetno stvorene CycleGAN-om (desni stupac) / Comparison of the real images with cast from the dataset (left column) and the artificial images with cast created with CycleGAN (right column)

IME I PREZIME | NAME AND SURNAME:

Marko Njirjak

STUDIJSKI PROGRAM | STUDY PROGRAM:

Diplomski sveučilišni studij računarstva  
/ Graduate University Study of Computing

NAZIV RADA | TITLE:

**Detekcija potresa korištenjem vremensko-frekvencijskih predstava seizmograma**

Earthquake Detection Using Seismogram Time-Frequency Representations

MENTORI | SUPERVISORS:

Izv. prof. dr. sc. / Assoc. Prof. D. Sc. Ivan Štajduhar

Doc. dr. sc. / Assist. Prof. D. Sc. Jonatan Lerga

Sažetak:

Ovaj se rad pozabavio idejom kako različite vremensko-frekvencijske predstave seizmogramskih podataka mogu imati značajan utjecaj na točnost detekcije potresa korištenjem konvolucijskih neuronskih mreža. Korištene su devet vremensko-frekvencijskih transformacija i tri afirmirane konvolucijske neuronske mreže (VGG16, AlexNet i Resnet50). Originalni podaci seizmograma najprije su obrađeni transformacijama te su korišteni za treniranje neuronskih mreža. Također, originalni podaci iskorišteni su za treniranje zasebnog, nekonvolucijskog modela koji je poslužio kao kontrolni element u eksperimentu. Rezultati pokazuju da kombinacija pseudo Wigner-Ville vremensko-frekvencijske distribucije i AlexNet arhitekture poboljšava rezultate baznog modela za 1,56 postotnih bodova. Navedeno može imati značajan odjek u području seizmologije s obzirom na činjenicu da se točnije klasificiraju podaci koji su do tada bili skriveni u seizmološkom šumu. Uz to, pokazano je da vremensko-frekvencijska distribucija spektrograma, često primjenjivana u seizmologiji, ima daleko najlošije rezultate.

Summary:

This paper addresses the idea that different time-frequency representations of seismogram data can have a significant impact on the accuracy of earthquake detection using convolutional neural networks. Nine time-frequency transformations and three well-established convolutional neural networks have been used (VGG16, AlexNet and Resnet50). Firstly, the original seismogram data have been processed by transformations and used for neural network training. Moreover, the original data have been used to train a separate, nonconvolutional model that served as a control element in the experiment. The results show that the combination of the pseudo Wigner-Ville time-frequency distribution and the AlexNet architecture improves the results of the base model by 1.56 percentage points. This can have a significant impact in the field of seismology due to the fact that the data previously hidden in the seismological noise are now classified more accurately. In addition, the time-frequency distribution spectrogram, often used in seismology, has been shown to yield by far the worst results.

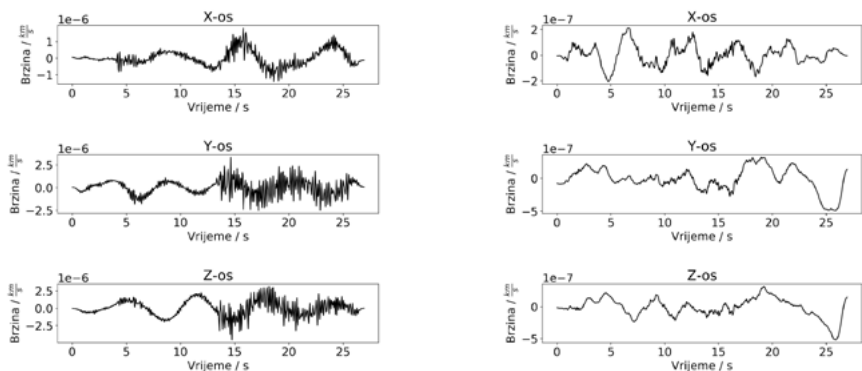

Dva nasumično uzorkovana seizmograma iz skupa podataka LEN-DB, potres (lijevo) i šum (desno)  
/ Two randomly sampled seismogram instances from LEN-DB dataset, depicting earthquake (left) and noise (right)

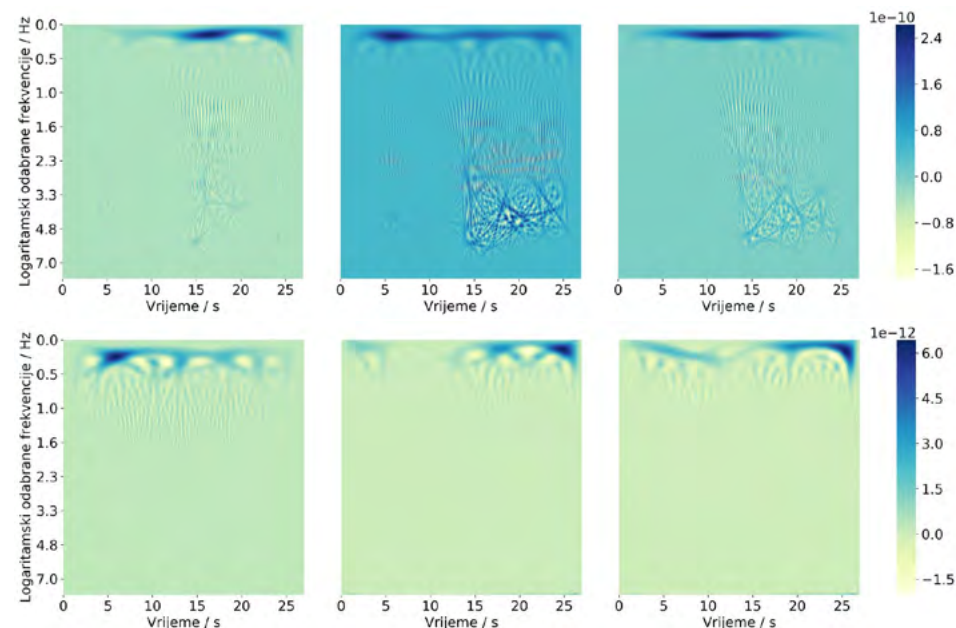

Prikaz pseudo Wigner-Ville transformacija potresa (gore) i šuma (dolje)  
/ Pseudo Wigner-Ville transformations of earthquake (up) and noise (down)

	VGG16	Resnet50	AlexNet
bj	94,69%	94,52%	94,28%
bud	93,86%	93,39%	92,41%
cw	92,68%	93,03%	93,75%
mh	86,45%	88,70%	88,79%
pwv	95,11%	95,57%	95,71%
ridb	94,94%	95,00%	94,47%
sp	56,46%	95,00%	68,77%
spwv	93,21%	93,79%	90,34%
wv	94,90%	95,24%	94,72%
bazni model	94,15%		

Rezultati evaluacije modela korištenjem klasifikacijske točnosti izmjerene na testnom skupu podataka  
/ Results of model evaluation using classification accuracy measured on a test dataset

IME I PREZIME | NAME AND SURNAME:

Erik Otović

STUDIJSKI PROGRAM | STUDY PROGRAM:

Diplomski sveučilišni studij računarstva  
/ Graduate University Study of Computing

NAZIV RADA | TITLE:

**Učenje prijenosom znanja iz vremenskih serija – u kojoj su mjeri značajke prenosive?**

Transfer Learning In Time Series Data – How Transferable Are The Features?

MENTOR | SUPERVISOR:

Izv. prof. dr. sc. / Assoc. Prof. D. Sc. Ivan Štajduhar

Sažetak:

Ovaj rad se fokusira na usporedbu performansi modela strojnog učenja koji su trenirani prijenosom znanja i onih koji nisu, a sve to u okviru vremenskih serija. Sustavno se promatra i analizira točnost odabranih modela prilikom prelaska unutar iste domene primjene (seizmologija), ali i između međusobno različitih domena primjene (seizmologija, govor i zvuk, medicina, financije). Modeli su trenirani na malenim skupovima podataka veličina 1500 i 9000 primjeraka kako bi se simulirali stvarni uvjeti u kojima je vrlo zahtjevno ili nemoguće prikupiti dovoljno veliku količinu označenih podataka. Problemi iz područja seizmologije i financija su regresijske prirode, dok su problemi iz područja govora i medicine klasifikacijske prirode. Za eksperiment su korištena četiri modela strojnog učenja. Od toga, dva modela su preuzeta iz područja seizmologije, a ostala dva su modeli opće namjene za rad s vremenskim serijama. Kako bi se valjanost dobivenih rezultata potvrdila, primijenjeni su određeni statistički testovi.

Kroz rad je pokazano kako je unutar postavljenih eksperimentalnih okvira prijenos znanja donio poboljšanje u performansama modela i brzini konvergencije prilikom treniranja. Prijenos znanja je primarno donio značajna poboljšanja u vidu točnosti modela, a sekundarno u vidu brzine konvergencije modela. U nekoliko problematičnih i rubnih slučajeva su provedena dodatna ispitivanja sa ciljem obrazlaganja neočekivanih rezultata. Uzimajući u obzir sve rezultate, pokušao se ponuditi odgovor na temeljna pitanja prilikom prijenosa znanja: što prenijeti, kako prenijeti i kada prenijeti. U konačnici, rad nudi zaključak kada je učenje prijenosom znanja korisno, a ponuđena obrazloženja mogu pružiti dobru polazišnu točku za prijenos znanja u području vremenskih serija.

Summary:

This paper focuses on comparing the performance of machine learning models that are trained using transfer learning and those that are not, all in the context of time series. The accuracy of selected models is systematically observed and analyzed when switching within the same domain of application (seismology), but also between mutually different domains of application (seismology, speech and sound, medicine, finance). The models have been trained on small datasets of 1,500 and 9,000 copies to simulate real conditions in which it is very demanding or impossible to collect a large enough amount of tagged data. Problems in the field of seismology and finance are regressive in nature, while problems in the field of speech and medicine are of classificational nature. Four machine learning models have been used for the experiment. Of these, two models have been taken from the field of seismology, and the other two have been general-purpose models for working with time series data. In order to confirm the validity of the obtained results, certain statistical tests have been applied.

The paper shows how, within the set experimental framework, the transfer of knowledge has brought an improvement in the model performance and the speed of convergence during training. Knowledge transfer has brought primary improvements in terms of model accuracy, and secondarily in terms of model convergence rate. In several problematic and marginal cases, additional tests have been conducted to explain the unexpected results. Taking into account all the results, an attempt has been made to offer answers to the basic questions when transferring knowledge: "What to transfer?", "How to transfer?" and "When to transfer?". Ultimately, the paper offers a conclusion when transfer learning is useful, and the explanations offered can provide a good starting point for knowledge transfer in the field of time series.

IME I PREZIME | NAME AND SURNAME:

Matea Ignatoski

STUDIJSKI PROGRAM | STUDY PROGRAM:

Diplomski sveučilišni studij računarstva  
/ Graduate University Study of Computing

NAZIV RADA | TITLE:

**Usporedba algoritama za kompresiju teksta na različitim jezicima**

Comparison of Algorithms for Text Compression in Various Languages

MENTOR | SUPERVISOR:

Doc. dr. sc. / Assist. Prof. D. Sc. Jonatan Lerga

Sažetak:

Nagli rast količine podataka u digitalnom svijetu vodi do potrebe za kompresijom podataka. Kompresija podataka je proces smanjenja broja bitova potrebnih za predstavljanje tekstualne datoteke, slike, audio ili video sadržaja. Na taj način smanjuje se potreba za većim kapacitetima za pohranu podataka i ubrzava se proces prijenosa podataka. U ovome radu fokusiramo se na kompresiju teksta i proučavamo algoritme (aritmetičko kodiranje i LZW kodiranje) i njihovu učinkovitost u kompresiji tekstova na različitim jezicima (hrvatski, češki, talijanski, francuski, njemački i engleski).

Glavni cilj rada je odgovoriti na pitanje utječe li jezik teksta na omjer kompresije. Rezultati su pokazali kako omjer kompresije ovisi o broju slova abecede i gramatici jezika te o duljini i tipu teksta. Na primjer, engleska, njemačka, francuska, talijanska, češka i hrvatska verzija teksta "Europski zeleni plan" su redom komprimirane za 75.79 %, 76.17 %, 77.33 %, 76.84 %, 73.25 % i 74.51 % LZW kodiranjem te za 72.54 %, 71.47 %, 72.87 %, 73.43 %, 69.62 % i 72 % aritmetičkim kodiranjem.

Summary:

The rapid growth in the amount of data in the digital world leads to the need for data compression, i.e., reducing the number of bits needed to represent a text file, an image, audio, or video content. Compressing data saves storage capacity and speeds up data transmission. In this paper, we focus on the text compression and provide a comparison of algorithms (in particular, arithmetic and Lempel–Ziv–Welch (LZW) methods) for text compression in different languages (Croatian, Czech, Italian, French, German, and English).

The main goal is to answer the following question: "How does the language of a text affect the compression ratio?" The results indicate that the compression ratio is affected by the size of the language alphabet, the grammar and size or type of the text. For example, The European Green Deal has been compressed by 75.79%, 76.17%, 77.33%, 76.84%, 73.25%, and 74.51% using the LZW algorithm, and by 72.54%, 71.47%, 72.87%, 73.43%, 69.62%, and 72% using the arithmetic algorithm for the English, German, French, Italian, Czech and Croatian versions, respectively.

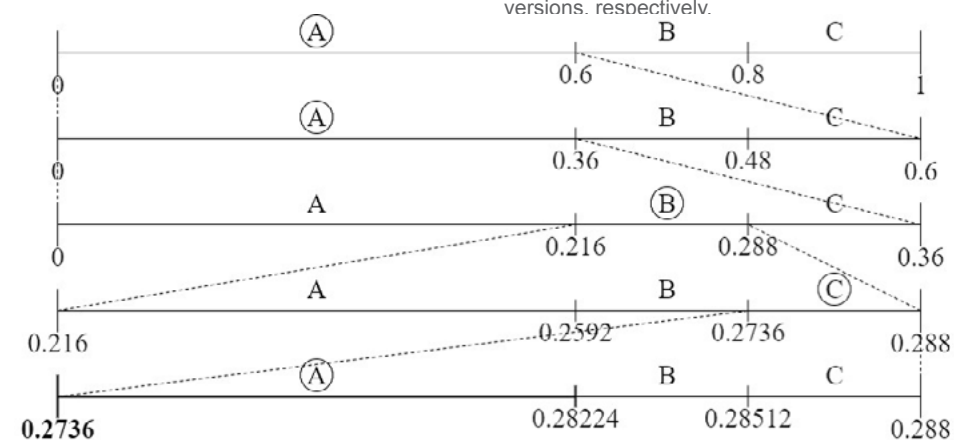

Primjer aritmetičkog kodiranja  
/ An example of arithmetic coding

s a m o u p r a v n o p r a v n i	w x	Encoded message	Dictionary (index)
*	s a	115	sa (257)
	a m	97	am (258)
	m o	109	mo (259)
	o u	111	ou (260)
	u p	117	up (261)
	p r	112	pr (262)
	r a	114	ra (263)
	a v	97	av (264)
	v n	118	vn (265)
	n o	110	no (266)
	o p	111	op (267)
	p r		
	pr a	262	pra (268)
	a v		
	av n	264	avn (264)
	n i	110	ni (265)
	i end	105	ni (265)
	end	256	

Primjer LZW kodiranja / An example of LZW coding

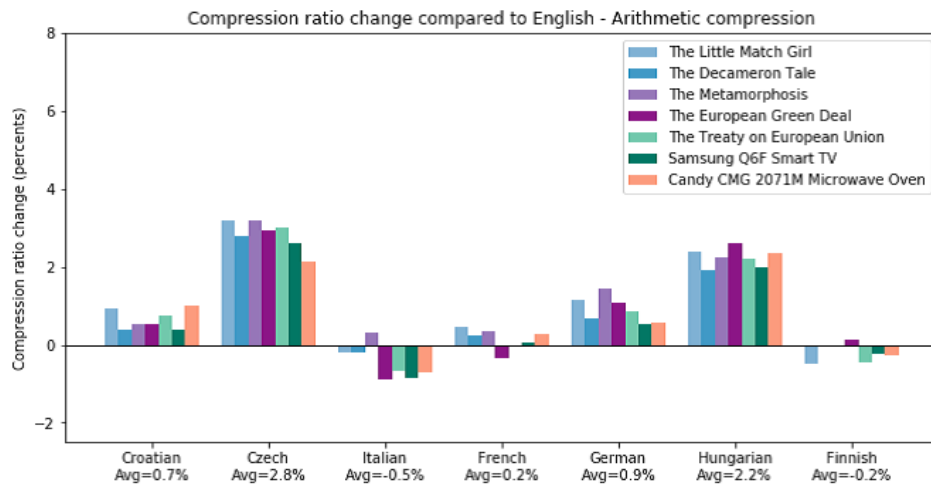

Usporedba engleskog i drugih jezika za aritmetičko kodiranje / Comparison of English and other languages for arithmetic coding

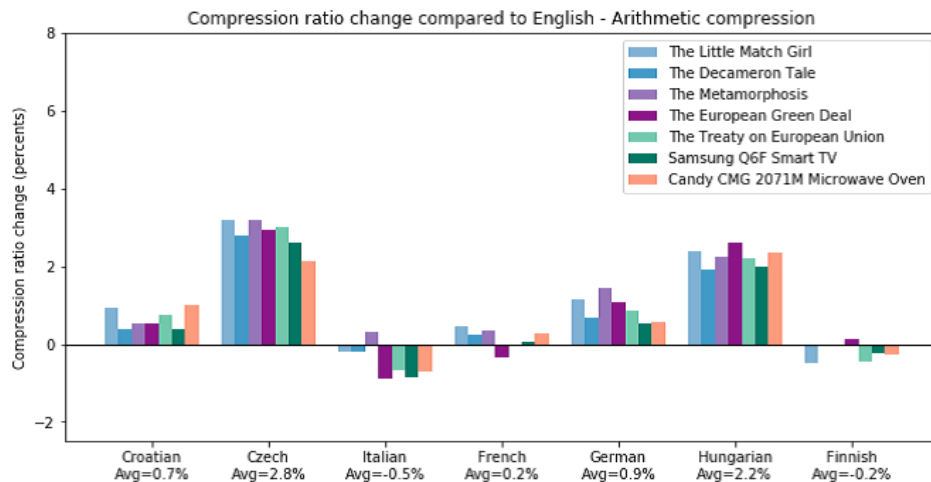

Usporedba engleskog i drugih jezika za LZW kodiranje / Comparison of English and other languages for LZW coding

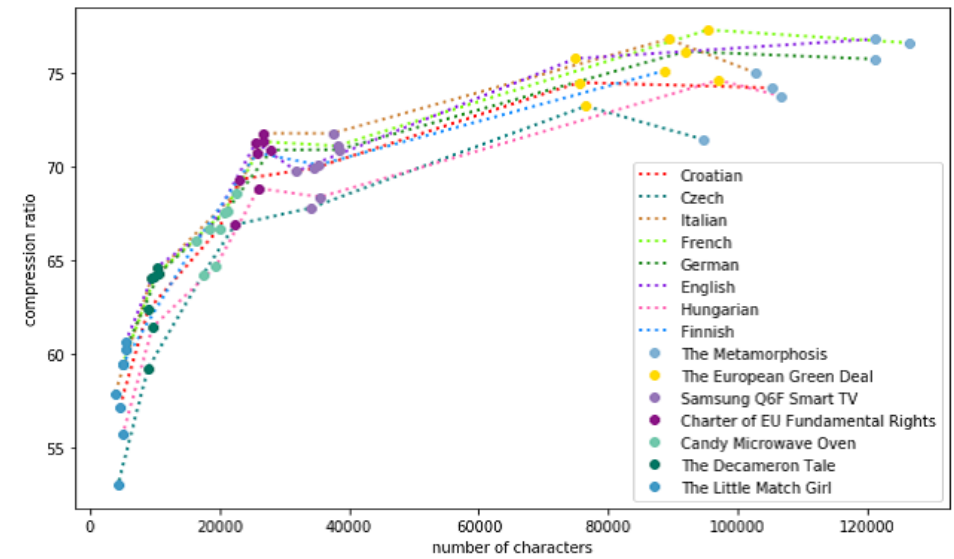

Rezultati kompresije za LZW kodiranje u ovisnosti o duljini teksta / Compression results for LZW coding with respect to text length

IME I PREZIME | NAME AND SURNAME:  
Ema Miletić

STUDIJSKI PROGRAM | STUDY PROGRAM:  
Diplomski sveučilišni studij računarstva / Graduate University Study of Computing

NAZIV RADA | TITLE:  
**Vrste i svojstva qr i sličnih naprednijih kodova**  
Types and Properties of QR and Similar Advanced Codes

MENTOR | SUPERVISOR:  
Doc. dr. sc. / Assist. Prof. D. Sc. Jonatan Lerga

Sažetak: Summary:

QR kod je vrsta dvodimenzionalnog koda koji je danas u širokoj upotrebi zahvaljujući značajkama poput velikog kapaciteta pohrane podataka, jednostavnosti očitavanja, pouzdanosti i male površine koda. Kod se sastoji od crnih i bijelih polja kvadratnog oblika koji se nazivaju moduli. Moduli tvore funkcijske uzorke u kodu te dio koda za pohranu podataka. U radu su opisane struktura QR koda, njegove karakteristike i postupci generiranja i očitavanja koda. Postoji više vrsta QR koda koje se razlikuju veličinom, izgledom i namjenom, a koje su nastale kao prilagodba raznolikim potrebama korisnika. Iako se QR kod odlikuje velikim kapacitetom pohrane podataka, neprestano se teži daljnjem povećanju kapaciteta. U ovome su radu opisani načini povećanja kapaciteta QR koda pomoću primjene boja i kompresije podataka. Također, ukratko je opisano nekoliko metoda spajanja QR koda sa

The QR code is a type of two-dimensional code which is nowadays in wide use because of its features such as a large data storing capacity, ease of use, reliability and small surface area of the code. The code is made up of black and white squares which are referred to as modules. The modules are arranged so that they create function patterns and an area of code used for data storage. This paper describes the structure of QR code, its characteristics and the processes of code generation and decoding. There are many forms of QR codes which differ in size, appearance and purpose. Those have been created as a result of the users' different needs. Even though the QR code has a large storage capacity, there is an ongoing search for new effective ways to improve its capacity. In this paper, ways to increase the QR code capacity involving the introduction of color into the code

slikama u svrhu povećanja vizualne privlačnosti koda. Naposljetku, rad se osvrće na ostale dvo-dimenzionalne kodove slične QR kodu, kao što su primjerice Data matrix kod i Dot kod.

and data compression are described. The paper also briefly reviews the methods for merging pictures into the QR code with the purpose of adding visual interest to the code. Finally, the paper deals with other two-dimensional codes similar to the QR code, such as Data matrix and Dot code.

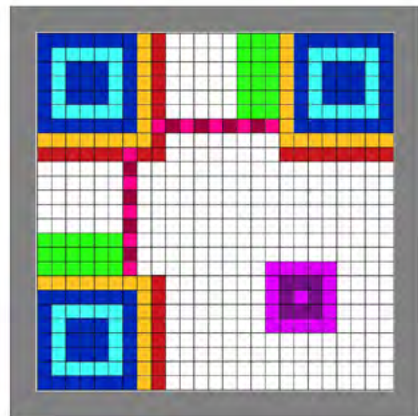

Komponente QR koda  
/ Components of QR code

**Funkcionalni uzorci:**

- Separatori
- Uzorci za pronalaženje
- Uzorci za tempiranje
- Uzorci za poravnavanje

**Područje za kodiranje:**

- Podaci i kodne riječi za ispravak pogrešaka
- Informacije o verziji
- Informacije o formatu

■ Tiha zona

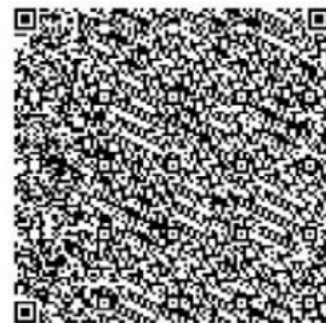

Verzija 40  
(177x177)



Verzije QR koda  
/ Versions of QR code

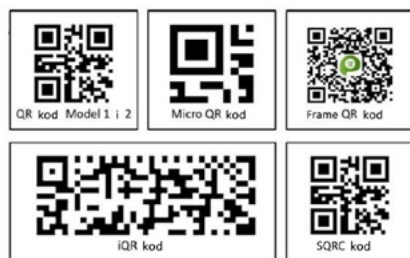

Tipovi QR koda  
/ Types of QR code

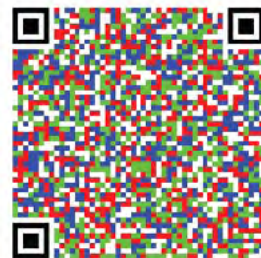

Primjer QR koda u boji  
/ An example of color QR code



Primjeri: Frame QR, Visualead kod, QArt kod, Halftone kod, QR Image kod, PiCode, Semacode, Maxi kod, Aztec kod, Dot kod, PDF417 kod, VeriCode, VSCode  
/ Examples of Frame QR code, Visualead code, QArt code, Halftone code, QR image code, PiCode, Semacode, Maxi code, Aztec code, Dot code, PDF417 code, VeriCode, VSCode

IME I PREZIME | NAME AND SURNAME:  
Alen Guštin

STUDIJSKI PROGRAM | STUDY PROGRAM:  
Diplomski sveučilišni studij strojarstva  
/ Graduate University Study of Mechanical Engineering

NAZIV RADA | TITLE:  
**Razvoj naplatka od ugljičnih vlakana za bolid formule student**  
Development of Carbon Fibre Rim for Formula Student Car

MENTOR | SUPERVISOR:  
Prof. dr. sc. / Prof. D. Sc. Sanjin Braut

Sažetak:

Summary:

U ovom radu prikazana je provedba postupka konstruiranja naplatka od ugljičnih vlakana za bolid Formule Student. Opterećenja na naplatak izračunata su na temelju podataka o bolidu Riteh Racing Teama RRC6. Dobivena su tri kritična stanja opterećenja: maksimalno opterećenje u zavoju, opterećenje pri maksimalnom kočenju i opterećenje pri udaru u izbočinu. Izračunata opterećenja korištena su u izračunu faktora si-

This paper shows the process of designing a carbon fiber wheel rim for a Formula Student vehicle. Loads have been calculated based on the data received from Riteh Racing Team's RRC6 race car. Three critical load cases have been identified: maximum load while taking a curve, maximum braking load and impact load from a bump. The calculated load cases have been used to calculate the factor of safety of a



gurnosti komercijalno dostupnog aluminijskog naplatka metodom konačnih elemenata. Prikazane su specifičnosti svojstava i izrade dijelova od plastike, pojačane ugljičnim vlaknima. Na temelju toga izrađen je model naplatka od ugljičnih vlakana. Model je dimenzioniran i optimiziran korištenjem metode konačnih elemenata. Nakon provođenja iteracijskog postupka na geometriji i layupu konstruiranog naplatka, postignuto je smanjenje mase od 26,4 % u odnosu na ekvivalentni naplatka od magnezijeve legure, uz očuvanje jednake krutosti. Za finalni model izračunat je utjecaj deformacije naplatka na postavke ovjesa vozila.

commercially available aluminum rim using the finite element method. The unique characteristics of performance and manufacturing of carbon fiber reinforced plastics have been presented. Based on this, a model of a carbon fiber reinforced wheel rim has been made. The model was dimensioned and optimized using the finite element method. After performing the iterative procedure on the geometry and composite layup of the constructed rim, a weight reduction of 26.4% compared to the equivalent magnesium alloy rim has been achieved while maintaining the same stiffness. The influence of the final rim design on suspension settings of the vehicle has been calculated.

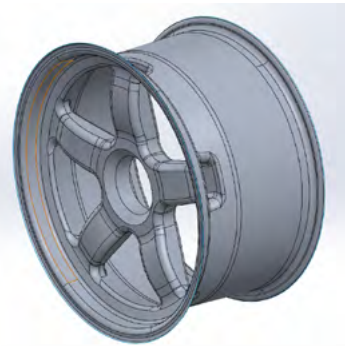

Finalna iteracija geometrije naplatka  
/ Final iteration of the geometry of the rim

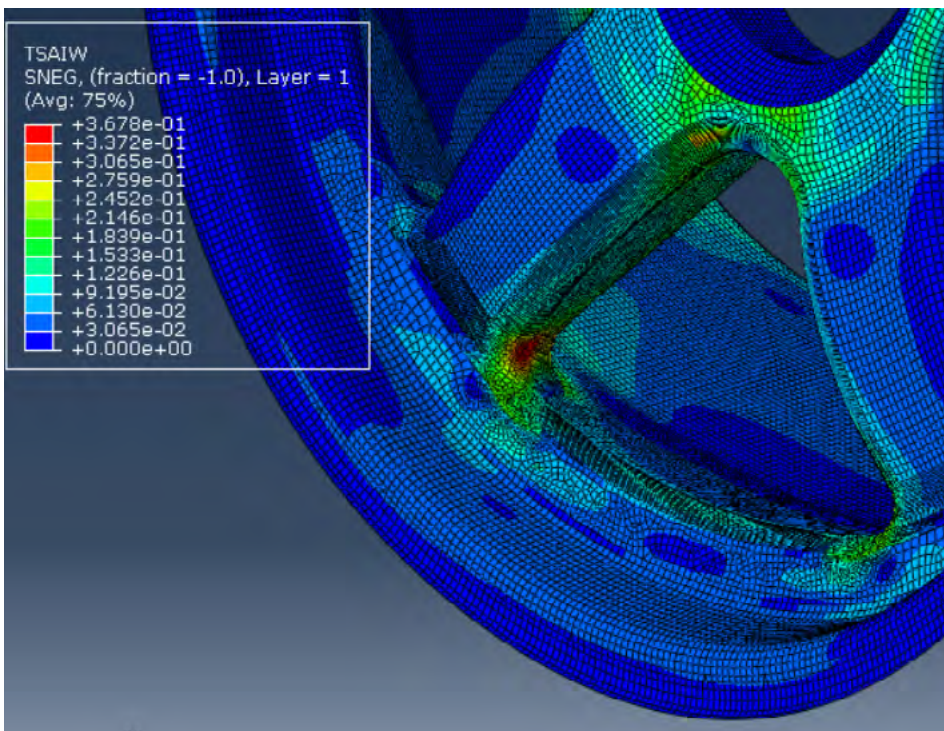

Maksimalno naprezanje finalnog naplatka pri udaru u izbočenje  
/ Maximum stress of the final rim at impact load from a bump

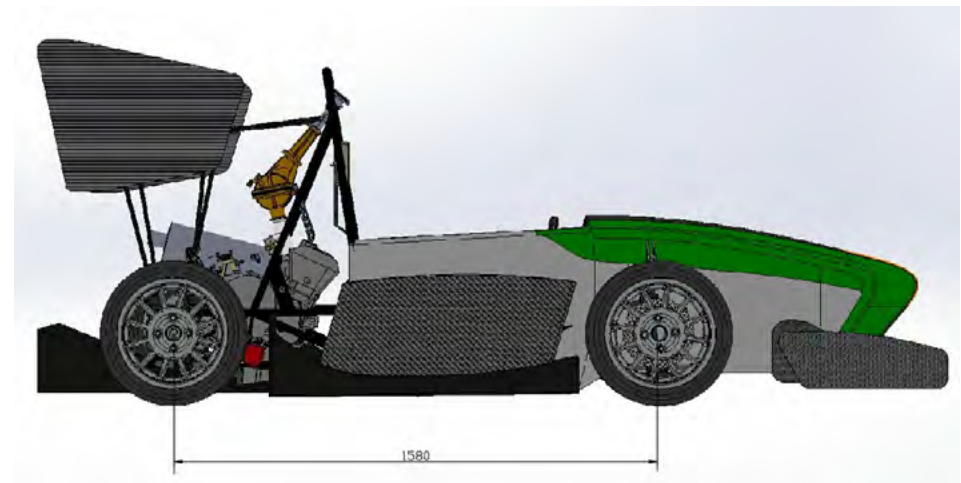

Međuosovinski razmak novog bolida Riteh Racing Teama RRC6  
/ Wheelbase spacing of the new Riteh Racing Team RRC6 car

IME I PREZIME | NAME AND SURNAME:  
Tihomir Gašpar-Fernežir

STUDIJSKI PROGRAM | STUDY PROGRAM:  
Diplomski sveučilišni studij strojarstva  
/ Graduate University Study of Mechanical Engineering

NAZIV RADA | TITLE:  
**Numerička i eksperimentalna analiza karakteristika polimernih materijala u uvjetima puzanja**  
Numerical and Experimental Analysis of The Characteristics Of Polymeric Materials in Creep Conditions

MENTOR | SUPERVISOR:  
Izv. prof. dr. sc. / Assoc. Prof. D. Sc. Marino Brčić

Sažetak:

Summary:

Ciljevi ovog rada bila su eksperimentalna ispitivanja mehaničkih karakteristika zadanih polimernih materijala u uvjetima jednoosnog vlačnog opterećenja i u uvjetima kratkotrajnog puzanja. Ispitani polimerni materijali su polilaktidna kiselina (PLA), akrilonitril butadien stiren (ABS) i akrilonitril stiren akrilata (ASA). Ispitivanja su provedena na različitim temperaturama za svaki materijal. Testne epruvete izrađeni su pomoću 3D pisaača Raised3D Pro2 Plus koji koristi tehnologiju modeliranja topljenjem filameta, a mehanička ispitivanja rađena su na kidalici marke Zwick/Roell Z400.

Dobivena mehanička svojstva pokazuju da na mehanička svojstva uvelike utječe temperatura staklišta pri kojoj materijali gube neka svoja mehanička svojstva kao što su čvrstoća i tvrdoća. Pošto ispitivanje nije rađeno po standardiziranom postupku za polimerne materijale, nije moguće uspoređivati rezultate s drugim radovima.

The aims of the present thesis are experimental testing of mechanical properties of given polymer materials under uniaxial tensile stress and short-term creep conditions. The tested polymer materials are Polylactic acid (PLA), Acrylonitrile butadiene styrene (ABS) and Acrylonitrile styrene acrylate (ASA). Tests have been performed at different temperatures for each material. Test specimens have been made using a Raised3D Pro2 Plus 3D printer using filament melting modeling technology for 3D printing, while mechanical testing has been carried out using the Zwick / Roell Z400 testing machine.

The obtained mechanical properties show that the mechanical properties are greatly influenced by the glass transition temperature at which the materials lose some of their mechanical properties such as strength and hardness. Since the tests have not been performed according

Kako bi se mogla provesti numerička analiza potrebno je izračunati module elastičnosti pri zadanim temperaturama. Modul elastičnosti računamo pomoću linearne regresije na temelju dobivenih rezultata jednoosnog vlačnog testa. Također je potrebno izračunati koeficijente koji definiraju krivulju puzanja dobivenu eksperimentom. Koeficijenti koji definiraju krivulju puzanja su  $D$ ,  $r$  i  $p$  u jednadžbi:

$$\epsilon(t) = D^{(-T)} \sigma^p t^r.$$

Ti koeficijenti se upisuju u Femap u obliku  $a$ ,  $b$  i  $d$  u jednadžbi:

$$\epsilon(t) = a \cdot (s^{**b})(t^{**d}).$$

Usporedivši te dvije jednadžbe možemo primijetiti da je  $D-T = a$ ,  $s = p$  i  $t = r$ .  $D$ ,  $r$  i  $p$  moraju se dobiti nekom optimizacijskom metodom. U radu je korištena i opisana primjena GRG metode koja se koristi u programu Microsoft Excel. Postupak pripreme numeričke analize, kao i rezultati analize, prikazani su u poglavlju 5. Dobiveni rezultati analize donekle se poklapaju sa eksperimentalnim ispitivanjem što nam omogućuje predviđanje puzanja za ispitani materijal pri mnogo dužem vremenu. Međutim, predvidjeti ponašanje materijala u uvjetima puzanja zahtijeva prethodno eksperimentalno ispitivanje za svako opterećenje i pri svakoj temperaturi zasebno, što oduzima dosta vremena.

to the standardized procedure for polymer materials, it is not possible to compare the results with other scientific papers.

In order to be able to perform a numerical analysis it is necessary to calculate the modulus of elasticity at given temperatures. The module of elasticity is calculated using linear regression method based on the obtained results of a uniaxial tensile test. It is also necessary to calculate the coefficients that define the creep curve obtained by the experiment. The coefficients that define the creep curve are  $D$ ,  $r$  and  $p$  in the equation:

$$\epsilon(t) = D^{(-T)} \sigma^p t^r.$$

These coefficients are entered in the Femap in the form  $a$ ,  $b$  and  $d$  in the equation:

$$\epsilon(t) = a \cdot (s^{**b})(t^{**d}).$$

Comparing these two equations we can notice that  $D-T = a$ ,  $s = p$  i  $t = r$ . In order to obtain these coefficients, the optimization method must be used. The paper uses and describes the application of the GRG method implemented in Microsoft Excel. The procedure for preparing the numerical analysis, as well as the results of the analysis, are presented in Chapter 5. The obtained analysis results show good congruity with experimental testing, which allows us to predict the creep for a much longer period. However, predicting the behavior of the material under creep conditions requires prior experimental testing for each load and at each temperature separately, which is very time consuming.



Prikaz unutrašnjeg djela toplinske komore.  
/ Representation of the inner part of the thermal chamber



ABS testne epruvete nakon eksperimenta puzanja konstantne temperature  $T = 50^\circ\text{C}$ .  
/ ABS test-tubes after the creep experiment at constant temperature  $T = 50^\circ\text{C}$ .

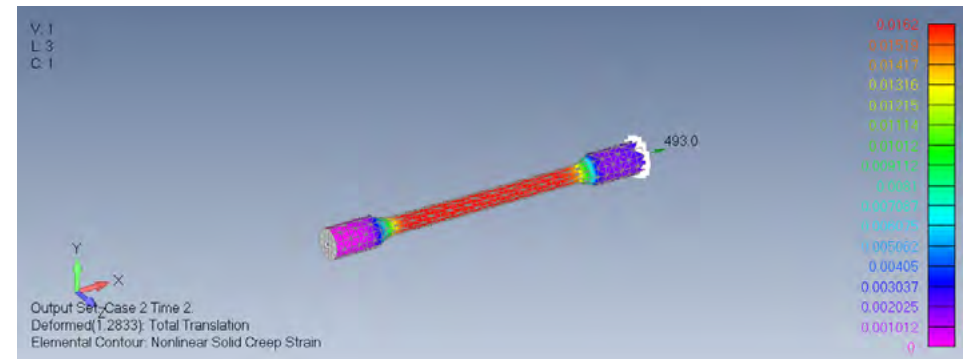

Rezultat numeričke analize puzanja materijala ASA+;  $T = 50^\circ\text{C}$ .  
/ Results of numerical creep analysis of ASA+ material;  $T = 50^\circ\text{C}$ .

IME I PREZIME | NAME AND SURNAME:

Karlo Vulinović

STUDIJSKI PROGRAM | STUDY PROGRAM:

Diplomski sveučilišni studij strojarstva

/ Graduate University Study of Mechanical Engineering

NAZIV RADA | TITLE:

**Analička i numerička analiza čvrstoće konstrukcije električnog bicikla**

Analytical and Numerical Stress Analysis of Electric Bicycle Frame

MENTOR | SUPERVISOR:

Izv. prof. dr. sc. / Assoc. Prof. D. Sc. Marino Brčić

Sažetak:

Summary:

S razvitkom svijeta i društva razvila se potreba za što bržim, lakšim i jednostavnijim prijevoznim sredstvom u svakodnevnom životu. Kao odgovor na te zahtjeve prvo je nastao bicikl, a potom i električni bicikl. S vremenom su se mijenjale primjene i načini vožnje bicikla te su sukladno tome nastajale i različite konstrukcije koje bi omogućile nabolje performanse za tu primjenu. Tako su se razvile brojne vrste bicikala, s obzirom na pri-

With the development of the world and society, the need for a faster, easier and simpler vehicle in everyday life has appeared. In response to these requests, firstly, a bicycle was developed, after which the electric bicycle followed. Over time, the applications and styles of cycling have changed, and accordingly different structures have been designed providing the best performance for this application. Thus, many types of bicycles have

mjenu. Kasnije, razvitkom elektromotora, električni su bicikli našli primjenu u većini područja u kojima su raniju primjenu imali klasični bicikli. U ovome su radu analizirane konstrukcije kostura triju vrsta električnog bicikla:

- » brdski električni bicikl bez stražnjeg amortizera (eng. Hardtail),
- » električni Trekking bicikl
- » brdski električni bicikl sa stražnjim amortizrom (Full suspension).

Konstrukcije su analizirane i dimenzionirane prema teoriji najveće distorzijske energije odnosno prema kriteriju von Misesa. Analize su provedene metodom konačnih elemenata u računalnom programu FEMAP s numeričkim rješavačem NX Nastran na prostornim linijskim konstrukcijama u vidu preliminarnih analiza te na prostornim plošnim konstrukcijama sa ciljem dimenzioniranja optimalnih konstrukcija. Plošne su konstrukcije kostura svih triju analiziranih kategorija električnog bicikla omrežene pločastim konačnim elementima sa svojstvima triju izotropnih materijala i laminatnim konačnim elementima jednoga ortotropnoga materijala te su grafički prikazani i suprotstavljeni rezultati svih triju vrsta konstrukcija iz svakog pojedinog materijala.

Osim samih analiza konstrukcija, u ovom je radu objašnjena i teorijska pozadina provedenih proračuna te su prikazane standardne testne metode prema kojima su analize konstrukcija kostura električnog bicikla izrađene i provedene.

evolved according to their application. Later, with the development of electric motors, electric bicycles have found application in most areas in which classic bicycles had been used. The present thesis analyses the frame structures of three types of electric bicycles:

- » Hardtail electric bicycle,
- » Trekking electric bicycle and
- » Full suspension electric bicycle.

The structures have been analyzed and dimensioned according to the maximum distortion criterion, or von Mises' yield criterion. The finite element analyzes have been performed in the FEMAP computer program with NX Nastran numerical solver on spatial line structures in the form of preliminary analyzes and on spatial surface structures with the aim of sizing optimal structures. The frame constructions of all three analyzed types of the electric bicycle are meshed with plate finite elements with properties of three isotropic materials and laminate finite elements of one orthotropic material. The results of analyzes of all three types of structures from each individual material are graphically presented and compared.

In addition to the structural analyzes, this master's thesis also explains the theoretical background of the numerical calculations performed and it presents standard test methods according to which the analyzes of the structures of electric bicycle frames were created and carried out.



*Prostorna konstrukcija kostura brdskog bicikla sa stražnjim amortizerom.  
/ Spatial construction of a Full suspension electric bicycle.*

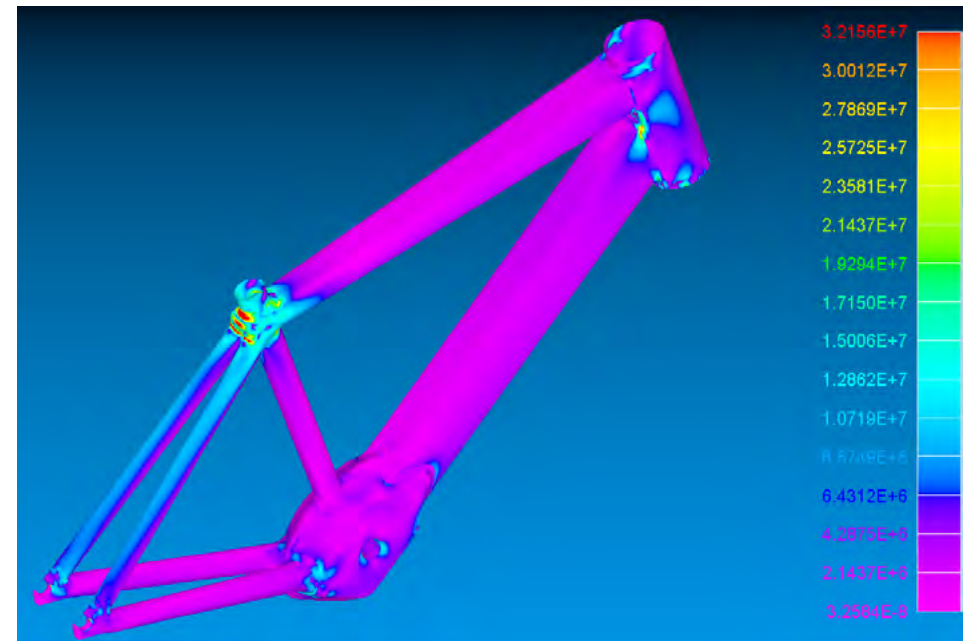

*Rezultati numeričke analize napreznja u modelu čelične konstrukcije kostura brdskog električnog bicikla bez stražnjeg amortizera.*

*/ Results of numerical stress analysis in a model of steel structure of a Hardtail electric bicycle*

IME I PREZIME | NAME AND SURNAME:

Branimir Tramošljika

STUDIJSKI PROGRAM | STUDY PROGRAM:

Diplomski sveučilišni studij strojarstva

/ Graduate University Study of Mechanical Engineering

NAZIV RADA | TITLE:

**Analiza termoelektrane Plomin C: Usporedba varijanti na plin i na ugljen**

Analysis of the Thermal Power Plant Plomin C: Comparison of the Gas and Coal Variants

MENTORI | SUPERVISORS:

Doc. dr. sc. / Assist. Prof. D. Sc. Paolo Blecich

Doc. dr. sc. / Assist. Prof. D. Sc. Igor Bonefačić

Sažetak:

U ovome je diplomskom radu prikazana termodinamička analiza dvije vrste procesa. Prikazana je analiza termoelektrane na ugljen kao pogonsko gorivo, a potom je prikazana termodinamička analiza kombinirane plinske elektrane. Obje elektrane su iste nazivne snage od 500 MW. Kombinirana plinska elektrana analizirana je samo za slučaj čistog kondenzacijskog načina rada. Prije spomenute analize dan je pregled postojeće elektroenergetske slika Hrvatske.

Naime, Republika Hrvatska uvozi veliki dio električne energije za vlastite potrebe i stoga se analizira trend potrošnje električne energije u Hrvat-

Summary:

The present thesis shows the thermodynamic analysis of two types of processes. On the one hand, the analysis of the coal-fired thermal power plant is given, while on the other the thermodynamic analysis of the combined gas power plant is presented. Both power plants have the same nominal power of 500 MW. The combined gas power plant is only displayed in the case of a pure condensation mode. Before the mentioned analysis, the existing electricity situation of the Republic of Croatia is given.

Namely, the Republic of Croatia imports a large part of electricity for its own needs and the trend

skoj kao i postojeći energetska kapaciteti. Potom se analiziraju osnovni procesi koji se odvijaju u oba tipa elektrane te će se analizirati gorivo za oba tipa. Naime, trenutno se u TE Plomin koristi uvozni ugljen koji se doprema pomorskim putem. Navedeni ugljen bi koristila i buduća termoelektrana ukoliko se izvede na takvo pogonsko gorivo. U slučaju kombinirane termoelektrane na prirodni plin, potrebno je napraviti transportni vod do okolice elektrane te još mnoge druge zahvate koji će se analizirati. Provedena je termodinamička analiza oba tipa elektrane, određeni su protoci pare, potrebna količina goriva i sl. Uz spomenuto, pojedinačno su prikazane emisije onečišćivača i njihova usporedba s trenutnim stanjem. Naime, planirani zahvat uključuje zamjenu TE Plomin 1, koji trenutno nije u pogonu, s novim kapacitetom od 500 MW. Iako je TE Plomin 1 manjeg kapaciteta od TE Plomin 2, činio je glavnu emisiju štetnih plinova u atmosferi u razdoblju od 2000. do 2010. godine.

Na kraju rada prikazana je osnovna ekonomska usporedba u slučaju gradnje termoelektrane na ugljen kao pogonsko gorivo ili gradnju kombinirane termoelektrane na prirodni plin. Uspoređeni rezultati uključuju i cijenu emisijske jedinice koja se plaća po emitiranoj količini ugljikovog dioksida.

of electricity consumption in Croatia is studied along with the existing energy capacities. After that, the basic processes that take place in both types of power plants are analyzed along with the fuel types. Specifically, the TPP Plomin uses imported coal delivered by sea. This coal would also be used for the future thermal power plant. In the case of a natural gas power plant, it is necessary to make a conduit to the vicinity of the power plant and many other interventions which are analyzed in the thesis.

Thermodynamic analysis of both types of power plants is carried out, flows of steam, the required amount of fuel, etc. In addition, pollutant emissions and their comparison with the current situation are presented individually. Specifically, the planned intervention involves the replacement of the Plomin 1 TPP, which is currently not in operation, with a new capacity of 500 MWs. Although the Plomin 1 TPP is of less capacity than the Plomin 2 TPP, it accounted for the majority of toxic emissions into the atmosphere, in the period between 2000 and 2010.

At the end of the thesis, a basic economic comparison is presented in the case of the construction of a coal-fired power plant as a fuel or the construction of a combined gas-fired power plant. The compared results also include the cost of the emission unit paid for by the amount of carbon dioxide emitted.

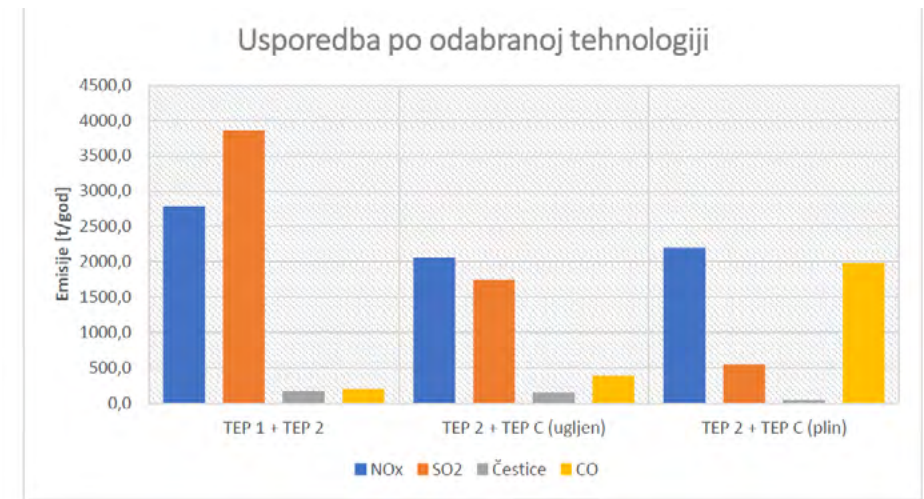

Usporedba emisija NOx, SOx, CO i čestica iz termoelektrana Plomin 1 (TEP 1), Plomin 2 (TEP 2) i planiranog trećeg bloka (TEP C)  
/ Comparison of NOx, SOx, CO and particles from Plomin 1 (TEP 1), Plomin 2 (TEP 2) and the planned third block (TEP C)

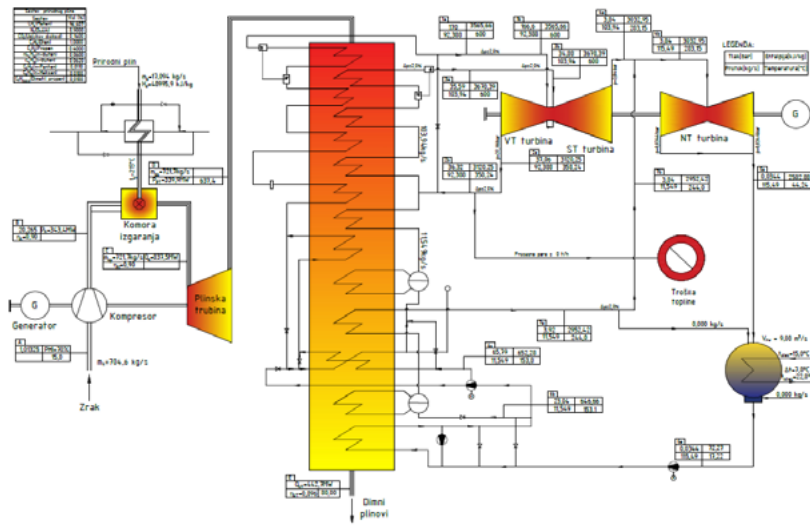

Shema kombiniranog (plinsko-parnog) procesa u termoelektrani TE Plomin C  
/ Scheme of combined (gas-steam) process in thermal power plant TPP Plomin C



# 3 studijski programi na fakultetu

## study programs at the faculty

PREDDIPLOMSKI SVEUČILIŠNI STUDIJ 3-godišnji (180 ECTS)		UNDERGRADUATE UNIVERSITY STUDY 3 years (180 ECTS)	
Studij	Naziv	Study	Title
Strojarstvo	Sveučilišni prvostupnik inženjer strojarstva	Mechanical Engineering	University Bachelor Engineer of Mechanical Engineering
Brodogradnja	Sveučilišni prvostupnik inženjer brodogradnje	Naval Architecture	University Bachelor Engineer of Naval Architecture
Elektrotehnika	Sveučilišni prvostupnik inženjer elektrotehnike	Electrical Engineering	University Bachelor Engineer of Electrical Engineering
Računarstvo	Sveučilišni prvostupnik inženjer računarstva	Computing	University Bachelor Engineer of Computing

DIPLOMSKI SVEUČILIŠNI STUDIJ 2-godišnji (120 ECTS)		GRADUATE UNIVERSITY STUDY 2 years (120 ECTS)	
Studij	Naziv	Study	Title
Strojarstvo	Magistar inženjer strojarstva	Mechanical Engineering	Master of Mechanical Engineering
Brodogradnja	Magistar inženjer brodogradnje	Naval Architecture	Master of Naval Architecture
Elektrotehnika	Magistar inženjer elektrotehnike	Electrical Engineering	Master of Electrical Engineering
Računarstvo	Magistar inženjer računarstva	Computing	Master of Computing

POSILIJDIPLOMSKI SVEUČILIŠNI (DOKTORSKI) STUDIJ 3-godišnji (180 ECTS)		POSTGRADUATE UNIVERSITY (DOCTORAL) STUDY 3 years (180 ECTS)	
Studij	Naziv	Study	Title
Strojarstvo	Doktor znanosti, područje Tehničkih znanosti	Mechanical Engineering	D. Sc. in the area of Engineering Sciences
Temeljne tehničke znanosti		Basic Engineering Sciences	
Brodogradnja		Naval Architecture	
Interdisciplinarne tehničke znanosti		Interdisciplinary Engineering Sciences	
Elektrotehnika		Electrical Engineering	
Računarstvo		Computer Science	

PREDDIPLOMSKI STRUČNI STUDIJ 3-godišnji (180 ECTS)		UNDERGRADUATE VOCATIONAL STUDY 3 years (180 ECTS)	
Studij	Naziv	Study	Title
Strojarstvo	Stručni prvostupnik inženjer strojarstva	Mechanical Engineering	Bachelor Engineer of Mechanical Engineering
Brodogradnja	Stručni prvostupnik inženjer brodogradnje	Naval Architecture	Bachelor Engineer of Naval Architecture
Elektrotehnika	Stručni prvostupnik inženjer elektrotehnike	Electrical Engineering	Bachelor Engineer of Electrical Engineering

Studiji na Tehničkom fakultetu ustrojeni su prema Bolonjskom modelu 3 + 2 + 3, što znači da se obrazovanje provodi kroz preddiplomski sveučilišni studij u trajanju od tri godine kojim se stječe 180 ECTS bodova, zatim diplomski sveučilišni studij u trajanju od dvije godine kojim se stječe 120 ECTS bodova te poslijediplomski sveučilišni (doktorski) studij u trajanju od tri godine kojim se stječe 180 ECTS bodova.

Osim tih studija, obrazovanje se provodi i kroz preddiplomske stručne studije u trajanju od tri godine kojima se stječe također 180 ECTS bodova. Taj je sustav s vrstama pojedinih studija i stečenim nazivima prikazan u tablici. U nastavku su opisane osnovne značajke pojedinog studija.

### PREDDIPLOMSKI SVEUČILIŠNI STUDIJ STROJARSTVA

Preddiplomski sveučilišni studij strojarstva pripremat će studente za diplomski sveučilišni studij strojarstva, ali će im pružati i mogućnost zapošljavanja na odgovarajućim stručnim poslovima. Studij ima za cilj osposobljavanje studenata za primjenu temeljnih i specijalističkih znanja iz strojarstva, prepoznavanje, oblikovanje i rješavanje problema iz prakse, primjenu drugih stečenih znanja iz tehnike, matematike i računarstva, korištenje suvremenih inženjerskih alata, razumijevanje timskog rada i učinkovite komunikacije, razumijevanje etičnosti i etičke odgovornosti, te razumijevanje utjecaja inženjerskih rješenja na društvo i okolinu. Završeni student ovog studija mora biti sposoban uključiti se u kontinuirano obrazovanje i profesionalni razvoj, te posjedovati šire obrazovanje (poznavanje tema izvan tehnike).

Odluči li se student za nastavak studija, on će moći upisati diplomski sveučilišni studij strojarstva na Tehničkom fakultetu Sveučilišta u Rijeci, odnosno isti takav studij na ostalim sveučilištima u Republici Hrvatskoj.

Studies at the Faculty of Engineering are set according to the Bologna model 3 + 2 + 3, which means that education continues through a three year long undergraduate university study resulting in 180 ECTS credits obtained, followed by a two year graduate university study resulting in 120 ECTS credits obtained and a postgraduate university (doctoral) study which lasts three years and results in 180 ECTS credits obtained.

Apart from these studies, education is accomplished through a three year undergraduate vocational study that results in 180 ECTS credits. The curricula with the respective types of studies and obtained titles are shown in the following table. The basic characteristics of each study are described below.

### UNDERGRADUATE UNIVERSITY STUDY OF MECHANICAL ENGINEERING

Undergraduate university study in Mechanical Engineering shall prepare students for the graduate university study in Mechanical Engineering, and shall also provide opportunities for employment at appropriate professional positions. The aim of the study is to train students to apply basic and specialist knowledge in mechanical engineering, to recognise, form, and solve practical problems, to apply other acquired knowledge in engineering, mathematics, and computer engineering, to use modern engineering tools, to understand teamwork and effective communication, to understand ethics and ethical responsibility, and to understand the influence of engineering solutions on the society and the surroundings. Graduating students must be capable of pursuing lifelong learning and professional development, and they must have a broad education (being familiar with topics outside engineering). If students decide to continue their study, they shall be able to enrol into the graduate university study in Mechanical Engineering at the University of Rijeka, Faculty of Engineering, or same study at other universities in Croatia.



Prediplomski sveučilišni studij													
S	Strojstvo			Brodogradnja			Elektrotehnika			Računarstvo			
	Predmet	N	B	Predmet	N	B	Predmet	N	B	Predmet	N	B	
I	Matematika I	6	7	Matematika I	6	7	Matematika I	6	7	Matematika I	6	7	
	Statika	5	6	Statika	5	6	Fizika I	4	5	Uvod u modernu fiziku	3	4	
	Materijali I	4	4	Materijali I	4	4	Osnove elektrotehnike I	6	7	Elektrotehnika R	4	7	
	Elektrotehnika	3	5	Elektrotehnika	3	5	Programska podrška u inženjerstvu	4	6	Programiranje I	4	6	
	Primjena računala u inženjerstvu	3	4	Primjena računala u inženjerstvu	3	4	Inženjerska grafika i dokumentiranje	4	5	Računalne vještine	2	3	
	Inženjerska grafika	4	4	Inženjerska grafika	4	4		4	4	Engleski jezik I	3	3	
	Matematika II	6	7	Matematika II	6	7	Matematika II	6	7	Matematika II	6	7	
	Kinematika	5	6	Kinematika	5	6	Fizika II	4	5	Elektrotehnika	4	7	
	Materijali II	6	7	Čvrstoća konstrukcija	6	7	Osnove elektrotehnike II	6	7	Programiranje II	5	7	
	Oblikovanje pomoću računala	4	5	Oblikovanje pomoću računala	4	5	Programiranje	4	6	Digitalna logika	4	6	
III	Dinamika	4	5	Dinamika	4	5	Tehnologija materijala	3	5	Engleski jezik II	3	3	
	Mehanika fluida	5	5	Mehanika fluida	5	5	Inženjerska matematika ET	5	7	Inženjerska matematika R	4	5	
	Termodinamika I	6	7	Zahtjevi	3	4	Mjerenja u elektrotehnici	5	7	Algoritmi i strukture podataka	5	7	
	Mjerenja i kontrola kvalitete	3	5	Termodinamika BG	4	4	Elektrotehnika	4	6	Grada računala	4	6	
	računarske metode	4	5	Uvod u plovidne objekte	3	4	Električne mreže	4	7	Signali i sustavi	4	6	
	Strani jezik I	2	3	Osnove konstrukcijskih elemenata	4	4	Strani jezik I	2	3	Uvod u objektno orj. programiranje	4	6	
				Engleski jezik I	2	3							
				Inženjerska statistika	4	5	Digitalna elektronika	4	6	Operacijski sustavi	4	7	
				Konstrukcijski elementi I	5	7	Elektronika II	4	6	Računalne mreže	4	7	
				Proizvodne tehnologije	4	5	Osnove regulacijske tehnike	4	6	Računalna grafika	4	7	
V	Konstrukcijski elementi II	6	7	Konstrukcija broda I	4	6	Izborni kolegij I	4	4	Izborni kolegij I	3	4	
	Stručna praksa I	5	5	Stručna praksa I	5	5	Strani jezik II	2	3	Stručna praksa I	5	5	
	Toplinski strojevi i uređaji	4	5	Plovidnost i stabilitet broda	6	7	Električni strojevi	5	6	Ugradbeni računalski sustavi	5	7	
	Proizvodni strojevi, alati i naprave	4	5	Oprema broda	4	6	Energetska elektronika	5	6	Baze podataka	4	6	
	Kolegij izborne skupine	4	4	Konstrukcija broda II	4	6	Signali i sustavi	4	6	Razvoj web aplikacija	4	7	
	Tehnološki procesi	4	4	Tehnologija brodogradnje	4	6	Kolegij izborne skupine	4	7	Izborni kolegij II	4	5	
	Izborni projekt	3	5	Izborni projekt	3	5	Izborni projekt	3	5	Izborni projekt	3	5	
	Energetski sustavi	4	4	Organizacija i ekonomika posl. sust.	3	4	Elektromotorni pogoni	4	5	Programsko inženjerstvo	5	7	
	Automatizacija	3	4	Hydrodinamika plovnih objekata I	6	8	Organizacija i ekonomika posl. sust.	3	4	Organizacija i ekonomika posl. sust.	3	4	
	Kolegij izborne skupine	4	4	Slobodni kolegij I	3	4	Kolegij izborne skupine	5	7	Uvod u umjetnu inteligenciju	4	5	
VI	Organizacija i ekonomika posl. sust.	3	4	Slobodni kolegij II	3	4	Slobodni kolegij	3	4	Slobodni kolegij	3	4	
	Slobodni kolegij	3	4	Završni rad	10	10	Završni rad	10	10	Završni rad	10	10	
	Završni rad	10	10										

(Studijski programi pojedinih studija prikazani su na gornjoj i na tablicama koje slijede: sa S je označen semestar u kojem se predmet predaje, s N su označeni sati nastave tjedno, a s B broj ECTS bodova pripadnog predmeta.)



Undergraduate University Studies												
S	Mechanical Engineering			Naval Architecture			Electrical Engineering			Computing		
	Course	N	B	Course	N	B	Course	N	B	Course	N	B
I	Mathematics I	6	7	Mathematics I	6	7	Mathematics I	6	7	Mathematics I	6	7
	Statics	5	6	Statics	5	6	Physics I	4	5	Introduction to Modern Physics	3	4
	Materials I	4	4	Materials I	4	4	Fundamentals of Electrical Engineering I	6	7	Electrical Engineering CE	4	7
	Electrical Engineering	3	5	Electrical Engineering	3	5	Computer Software in Engineering	4	6	Programming I	4	6
	Computer Applications in Engineering	3	4	Computer Applications in Engineering	3	4	Engineering Graphics and Documenting	4	5	Computer Skills	2	3
	Engineering Graphics	4	4	Engineering Graphics	4	4		4	4	English Language I	3	3
	Mathematics II	6	7	Mathematics II	6	7	Mathematics II	6	7	Mathematics II	6	7
	Kinematics	5	6	Kinematics	5	6	Physics II	4	5	Electronics	4	7
	Strength of Materials I	6	7	Strength of Materials	6	7	Fundamentals of Electrical Engineering II	6	7	Programming II	5	7
	Materials II	3	5	Materials II	3	5	Programming	4	6	Digital Logic	4	6
III	Modelling by Computer	4	5	Modelling by Computer	4	5	Materials Technology	3	5	Mathematics for Engineers II	3	3
	Dynamics	4	5	Dynamics	4	5	Measurements in the Electrical Engineering	5	7	Algorithms and Data Structures	4	5
	Fluid Mechanics	5	5	Fluid Mechanics	5	5	Electronics I	4	6	Computer Architecture	4	6
	Thermodynamics	6	7	Thermodynamics NA	4	5	Electrical Circuits	4	7	Signals and Systems	4	6
	Measurements and Quality Control	3	5	Introduction to Marine Vessels	3	4	Foreign Language I	2	3	Introduction to Object Oriented Programming	4	6
	Computational Methods	4	4	Basis of Machine Elements Design	4	4		4	4			
	Foreign Language I	2	3	English Language I	2	3		4	4			
	Engineering Statistics	4	5	Engineering Statistics	4	5	Digital Electronics	4	6	Operating Systems	4	7
	Machine Elements Design I	5	7	Ship Hull Forms	5	6	Electronics II	4	6	Computer Networks	4	7
	Hydraulic Machines	4	5	Basics of Ship Production	3	5	Fundamentals of Automatic Control	4	6	Computer Graphics	4	7
V	Production Technologies	4	5	Ship Structure I	4	6	Elective Subject	4	4	Elective Subject I	3	4
	Foreign Language II	2	3	English Language II	2	3	Foreign Language II	2	3	Professional practice I	5	5
	Professional practice I	3	5	Professional Practice I	3	5	Professional practice I	3	5			
	Machine Elements Design II	6	7	Seaworthiness and Stability of the Ship	6	7	Electrical Machines	5	6	Embedded Systems	5	7
	Heat Engines and Devices	4	5	Ship Equipment	4	6	Power Electronics	5	6	Database Systems	4	6
	Production Machines, Tools, Jigs and Fixtures	4	5	Ship Structure II	4	6	Signals and Systems	4	7	Web Application Development	4	7
	Elective group course	4	4	Shiplubbing Technology	4	6	Elective group course	4	7	Elective Subject II	4	5
	Technological Processes	4	4	Elective project	3	5	Elective project	3	5	Elective project	3	5
	Elective project	3	5									
	Machine Elements	4	4	Organization and Economics of Business System	3	4	Organization and Economics of Business System	3	4	Software Engineering	5	7
VI	Automation	3	4	Marine Hydrodynamics I	6	8	Organization and Economics of Business System	3	4	Organization and Economics of Business System	3	4
	Elective group course	4	4	Free Elective Subject I	3	4	Free Elective Subject I	3	4	Introduction to Artificial Intelligence	4	5
	Organization and Economics of Business System	3	4	Free Elective Subject II	3	4	Free Elective Subject II	3	4	Free Elective Subject	3	4
	Free Elective Subject	3	4	Final Work	10	10	Final Work	10	10	Final Work	10	10
	Final work	10	10									

(Curricula of the described studies are presented above and in the tables below: S signifies the semester in which the course is placed, with N lecturing hours per week, and B the number representing ECTS credits.)

**PREDDIPLOMSKI SVEUČILIŠNI STUDIJ  
BRODOGRADNJE**

Preddiplomski sveučilišni studij brodogradnje pripremat će studente za diplomski sveučilišni studij brodogradnje, ali će im pružati i mogućnost zapošljavanja na odgovarajućim stručnim poslovima. Na preddiplomskom studiju brodogradnje polaznicima će se u razumnoj količini i na dovoljno visokoj razini davati znanje iz temeljnih tehničkih sadržaja s jedne strane, te iz glavnih brodograđevnih sadržaja s druge strane, kako bi u svojoj radnoj praksi, kao i u svom daljnjem stručnom i znanstvenom usavršavanju, uvijek bili na razini postavljenih zadataka. Svojim opsegom i sadržajem ovaj će studij polazniku davati potrebnu širinu stručnih znanja koja ga po završetku studija osposobljava za samostalan rad, odnosno za rad u stručnim timovima u bilo kojem segmentu brodograđevne struke. Završeni student ovog studija mora biti sposoban uključiti se u kontinuirano obrazovanje i profesionalni razvoj, te posjedovati šire obrazovanje (poznavanje tema izvan tehnike).

Odluči li se student za nastavak studija, on će moći upisati diplomski sveučilišni studij brodogradnje na Tehničkom fakultetu Sveučilišta u Rijeci, odnosno isti takav studij na ostalim sveučilištima u Republici Hrvatskoj.

**PREDDIPLOMSKI SVEUČILIŠNI STUDIJ  
ELEKTROTEHNIKE**

Preddiplomski sveučilišni studij elektrotehnike pripremat će studente za diplomski sveučilišni studij elektrotehnike, ali će im pružati i mogućnost zapošljavanja na odgovarajućim stručnim poslovima. Studij ima za cilj osposobljavanje studenata za primjenu temeljnih i specijalističkih znanja iz elektrotehnike, prepoznavanje, oblikovanje i rješavanje problema iz prakse, primjenu drugih stečenih znanja iz tehnike, matematike i računarstva, korištenje suvremenih inženjerskih alata, razumijevanje timskog rada i učinkovite komunikacije, razumijevanje etičnosti i etičke odgovornosti, te razumijevanje utjecaja inženjerskih rješenja na društvo i okolinu. Završeni student ovog studija mora biti sposoban uključiti se u kontinuirano obrazovanje i profesionalni razvoj, te posjedovati šire obrazovanje (poznavanje tema izvan tehnike).

Odluči li se student za nastavak studija, on će moći upisati diplomski sveučilišni studij elektrotehnike na Tehničkom fakultetu Sveučilišta u Rijeci, odnosno isti takav studij na ostalim sveučilištima u Republici Hrvatskoj.

**UNDERGRADUATE UNIVERSITY STUDY OF  
NAVAL ARCHITECTURE**

Undergraduate university study in Naval Architecture shall prepare students for the graduate university study in Naval Architecture, and shall also provide opportunities for employment at appropriate professional positions. In the undergraduate study in Naval Architecture, the students shall be provided in a reasonable amount and at a sufficiently high level with knowledge in basic engineering on the one hand, and on the other, in main subjects of naval architecture, so that in their student practice, as well as in their further professional development, they shall meet the demands of the given tasks. In its scope and content, the study shall provide students with the necessary breadth of professional knowledge that shall enable them at the end of their study to carry out work independently and in professional teams in any segment of naval architecture. Graduating students must be capable of pursuing lifelong learning and professional development, and they must have a broad education (being familiar with topics outside engineering). If students decide to continue their study, they shall be able to enrol into the graduate university study in Naval Architecture at the University of Rijeka, Faculty of Engineering, or same study at other universities in Croatia.

**UNDERGRADUATE UNIVERSITY STUDY OF  
ELECTRICAL ENGINEERING**

Undergraduate university study in Electrical Engineering shall prepare students for the graduate university study in Electrical Engineering, and shall also provide opportunities for employment at appropriate professional positions. The aim of the study is to train students to apply basic and specialist knowledge in electrical engineering, to recognise, form, and solve practical problems, to apply other acquired knowledge in engineering, mathematics, and computer engineering, to use modern engineering tools, to understand teamwork and effective communication, to understand ethics and ethical responsibility, and to understand the influence of engineering solutions on the society and the surroundings. Graduating students must be capable of pursuing lifelong learning and professional development, and they must have a broad education (being familiar with topics outside engineering). If students decide to continue their study, they shall be able to enrol into the graduate university study in Electrical Engineering at the University of Rijeka, Faculty of Engineering, or same study at other universities in Croatia.

**PREDDIPLOMSKI SVEUČILIŠNI STUDIJ  
RAČUNARSTVA**

Preddiplomski sveučilišni studij računarstva pripremat će studente za diplomski sveučilišni studij računarstva, ali će im pružati i mogućnost zapošljavanja na odgovarajućim stručnim poslovima. Studij ima za cilj osposobljavanje studenata za primjenu temeljnih i specijalističkih znanja iz računarstva za karakterizaciju, projektiranje, izvedbu, eksploatiranje i održavanje informacijskih i računalnih sustava i procesa, oblikovanje i rješavanje problema iz prakse, primjenu informacijske i komunikacijske tehnologije u privrednim i društvenim subjektima, korištenje suvremenih inženjerskih alata, razumijevanje timskog rada i učinkovite komunikacije, razumijevanje etičnosti i etičke odgovornosti, vrednovanje informacijsko-komunikacijske tehnologije na osnovi kritičkog razmišljanja i intelektualnog poštenja te razumijevanje utjecaja inženjerskih rješenja na društvo i okolinu. Završeni student ovog studija mora biti sposoban uključiti se u kontinuirano obrazovanje i profesionalni razvoj, te posjedovati šire obrazovanje (poznavanje tema izvan tehnike).

Odluči li se student za nastavak studija, on će moći upisati diplomski sveučilišni studij računarstva na Tehničkom fakultetu Sveučilišta u Rijeci, odnosno isti takav studij na ostalim sveučilištima u Republici Hrvatskoj.

**DIPLOMSKI SVEUČILIŠNI STUDIJ  
STROJARSTVA**

Diplomskim sveučilišnim studijem strojarstva studenti stječu potrebna usko-specijalistička znanja iz navedenih područja te su time osposobljeni za obavljanje najsloženijih inženjerskih zadaća temeljenih na znanstvenom pristupu rješavanju problema. Stječu se nova specijalistička znanja iz strojarstva i sposobnost njegove primjene, kao i poznavanje i primjenu drugih specijalističkih znanja iz tehnike, matematike i računarstva. Studenti usvajaju sposobnost kontinuiranog obrazovanja i samoobrazovanja, sposobnosti samostalnog istraživanja, otkrivanja novih znanja, pripreme i izvođenja eksperimenata, te tumačenja podataka. Studijem se stječu znanja i kompetencije potrebne za projektiranje novih sustava, komponenata ili procesa, te učinkovito djelovanje u ulozi vođe tima. Studijski program sličan je programima studija na inozemnim visokim učilištima uz postizanje specifičnih zahtjeva sredine za koju se prvenstveno školuju kadrovi na Tehničkom fakultetu Sveučilišta u Rijeci. U studijski program ukomponirane su preporuke iz Bolonjske deklaracije koje se odnose na način osiguranja kvalitete studijskog

**UNDERGRADUATE UNIVERSITY STUDY OF  
COMPUTING**

Undergraduate university study in Computing shall prepare students for the graduate university study in Computing, and shall also provide opportunities for employment at appropriate professional positions. The aim of the study is to train students to apply basic and specialist knowledge in computer engineering to characterise, design, execute, exploit, and maintain information and computer systems and processes, to form and solve practical problems, to apply information and communication technology in economic and social entities, to use modern engineering tools to understand teamwork and effective communication, to understand ethics and ethical responsibility, to evaluate information and communication technology on the basis of critical thinking and intellectual integrity, and to understand the influence of engineering solutions on the society and the surroundings. Graduating students must be capable of pursuing lifelong learning and professional development, and they must have a broad education (being familiar with topics outside engineering). If students decide to continue their study, they shall be able to enrol into the graduate university study in Computing at the University of Rijeka, Faculty of Engineering, or same study at other universities in Croatia.

**GRADUATE UNIVERSITY STUDY OF  
MECHANICAL ENGINEERING**

Graduate university study in Mechanical Engineering enables students to acquire highly specialist knowledge in the field and to be trained to perform the most complex engineering tasks based on the scientific approach to problem-solving. New specialist knowledge is acquired in mechanical engineering, and students are able to apply that knowledge; the same is true for other specialist knowledge in engineering, mathematics, and computer engineering. Students gain the ability to engage in continuing education and professional development, the ability to carry out independent research, to discover new knowledge, to prepare and conduct experiments, and to interpret data. The study enables the acquisition of knowledge and competencies needed for designing new systems, components, or processes, and to act effectively in the role of a team leader. The study programme is similar to those at higher education institutions abroad, but meeting the specific demands of the community and region in which the University of Rijeka, Faculty of Engineering operates. The study programme incorporates recommendations from the





programa, mobilnost pri studiranju i priznavanju diploma.

Na ovom studiju omogućena je specijalizacija u jednom od sljedećih područja:

- » Konstruiranje i mehatronika
- » Računarska mehanika i inženjerstvo
- » Tehnološko-informatičko inženjerstvo
- » Industrijsko inženjerstvo i management
- » Termotehnika
- » Procesno i energetsko strojarstvo
- » Brodostrojarstvo
- » Inženjerstvo materijala

#### DIPLOMSKI SVEUČILIŠNI STUDIJ BRODOGRADNJE

Na diplomskom sveučilišnom studiju brodogradnje osposobljavat će se budući stručnjaci koji će raditi na poslovima i zadacima projektiranja i konstruiranja različitih vrsta i tipova plovni objekata, razvoja i vođenja tehnoloških procesa, poglavito gradnje i održavanja plovni objekata i objekata morske tehnologije, zatim na poslovima klasifikacijskih i nadzornih institucija, te drugim poslovima u širem području brodogradnje i inženjerstva morske tehnologije, odnosno pomorstva.

Ovaj studijski program nudi specijalizaciju u sljedećim područjima:

- » Projektiranje i konstrukcija plovni objekata
- » Tehnologija i organizacija brodogradnje

Studijski program slijedi preporuke iz Bolonjske deklaracije koje se odnose na način osiguranja kvalitete studijskog programa, mobilnosti pri studiranju te postupke priznavanja diploma.

#### DIPLOMSKI SVEUČILIŠNI STUDIJ ELEKTROTEHNIKE

Diplomskim sveučilišnim studijem elektrotehnike studenti stječu potrebna usko-specijalistička znanja iz navedenih područja te su time osposobljeni za obavljanje najsloženijih inženjerskih zadataka temeljenih na znanstvenom pristupu rješavanju problema. Stječu se nova specijalistička znanja iz elektrotehnike i sposobnost njegove primjene, kao i poznavanje i primjenu drugih specijalističkih znanja iz tehnike, matematike i računarstva. Studenti usvajaju sposobnost kontinuiranog obrazovanja i samoobrazovanja, sposobnosti samostalnog istraživanja, otkrivanja novih znanja, pripreme i izvođenja eksperimenata, te tumačenja podataka. Studijem se stječu znanja i kompetencije potrebne za projektiranje novih sustava, komponenata ili procesa, te učinkovito djelovanje u ulozi vođe tima. Studijski program sličan je programima studija na inozemnim visokim učilištima uz postizanje specifičnih zahtjeva sredine za koju se prvenstveno školuju kadrovi

Bologna Declaration that refer to programme quality assurance, mobility, and diploma recognition.

This study programme enables specialisation in one of the following areas:

- » Mechanical Engineering Design and Mechatronics
- » Computational Mechanics and Engineering
- » Technology Computational Engineering
- » Industrial Engineering and Management
- » Thermal Engineering
- » Process and Energy Engineering
- » Marine Engineering
- » Materials Engineering

#### GRADUATE UNIVERSITY STUDY OF NAVAL ARCHITECTURE

Graduate university study in Naval Architecture trains future experts who will work on jobs and tasks of designing and building different kinds and types of ships, developing and supervising technological processes, especially concerning construction and maintenance of ships and marine technology objects, jobs related to classification and inspection institutions, and other jobs in the broader field of naval architecture and marine technology engineering, that is, maritime affairs.

This study programme enables specialisation in the following areas:

- » Design and Construction of Ships
- » Technology and Organization of Shipbuilding

The study programme follows recommendations from the Bologna Declaration that refer to programme quality assurance, mobility, and diploma recognition.

#### GRADUATE UNIVERSITY STUDY OF ELECTRICAL ENGINEERING

Graduate university study in Electrical Engineering enables students to acquire highly specialist knowledge in the field and to be trained to perform the most complex engineering tasks based on the scientific approach to problem-solving. New specialist knowledge is acquired in electrical engineering, and students are able to apply that knowledge; the same is true for other specialist knowledge in engineering, mathematics, and computer engineering. Students gain the ability to engage in continuing education and professional development, the ability to carry out independent research, to discover new knowledge, to prepare and conduct experiments, and to interpret data. The study enables the acquisition of knowledge and competencies needed for designing new

na Tehničkom fakultetu Sveučilišta u Rijeci. U studijski program ukomponirane su preporuke iz Bolonjske deklaracije koje se odnose na način osiguranja kvalitete studijskog programa, mobilnost pri studiranju i priznavanju diploma.

Na ovom studiju omogućena je specijalizacija u jednom od sljedećih područja:

- » Automatika
- » Elektroenergetika

#### DIPLOMSKI SVEUČILIŠNI STUDIJ RAČUNARSTVA

Diplomskim sveučilišnim studijem računarstva studenti stječu potrebna usko-specijalistička znanja iz navedenih područja te su time osposobljeni za obavljanje najsloženijih inženjerskih zadataka temeljenih na znanstvenom pristupu rješavanju problema. Studenti usvajaju sposobnost interdisciplinarnog pristupa integraciji sustava, obrade informacija i traženja inovativnih rješenja. Samostalno će projektirati, upravljati, analizirati problem i predlagati rješenja vezana uz razvoj sklopovske i programske podrške i umrežavanja sustava. Znat će učinkovito birati i primjenjivati odgovarajuće suvremene alate i metode iz struke na kompleksne inženjerske aktivnosti. Steći će znanja i vještine za projektiranje sustava, komponenata i procesa koji odgovaraju specifičnim potrebama određenih područja.

Studijski program sličan je programima studija na inozemnim visokim učilištima uz postizanje specifičnih zahtjeva sredine za koju se prvenstveno školuju kadrovi na Tehničkom fakultetu Sveučilišta u Rijeci. U studijski program ukomponirane su preporuke iz Bolonjske deklaracije koje se odnose na način osiguranja kvalitete studijskog programa, mobilnost pri studiranju i priznavanju diploma.

Na ovom studiju omogućena je specijalizacija u jednom od sljedeća dva područja:

- » Programsko inženjerstvo
- » Računalni sustavi

systems, components, or processes, and to act effectively in the role of a team leader. The study programme is similar to those at higher education institutions abroad, but meeting the specific demands of the community and region in which the University of Rijeka Faculty of Engineering operates. The study programme incorporates recommendations from the Bologna Declaration that refer to programme quality assurance, mobility, and diploma recognition.

This study programme enables specialisation in one of the following areas:

- » Automation
- » Power Engineering

#### GRADUATE UNIVERSITY STUDY OF COMPUTING

Graduate university study in Computing enables students to acquire highly specialist knowledge in the field and to be trained to perform the most complex engineering tasks based on the scientific approach to problem-solving. Students develop the ability of an interdisciplinary approach to system integration, information processing, and to the search for innovative solution. Student independently design, manage, and analyse problems and offer solutions related to the development of circuit and software support and system networks. They efficiently choose and apply modern tools and methods from the profession to complex engineering activities. They acquire knowledge and skills needed for designing systems, components, and processes that meet specific demands of a given field. The study programme is similar to those at higher education institutions abroad, but meeting the specific demands of the community and region in which the University of Rijeka, Faculty of Engineering operates. The study programme incorporates recommendations from the Bologna Declaration that refer to programme quality assurance, mobility, and diploma recognition.

This study programme enables specialisation in one of the following two areas:

- » Software Engineering
- » Computer Systems





**POSlijEDIPLOMSKI SVEUČILIŠNI (DOKTORSKI) STUDIJI IZ PODRUČJA TEHNIČKIH ZNANOSTI, POLJA STROJARSTVA, BRODOGRADNJE, TEMELJNIH TEHNIČKIH ZNANOSTI, INTERDISCIPLINARNIH TEHNIČKIH ZNANOSTI, ELEKTROTEHNIKE I RAČUNARSTVA**

Na Tehničkom fakultetu izvode se tri poslijediplomska sveučilišna (doktorska) studija iz tehničkih znanosti - polja strojarstva, brodogradnje, temeljnih tehničkih znanosti i interdisciplinarnih tehničkih znanosti, polja elektrotehnike te polja računarstva.

Završetkom ovih studija student stječe stupanj doktora znanosti što podrazumijeva superiorno poznavanje određenog znanstvenog područja unutar tehničkih znanosti i dokazanu sposobnost originalnog znanstvenog istraživanja. Njegove kompetencije obuhvaćaju vršno poznavanje literature i nerazjašnjenih problema iz određenog područja te sposobnost osmišljavanja i provođenja znanstvenoistraživačkog projekta do kraja, objavljivanja rezultata istraživanja te prezentiranja tih rezultata drugim znanstvenicima, izražavanja svojih stavova u prisutnosti eksperta u području (na kongresima, seminarima, gostovanjima na drugim institucijama itd.). Njegove osobine obuhvaćaju i želju za dijeljenjem svojega znanja i iskustva mlađim generacijama studenata, kritičnost, u prvom redu prema vlastitom istraživanju, ali i radu drugih te sposobnost prilagođavanja dolazećim promjenama.

Nakon završetka doktorskog studija otvaraju se brojne mogućnosti nastavka znanstveno-istraživačkog rada na matičnoj instituciji ili srodnim institucijama u Hrvatskoj ili inozemstvu, kao i postdoktorskog usavršavanja. Otvaraju se i mogućnosti zapošljavanja u javnom i privatnom sektoru, posebno u onim gospodarskim subjektima s kojima Fakultet ima razvijenu suradnju, ali i drugdje u Hrvatskoj i inozemstvu.

Doktorski studij sastoji se od:

- » provedbe znanstvenoistraživačkog rada pod nadzorom i uz pomoć mentora, odnosno sumentora koja rezultira izradom doktorskog rada (90 ECTS bodova),
- » polaganja obveznih i izbornih predmeta propisanih studijskim programom doktorskog studija (42 ECTS bodova),
- » boravka na drugim domaćim ili inozemnim sveučilišnim ili znanstvenim institucijama u trajanju od najmanje 3 mjeseca (20 ECTS bodova),
- » drugih aktivnosti koje obuhvaćaju prezentaciju znanstvenih rezultata na

**POSTGRADUATE DOCTORAL STUDIES IN THE FIELD OF ENGINEERING SCIENCES, IN THE SUBJECTS OF MECHANICAL ENGINEERING, NAVAL ARCHITECTURE, FUNDAMENTAL ENGINEERING SCIENCES, INTERDISCIPLINARY ENGINEERING SCIENCES, ELECTRICAL ENGINEERING AND COMPUTER SCIENCE**

At the Faculty of Engineering there are three postgraduate doctoral studies in the field of Engineering Sciences, first one in the subjects of Mechanical Engineering, Naval Architecture, Basic Engineering Sciences and Interdisciplinary Engineering Sciences; second one in the subject of Electrical Engineering, and the third one in the subject of Computer Science.

With the completion of the studies, the student gains the academic degree of Doctor of Science, has a superior knowledge of a particular scientific field within the engineering sciences and he will have proven to have the capability to and has proven to have original scientific research. His competences cover comprehension of literature and unsolved problems of a particular area and the ability to conduct a scientific project up to its completion, to publish the research results and to present these results to other scientists, the ability to express his opinion in the presence of experts in the research area (at conferences and similar gatherings). His characteristics include the desire to transfer his knowledge to the younger generations, criticism, in the first place towards his own work, but also towards the work of others and the ability to adapt to imminent changes.

Upon completion of the doctoral study, numerous possibilities for the continuation scientific work are present at the Faculty Engineering or other institutions in Croatia and abroad, as well as the possibility to continue education in postdoctoral study. Also, the possibility of finding an occupation in the public as well as in the private business sector becomes available (e.g., entities with whom the Faculty of Engineering has developed collaboration) as well as in other enterprises in Croatia and abroad.

The doctoral study consists of:

- » scientific research work under the guidance and help of a mentor and possibly a co-mentor, which results in the completion of a doctoral thesis (90 ECTS credits),
- » sitting examinations for all obligatory and elective courses prescribed by the curriculum of the doctoral study (42 ECTS credits),

domaćim i međunarodnim znanstvenim skupovima, objavljivanje znanstvenih radova (28 ECTS bodova).

Nastava doktorskog programa iz područja tehničkih znanosti, polja strojarstva, brodogradnje, temeljnih tehničkih znanosti i interdisciplinarnih tehničkih znanosti organizirana je u sedam modula:

1. Proizvodno strojarstvo
2. Termoeenergetika
3. Računarska mehanika
4. Projektiranje i gradnja plovniha objekata
5. Konstruiranje u strojarstvu
6. Osiguranje kvalitete i vođenje tehničkih sustava
7. Ekološko inženjerstvo i zaštita okoliša

Nastava doktorskog programa iz područja tehničkih znanosti, polja elektrotehnike organizirana je u dva modula:

1. Elektroničko-informacijski sustavi
2. Elektroenergetika i nove tehnologije

Nastava doktorskog programa iz područja tehničkih znanosti, polja računarstva organizirana je unutar modula Računarstvo.

» visiting other Croatian or foreign universities or scientific institutions in the duration of at least three months (20 ECTS credits),

» other activities that include the presentation of scientific research results at national or international scientific gatherings or the writing of scientific papers (28 ECTS credits).

The curriculum of the doctoral study the area of Engineering Sciences, in the fields of Mechanical Engineering, Naval Architecture, fundamental Engineering Sciences and Interdisciplinary Sciences comprises seven modules:

1. Production Technologies in Mechanical Engineering
2. Thermal Energy Engineering
3. Computational Mechanics
4. Design and Building of Naval Vessels
5. Mechanical Engineering Design
6. Quality Assurance and Technical System Management
7. Ecological Engineering and Environmental Protection

The curriculum of the doctoral study in the area of Engineering Sciences, in the field of Electrical Engineering comprises two modules:

1. Electronic and information systems
2. Power Engineering and New Technologies

The curriculum of the doctoral study in the area of Engineering Sciences, in the field of Computer Science comprises the module Computer Science.



Poslijediplomski sveučilišni (doktorski) studij							
Područje tehničke znanosti, polje strojarstva, brodaradnja, temeljne, tehničke znanosti i interdisciplinarne tehničke znanosti							
Metodologija znanstvenistraživačkog rada							
Matematičko modeliranje i numeričke metode							
Metode optimizacije							
Statističke metode i stohastički procesi							
Moduli	Proizvodno strojarstvo	Termoenergetika	Računarska mehanika	Projektiranje i gradnja plovih objekata	Konstruiranje u strojarstvu	Osiguranje kvalitete i vođenje tehničkih sustava	
Zajednički predmeti	Planiranje i vođenje proizvodnje	IP iz toplinskih znanosti	Elastomehanika i plastomehanika	Metodologija projektiranja plovih objekata	IP iz hidrostatičkih i pneumatskih prijenosa	Upravljanje kvalitetom	Ekološko inženjersvo i zaštita okoliša
	IP iz konvencionalne obrade odvajanjem čestica	Numeričko modeliranje prijelaza topline	MKE i optimizacija konstrukcija	Promotivnost i upravljivost plovih objekata	Modeliranje inženjerskih konstrukcija	Planiranje i vođenje proizvodnje	IP iz zaštite okoliša
	Definibilnost i suvremeno oblikovanje deformiranjem	Optimizacija energetskih procesa	Viskoelastičnost i viskoplastičnost	IP iz osnivanja plovih objekata	Nauka o konstruiranju	Statistička kontrola procesa	Opća ekologija
	IP iz nekonvencionalnih postupaka obrade	IP iz brodskih strojnih kompleksa	Stabilnost konstrukcija	Integrirana tehnologija gradnje broda	IP iz konstruktivskih elemenata	Projekiranje baze podataka	Zaštita mora i priobalja
	Razvojni i proizvodni menadžment	Termodinamička analiza procesa	Ne-linearna analiza konstrukcija	IP iz metodologije gradnje plovih objekata	Specijalni mehančki prijenosnici	Poslovno odlučivanje	Kemija okoliša
	CAM, CAP, CAD/NC-CIM	Eksplozivna metode u toplinskoj tehnici i termoenergetici	Kontaktna mehanika	IP iz otpora plovih objekata	Konstrukcija i optimizacija zupčastih prijenosnika	Modeli stohastičkih procesa informacija	Upravljanje održivim razvojem i zaštita okoliša
	Roboti i manipulatori	Termodinamička smjesa i toplinski uređaji	IP iz termomehanike	IP iz propulzije plovih objekata	IP iz transporthnih sredstava u industriji	Pouzdanost tehničkih sustava	Zaštita okoliša u energetici i procesnoj industriji
	IP iz fleksibilnih proizvodnih sustava	IP iz tehnike hlađenja i tehnike niskih temperatura	Vibracije i trajnost strojeva i konstrukcija	IP iz dinamike plovih objekata	Metoda rubnih elemenata	Inteligentni sustavi	Instrumentacija i analitičke teme u zaštiti okoliša
	Inteligentni proizvodni sustavi	IP iz izmjenjivača topline	Kinematika i dinamika robota	Projektiranje strukture plovih objekata	Kontaktni problemi u analizi konstrukcijskih elemenata	Mikroekonomija i konkurentnost	Okoliš i gospodarstvo
	Metode simulacije u proizvodnji	IP iz grijanja i klimatizacije	Zaštita od buke i vibracija strojeva i konstrukcija		Principi konstrukcija visokih i ultravisokih preciznosti	Inženjersvo kvalitete	Zaštita okoliša u tehnici hlađenja
	Mehanika prijeloma i umornjivost materijala	IP iz ispitivanja materijala	Dinamika fluida		Podatiji elementi i mehanizmi	Sigurnost tehničkih sustava	Fizika atmosfere
	Mehanika prijeloma i umornjivost materijala	IP iz ispitivanja materijala	Računarska mehanika fluida				
	Proces ostvarenja materijala	IP iz toplinskih turbostrojeva	Hidro dinamika turbostrojeva				
		IP iz brodskih energetskih postrojenja	Turbulentno strujanje				
			Modeliranje nestacionarnog strujanja u cevovodima				



Postgraduate University (Doctoral) Study							
Area of Engineering Sciences, Fields of Mechanical Engineering, Naval Architecture, Fundamental Engineering Sciences and Interdisciplinary Sciences							
Methodology of Scientific Work and Research							
Mathematical Modelling and Numerical Methods							
Optimization Methods							
Statistical Methods and Stochastic Processes							
Modules	Production Technologies in Mechanical Engineering	Thermal Energy Engineering	Computational Mechanics	Design and Building of Naval Vessels	Mechanical Engineering Design	Quality Assurance and Technical Systems Management	
Common courses	Planning and Processing of Manufacture	Selected Topics on Thermal Sciences	Elastomechanics and Plastomechanics	Methodology of Ship Design	Selected Chapters on Hydrostatics and Pneumatic Transmissions	Quality Management	Ecological Engineering and Environmental Protection
	Selected Chapters on Conventional Machining Processes	Numerical Modeling of Heat Transfer	FEM and Optimization of Structures	Seakeeping and Manoeuvrability	Modelling of Engineering Structures	Production Planning and Control	Selected Topics on Environment Protection
	Formability and Modern Forming Technology	Optimization of Energy Processes	Viscoelasticity and Viscoplasticity	Selected Topics in Ship Design	Design Science	Statistical Process Control	General Ecology
	Selected Chapters on Nonconventional Machining Processes	Selected Topics of Marine Machinery Systems	Structural Stability	Integrated ship Production Technology	Selected Chapters on Machine Elements	Design of Data Base	Protection of Sea and Coastal Zone
	Development and Operational Management	Thermodynamic Analysis of Processes	Nonlinear Structural Analysis	Selected Topics on Floating Objects Production Methodology	Special Mechanical Transmissions	Business Decision-making	Environmental Chemistry
	CAM, CAP, CAD/NC-CIM	Experimental Methods in Thermal and Power Engineering	Contact Mechanics	Selected Topics in Ship Resistance	Design and Optimization of Gear Transmissions	Models of Stochastic Information Processes	Management of Sustainable Development and Environmental Protection
	Robots and Manipulators	Thermodynamics of Mixtures and Thermal Devices	Advanced Thermomechanics	Selected Topics in Ship Propulsion	Selected Chapters on Power Transmission	Reliability of Technical Systems	Instrumentation and Analytical Techniques in Environment Protection
	Selected Chapters on Flexible Production Systems	Selected Chapters on Refrigeration and Low-Temperature Refrigeration	Vibrations and Durability of Machines and Structures	Selected Topics in Marine Dynamics	Selected Chapters on Industrial Transport Equipment and Devices	Intelligent Systems	Environment and Economics
	Intelligent Manufacturing Systems	Selected Chapters on Heat Exchangers	Kinematics and Dynamics of Robots	Ship Structural Design	Boundary Element Method	Microeconomics and Competitiveness	Environmental Refrigeration
	Simulation Methods in Production	Selected Chapters on Heating and Air Conditioning	Protection Against Noise and Vibrations of Machines and Structures		Contact Problems in Machine Elements Analyses	Quality Engineering	Physics of the atmosphere
	Processes Plans Optimization	Renewable Energy Sources	Fluid Dynamics		Principles of High and Ultra-high Precision Devices	Safety of Technical Systems	
	Selected Chapters on Material testing	Rational Energy Consumption	Computational Fluid Mechanics		Compliant Elements and Mechanisms		
	Heat Treatment and Surface Engineering	Numerical Modeling of Combustion Process	Hydrodynamics of Turbomachines				
	Material Chemistry	Selected Chapters on Internal Combustion Engines	Turbulent Flow				
	Corrosion and Metals Protection	Modern Engine Design	Unsteady Pipe Flow Modeling				
Fracture Mechanics and Fatigue of Materials	Durability and Reliability of Thermal Energy Systems						
Processes of Damaging of Materials	Selected Chapters on Thermal Turbomachines						
	Selected Chapters on Marine Energy Systems						

Poslijediplomski sveučilišni (doktorski) studij		
Područje tehničke znanosti, polje elektrotehnika		
Zajednički predmeti	Metodologija znanstvenoistraživačkog rada	
	Matematičko modeliranje i numeričke metode	
	Metode optimizacije	
	Statističke metode i stohastički procesi	
Moduli	Elektroničko-informacijski sustavi	Elektroenergetika i nove tehnologije
Predmeti po modulima	Analiza i obrada nestacionarnih signala	Modeli stohastičkih procesa informacija
	Elektromagnetsko modeliranje	Modeliranje sustava za distribuciju i potrošnju električne energije
	Fotoničke komponente	Pouzdanost tehničkih sustava
	Mjerenje i analiza kvalitete električne energije	Sustavi upravljanja sinkronim generatorima
	Mješovita obrada signala	Teorija informacija s primjenama
	Nelinearni sustavi automatskog upravljanja	Aktivne distribucijske mreže
	Ambijentalna inteligencija	Inteligentni elektroenergetski sustavi – Smart Grids
	Inteligentni sustavi	Izabrana poglavlja iz energetske komponenti i sustava obnovljivih izvora energije
	Projektiranje digitalnih sustava	Nova energetska paradigma
	Uslužna robotika	
	Uvod u meko računarstvo i primjene	

Poslijediplomski sveučilišni (doktorski) studij	
Područje tehničke znanosti, polje računarstvo	
Zajednički predmeti	Metodologija znanstvenoistraživačkog rada
	Matematičko modeliranje i numeričke metode
	Metode optimizacije
	Statističke metode i stohastički procesi
Moduli	Računarstvo
Predmeti po modulima	Teorija informacija s primjenama
	Primijenjeno strojno učenje
	Oblikovanje i vrednovanje naprednih interaktivnih sustava
	Odabrana poglavlja iz komunikacijskih mreža
	Računalna percepcija
	Nosivo računarstvo
	Inteligentni sustavi
	Uslužna robotika
	Uvod u meko računarstvo i primjene

Postgraduate University (Doctoral) Study		
Area of Engineering Sciences, Field of Electrical Engineering		
Common courses	Methodology of Scientific Work and Research	
	Mathematical Modelling and Numerical Methods	
	Optimization Methods	
	Statistical Methods and Stochastic Processes	
Modules	Electronic-Information Systems	Electric Power Systems and New Technologies
Module courses	Nonstationary Signal Analysis and Processing	Stochastic Information's Process Models
	Electromagnetic Modelling	Modelling of Electrical Power Distribution Systems
	Photonic Devices	Reliability of Technical Systems
	Measurement and Analysis of Electric Power Quality	Control of Synchronous Generators
	Mixed Signal Processing	Information Theory with Applications
	Nonlinear Control Systems	Active Distribution Networks
	Ambient Intelligence	Intelligent Power Systems - Smart Grids
	Intelligent Systems	Selected Chapters on Energy Components and Systems of Renewable Energy Sources
	Digital System Design	New Energy Paradigm
	Service Robotics	
	Introduction to Soft Computing and Applications	

Postgraduate University (Doctoral) Study	
Area of Engineering Sciences, Field of Computer Science	
Common courses	Methodology of Scientific Work and Research
	Mathematical Modelling and Numerical Methods
	Optimization Methods
	Statistical Methods and Stochastic Processes
Modules	Computer Science
Module courses	Information Theory with Applications
	Applied Machine Learning
	Advanced Interactive Systems Design and Evaluation
	Selected Chapters from Communication Networks
	Computer Perception
	Wearable Computing
	Intelligent Systems
	Service Robotics
	Introduction to Soft Computing and Applications



**PREDDIPLOMSKI STRUČNI STUDIJ STROJARSTVA**

Preddiplomski stručni studij strojarstva ima za cilj osposobljavanje stručnjaka strojarstva za rad na izvršavanju složenih operativnih poslova kod razrade projekata strojarstvenih konstrukcija, odnosno složenih operativnih poslova planiranja, pripreme, unapređenja i kontrole tehnoloških i proizvodnih procesa i planiranja, organiziranja i vođenja proizvodnih, odnosno energetskih postrojenja. Pri tome je njihovo radno mjesto prvenstveno u pogonu, odnosno terenu, a u manjoj mjeri u uredu.

Odluči li se student za nastavak studija, on će biti moguć na onim ustanovama koje nude diplomski stručni studij strojarstva. Također, bit će moguć nastavak na diplomskom sveučilišnom studiju strojarstva Tehničkog fakulteta Sveučilišta u Rijeci prema posebnim uvjetima upisa koje određuje Fakultetsko vijeće.

**PREDDIPLOMSKI STRUČNI STUDIJ BRODOGRADNJE**

Preddiplomski stručni studij brodogradnje ima za cilj osposobljavanje stručnjaka brodogradnje za rad na izvršavanju složenih operativnih poslova kod razrade projekata plovinih objekata i objekata morske tehnologije i njihovih elemenata, odnosno složenih operativnih poslova planiranja, pripreme, unapređenja i kontrole procesa gradnje plovinih objekata. Pri tome je njegovo radno mjesto prvenstveno u proizvodnji, a u manjoj mjeri u uredu.

Odluči li se student za nastavak studija, on će biti moguć na onim ustanovama koje nude diplomski stručni studij brodogradnje. Također, bit će moguć nastavak na diplomskom sveučilišnom studiju brodogradnje Tehničkog fakulteta Sveučilišta u Rijeci prema posebnim uvjetima upisa koje određuje Fakultetsko vijeće.

**PREDDIPLOMSKI STRUČNI STUDIJ ELEKTROTEHNIKE**

Preddiplomski stručni studij elektrotehnike ima za cilj osposobljavanje stručnjaka elektrotehnike za sudjelovanje u projektiranju i konstruiranju elemenata postrojenja, za ispitivanje i održavanje električnih strojeva i uređaja, elektroničkih industrijskih uređaja i uređaja industrijske automatizacije, te industrijskih i elektroenergetskih postrojenja. Pri tome je njegovo radno mjesto prvenstveno u pogonu, odnosno terenu, a u manjoj mjeri u uredu.

Odluči li se student za nastavak studija, on će biti moguć na onim ustanovama koje nude diplomski stručni studij elektrotehnike. Također, bit će moguć nastavak na diplomskom sveučilišnom studiju elektrotehnike Tehničkog fakulteta Sveučilišta u Rijeci prema posebnim uvjetima upisa koje određuje Fakultetsko vijeće.

**UNDERGRADUATE VOCATIONAL STUDY OF MECHANICAL ENGINEERING**

The aim of the undergraduate vocational study in Mechanical Engineering is to train experts in mechanical engineering to carry out complex operational tasks in technical systems projects, that is, complex operational tasks of planning, preparing, improving, and controlling technological and production processes, and planning, organising, and overseeing production and power facilities. The job position is primarily in the plant room, in the field, and to a lesser extent, in the office. If students decide to continue their studies, they can do this at those institutions offering graduate vocational study in mechanical engineering. In addition, they can continue their studies at the graduate university study of mechanical engineering at the Faculty of Engineering in Rijeka in line with special admission requirements set by the Faculty Council.

**UNDERGRADUATE VOCATIONAL STUDY OF NAVAL ARCHITECTURE**

The aim of the undergraduate vocational study in naval architecture is to train experts in naval architecture to carry out complex operational tasks in the projects of ships and marine technology objects and their elements, that is, complex operational tasks of planning, preparing, improving, and controlling the process of building ships. The job position is primarily in production and to a lesser extent in the office. If students decide to continue their studies, they can do this at those institutions offering graduate vocational study in naval architecture. In addition, they can continue their studies at the graduate university study of naval architecture at the Faculty of Engineering in Rijeka in line with special admission requirements set by the Faculty Council.

**UNDERGRADUATE VOCATIONAL STUDY OF ELECTRICAL ENGINEERING**

The aim of the undergraduate vocational study in electrical engineering is to train experts in electrical engineering to participate in designing and building plant parts, to inspect and maintain electrical machines and devices, electronic industrial devices and industrial automation devices, and industrial and electric power plants. The job position is primarily in the plant room, in the field, and to a lesser extent, in the office. If students decide to continue their studies, they can do this at those institutions offering graduate vocational study in electrical engineering. In addition, they can continue their studies at the graduate university study of electrical engineering at the Faculty of Engineering in Rijeka in line with special admission requirements set by the Faculty Council.

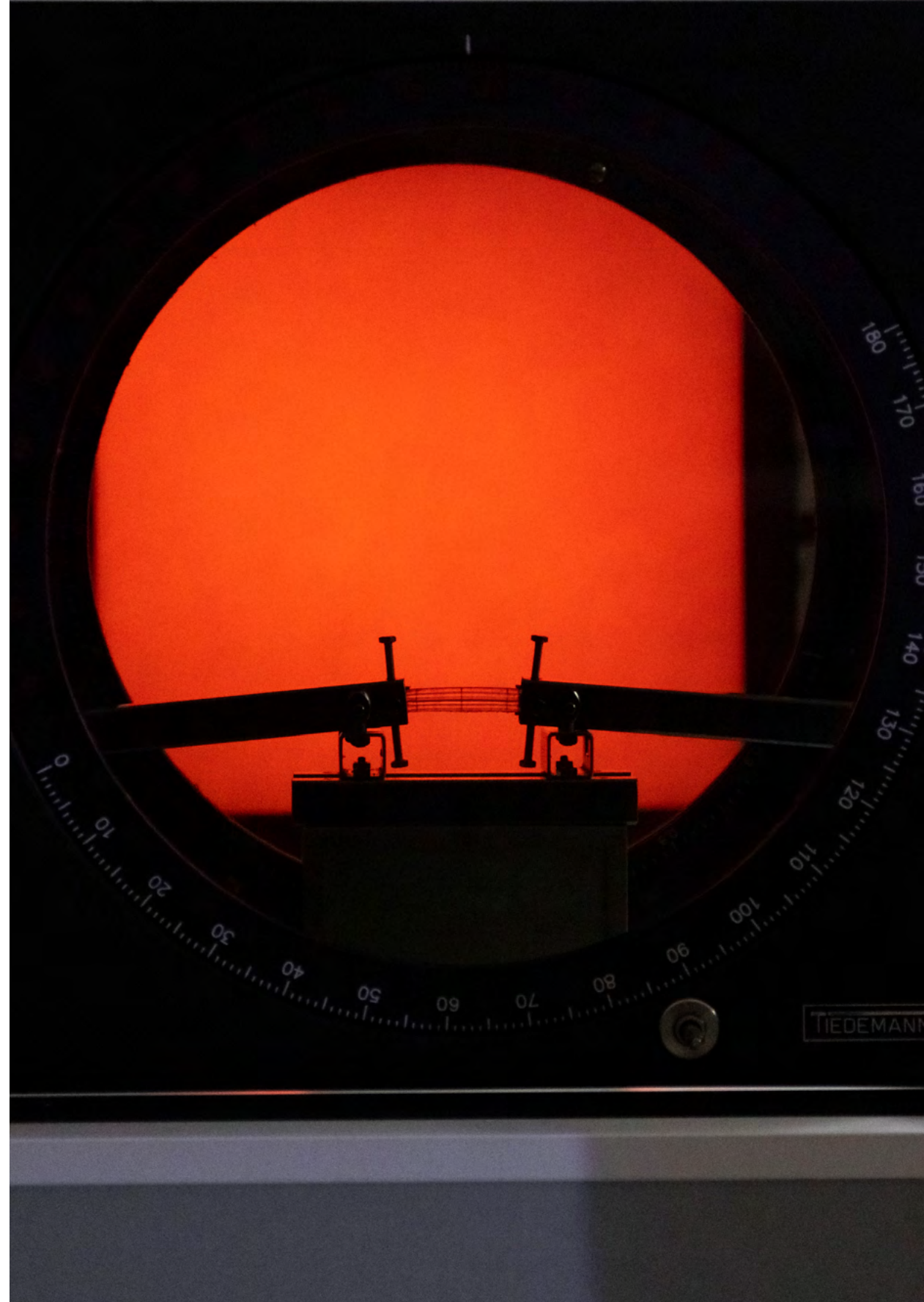



Prediplomski stručni studiji												
S	S			S			S			S		
	Strujarstvo	N	B	Predmet	N	B	Predmet	N	B	Predmet	N	B
I	Matematika I	5	7	I	Matematika I	5	7	I	Matematika I	5	7	
	Mehanika I	5	7		Mehanika I	5	7		Fizika	4	6	
	Materijali	4	6		Materijali	4	6		Osnove elektrotehnike ST I	5	8	
	Osnove elektrotehnike	3	5		Osnove elektrotehnike	3	5		Materijali i tehnološki postupci	3	4	
	Primjena računala ST	3	5		Primjena računala ST	3	5		Primjena računala ST	3	5	
	II	Matematika II	5	7	II	Matematika II	5	7	II	Matematika II	5	7
		Mehanika II	4	6		Mehanika II	4	6		Osnove elektrotehnike ST II	5	7
		Čvrstoća	4	6		Čvrstoća	4	6		Digitarna logika ST	4	6
		Tehničko crtanje	4	6		Tehničko crtanje	4	6		Mehanika i elementi konstrukcija ST	3	5
		Tehnologija obrade I	3	5		Plovnici objekti	3	5		Tehničko dokumentiranje	3	5
III		Organizacija i ekonomika	3	4	III	Organizacija i ekonomika	3	4	III	Mjerenja u elektrotehnici ST	5	7
		Mehanika fluida ST	3	5		Mehanika fluida ST	3	5		Elekt. komp. i osnovni sklopovi	5	7
		Toplina	4	6		Toplina	4	6		Linearne električne mreže	4	7
		Tehnologija obrade II	4	6		Brodске forme ST	4	7		Mehatronika	4	6
		Elementi strojeva I	4	6		Zavarivanje	3	5		Strani jezik I	2	3
	IV	Elementi strojeva II	4	6	IV	Hidrostatika broda	4	6	IV	Osnove energetske elektronike	5	7
		Obradni strojevi	3	5		Strukturni elementi broda	4	6		Osnove automatske regulacije	4	7
		Toplinski strojevi i uređaji I	3	5		Tehnologija brodogradnje I	3	5		Kolegij zbornе skupine	5	8
		Strani jezik II	2	3		Elementi strojeva I BG	3	5		Strani jezik II	2	3
		Stručna praksa I	5	5		Strani jezik II	2	3		Stručna praksa I	5	5
V		Kolegij zbornе skupine	4	6		Stručna praksa I	5	5				
		Mjerna tehnika ST	3	5	V	Mjerna tehnika ST	3	5	V	Organizacija i ekonomika	3	4
		Toplinski strojevi i uređaji II	3	5		Tehnologija brodogradnje II	5	6		Kolegij zbornе skupine	5	7
		Hidraulički strojevi	3	5		Tehn. procesi gradnje i remonta broda	5	6		Kolegij zbornе skupine	4	7
		Zavarivanje	3	5		Konstrukcija broda	4	6		Kolegij zbornе skupine	4	6
	VI	Kolegij zbornе skupine	4	5		Oprema broda ST	4	7		Kolegij zbornе skupine	4	6
		Slobodni kolegij	4	5	VI	Gradnja i održavanje malih plovnih objekata	4	5	VI	Slobodni kolegij	4	5
		Stručna praksa II	10	10		Slobodni kolegij	4	5		Stručna praksa II	10	10
		Kolegij zbornе skupine	4	5		Stručna praksa II	10	10		Kolegij zbornе skupine	4	5
		Završni rad	10	10		Završni rad	10	10		Završni rad	10	10

Undergraduate Vocational Studies												
S	S			S			S			S		
	Mechanical Engineering	N	B	Course	N	B	Course	N	B	Course	N	B
I	Mathematics I	5	7	I	Mathematics I	5	7	I	Mathematics I	5	7	
	Mechanics I	5	7		Mechanics I	5	7		Physics	4	6	
	Materials	4	6		Materials	4	6		Fundamentals of Electrical Engineering VO I	5	8	
	Fundamentals of Electrical Engineering	3	5		Fundamentals of Electrical Engineering	3	5		Materials and Production Processes	3	4	
	Applied Computing VO	3	5		Applied Computing VO	3	5		Applied Computing VO	3	5	
	II	Mathematics II	5	7	II	Mathematics II	5	7	II	Mathematics II	5	7
		Mechanics II	4	6		Mechanics II	4	6		Fundamentals of Electrical Engineering VO II	5	7
		Strength of Materials	4	6		Strength of Materials	4	6		Digital Logic VO	4	6
		Technical Drawing	4	6		Technical Drawing	4	6		Mechanics and Structural Elements VO	3	5
		Manufacturing Technology I	3	5		Marine Vessels	3	5		Technical Documenting	3	5
III		Organization and Economics	3	4	III	Organization and Economics	3	4	III	Measurements in Electrical Engineering VO	5	7
		Fluid Mechanics VO	3	5		Fluid Mechanics VO	3	5		Semiconductor Devices and Basic Microel. Circ	5	7
		Thermodynamics	4	6		Thermodynamics	4	6		Linear Electrical Circuits	4	7
		Manufacturing Technology II	4	6		Ship Hull Forms VO	4	7		Mechatronics	4	6
		Machine Elements I	4	6		Welding Engineering	3	5		Foreign Language I	2	3
	IV	Foreign Language I	2	3		Foreign Language II	2	3				
		Machine Elements II	4	6	IV	Ship Hydrostatics	4	6	IV	Fundamentals of Power Electronics	5	7
		Machine Tools	3	5		Ship Structure	4	6		Fundamentals of Automatic Regulation	4	7
		Heat Engines and Devices I	3	5		Shipbuilding Technology I	3	5		Elective group course	5	8
		Foreign Language II	2	3		Machine Elements I NA	3	5		Foreign Language II	2	3
V		Professional Practice I	4	6		Foreign Language II	2	3		Professional Practice I	5	5
		Elective group course	4	5		Professional Practice I	5	5				
		Measuring Technology VO	3	5	V	Measuring Technology VO	3	5	V	Organization and Economics	3	4
		Heat Engines and Devices II	3	5		Shipbuilding Technology II	5	6		Elective group course	5	7
		Hydraulic Machines VO	3	5		Techological Processes of Ship Production and Re	4	6		Elective group course	4	7
	VI	Welding Engineering	3	5		Ship Construction	4	6		Elective group course	4	6
		Elective group course	4	5		Ship Equipment VO	4	7		Elective group course	4	6
		Elective group course	4	5								
		Free Elective Course	4	5	VI	Small Craft Building and Maintenance	4	5	VI	Free Elective Course	4	5
		Professional Practice II	10	10		Free Elective Course	4	5		Professional Practice II	10	10
Elective group course		4	5		Professional Practice II	10	10		Elective group course	4	5	
Final Work		10	10		Final Work	10	10		Final Work	10	10	



Sveučilište u Rijeci, Tehnički fakultet  
University of Rijeka, Faculty of Engineering,  
Croatia

Vukovarska 58, 51000 Rijeka  
Hrvatska | Croatia

[www.riteh.uniri.hr](http://www.riteh.uniri.hr) | [dekanat@riteh.hr](mailto:dekanat@riteh.hr)



## PRODEKANI | VICE-DEANS:

prof. dr. sc. / Prof. D. Sc. **Anica Trp**  
nastava | academics

prof. dr. sc. / Prof. D. Sc. **Marina Franulović**  
znanstvena djelatnost | research activities

izv. prof. dr. sc. / Assoc. Prof. D. Sc. **Ivan Štajduhar**  
poslovni odnosi | business affairs

## DEKAN | DEAN:

prof. dr. sc. / Prof. D. Sc.  
**Duško Pavletić**

## POMOĆNICI DEKANA | DEAN'S ASSISTANTS:

izv. prof. dr. sc. / Assoc. Prof. D. Sc. **Neven Bulić**

izv. prof. dr. sc. / Assoc. Prof. D. Sc. **Marino Brčić**

## URED DEKANA | DEAN'S OFFICE:

**Sanja Prpić**, dipl. oec. / grad. economist  
voditeljica | head

**Tomo Vergić**, dipl. iur. / grad. law.  
glavni tajnik | secretary general

**Željka Gulić**, mag. oec  
tajnica prodekana | vice dean secretary



ZAVOD ZA AUTOMATIKU  
I ELEKTRONIKU

ZAVOD ZA  
BRODOGRADNJU  
I INŽENJERSTVO MORSKE  
TEHNOLOGIJE

ZAVOD ZA  
ELEKTROENERGIJU

ZAVOD ZA MATEMATIKU,  
FIZIKU, STRUKTURNU  
KINEZIOLOGIJU

ZAVOD ZA

ZAVOD ZA  
FIZIKU

**5** zavodi  
departments



146

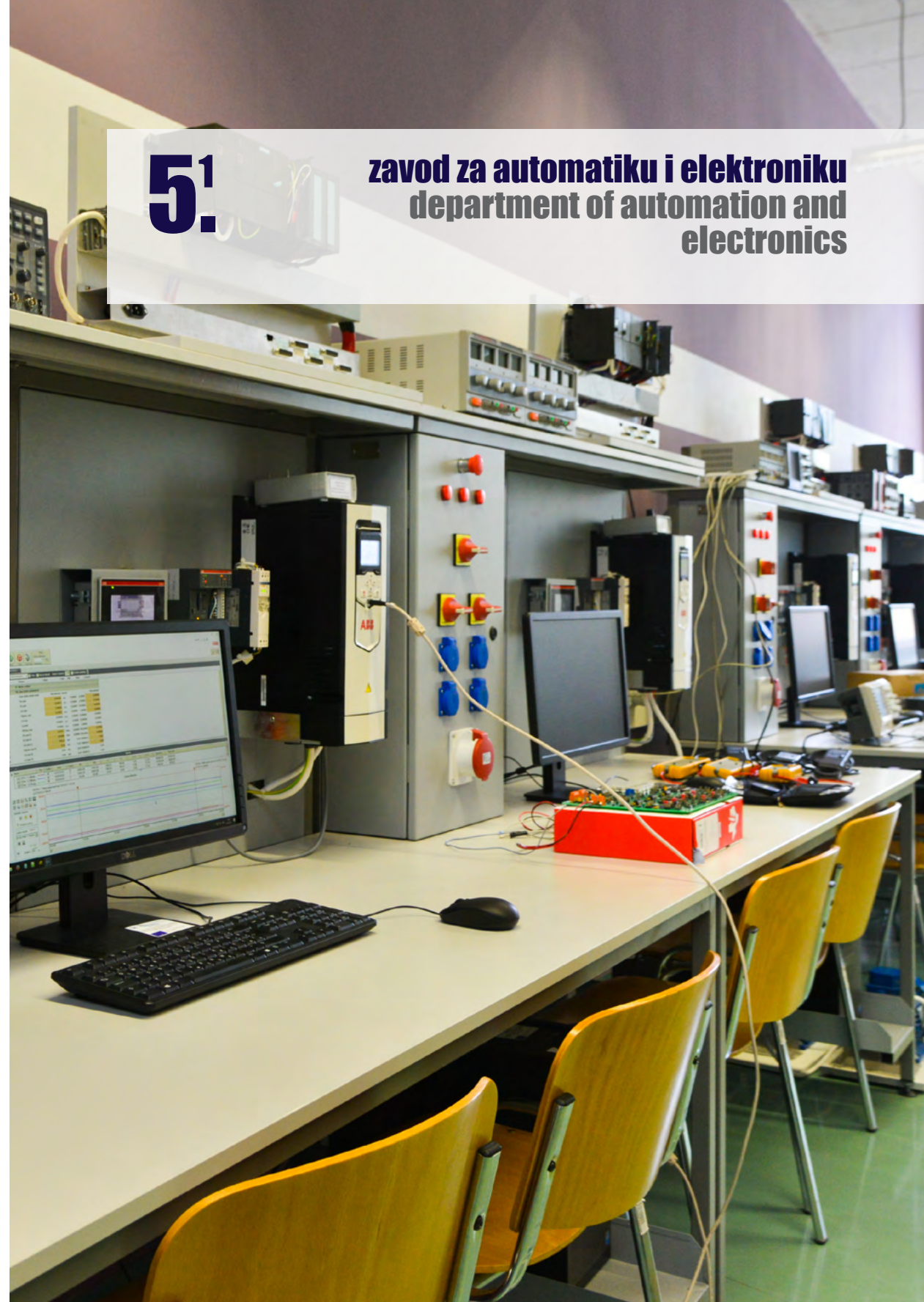

**5.**

**zavod za automatiku i elektroniku**  
department of automation and  
electronics



## djelatnici faculty and staff

### PREDSTOJNIK ZAVODA | DEPARTMENT HEAD:



Prof. dr. sc. / Prof. D. Sc. **Zlatan Car**

*umjetna inteligencija; inteligentni sustavi; robotika; CNC/NC obradni strojevi i robotika; konstrukcija i optimizacija alata i naprava; simulacija i optimizacija rada sustava i strojeva*  
*artificial intelligence; intelligent systems; CNC/NC machines & robotics; design of tools & fixtures; modeling, simulation and optimization of systems and machines*

### REDOVITI PROFESOR U TRAJNOM ZVANJU | TENURED PROFESSOR



**Nino Stojković**

*analogna obrada signala; analogni filtri*  
*analog signal processing; analog filters*

### REDOVITI PROFESORI | PROFESSORS



**Viktor Sučić**

*analiza i obrada signala*  
*signal analysis and processing*



**Saša Vlahinić**

*mjerenja u elektrotehnici; mjerenja kvalitete električne energije; elektronička i virtualna instrumentacija; obrada EEG signala; BCI*  
*electrical measurements; power quality measurements; electronic and virtual instrumentation; EEG signal processing; BCI*



**Miroslav Vrankić**

*digitalna obrada signala i slike; teorija valića; filtarski slogovi; asistivna tehnologija*  
*digital signal and image processing; wavelets and filter banks; assistive technology*

### IZVANREDNI PROFESORI | ASSOCIATE PROFESSORS

**Neven Bulić**

*automatizacija; elektromotorni pogoni; sustavi digitalnog upravljanja*  
*automation; electrical drives; digital control systems*



**Vera Gradišnik**

*poluvodička elektronika; optoelektronika; poluvodički elementi; fotosenzori iz amorfne silicija; tankoslojni fotosenzori u biotehnologiji; digitalna logika*  
*semiconductor electronics; optoelectronics; semiconductor devices; amorphous silicon photosensors; thin film photosensors in biotechnology; digital logic*



### DOCENT | ASSISTANT PROFESSOR

**Ivan Volarić**

*vremensko-frekvencijska obrada signala; obrada prorijeđenih signala*  
*time-frequency signal processing; sparse signal processing*



### ASISTENTI | ASSISTANTS

**Nikola Anđelić**

*automatika; umjetna inteligencija; molekularna dinamika; nanomehanika; analogna obrada signala*  
*automation, artificial intelligence, molecular dynamics, nanomechanics, analog signal processing*



**Sebastijan Blažević**

*automatika*  
*automation*



**Dominik Cikač**

*automatizacija; elektromotorni pogoni; sustavi digitalnog upravljanja*  
*automation; electrical drives; digital control systems*



**Vedran Jurdana**

*vremensko-frekvencijska obrada signala; statistička analiza signala*  
*time-frequency signal processing, statistical signal analysis*





**Nikola Lopac**

*elektromotorni pogoni; teorija upravljanja; automatizacija*  
*electric drives; control theory; automation*



**Ivan Lorencin**

*umjetna inteligencija; automatika; digitalna obrada slika*  
*artificial intelligence; automation; digital image processing*

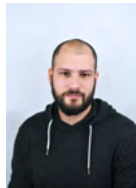

**Ivan Markovinović**

*obrada EEG signala; sučelje mozak-računalo; ICA*  
*EEG signal processing; brain-computer interface; ICA*



**Zoran Šverko**

*obrada EEG signala; neurofeedback*  
*EEG signal processing; neurofeedback*

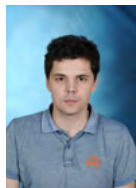

**Nikola Turk**

*automatika; upravljanje elektromotornim pogonima;*  
*bezležajni motori*  
*automation; control of electrical drives; bearingless drives*

**STRUČNI SURADNICI - MLADI ISTRAŽIVAČI | JUNIOR RESEARCHERS**



**Sandi Baressi Šegota**

*umjetna inteligencija; evolucijska robotika; znanost o podacima*  
*artificial intelligence; evolutionary robotics; data science*



**Jelena Musulin**

*umjetna inteligencija; digitalna obrada slika; znanost o podacima*  
*artificial intelligence; digital image processing; data science*



**Daniel Štifić**

*umjetna inteligencija; znanost o podacima; obrada signala*  
*artificial intelligence; data science; signal processing*

**VANJSKI SURADNICI | ASSOCIATES**

**Dario Matika**

Ministarstvo obrane  
*automatika*  
*automation*

*Nastava se izvodi iz područja automatike, robotike, elektronike, mjerenja u elektrotehnici, mjerne instrumentacije te obrade signala.*

*Program razlikovne edukacije za upis na diplomski sveučilišni studij elektrotehnike.*

**nastava i znanost**  
**education and science**

*Lectures in the field of automatic control, robotics, electronics, electrical measurements, instrumentation and signal processing.*

*Program of lifelong learning for admission to the graduate university study of electrical engineering.*

**KOLEGIJI NA PREDDIPLOMSKIM SVEUČILIŠNIM STUDIJIMA**

| UNDERGRADUATE UNIVERSITY COURSES

- |  |   |
|--|---|
| <ul style="list-style-type: none"> <li>• Automatizacija</li> <li>• Automatsko upravljanje</li> <li>• Digitalna logika</li> <li>• Električne mreže</li> <li>• Elektronika</li> <li>• Elektronika I</li> <li>• Elektronika II</li> <li>• Elementi automatizacije postrojenja</li> <li>• Mjerenja u elektrotehnici</li> <li>• Modeliranje i simuliranje sustava</li> <li>• Osnove regulacijske tehnike</li> <li>• Računalom podržana mjerenja</li> <li>• Signali i sustavi</li> <li>• Stručna praksa I</li> </ul> | <ul style="list-style-type: none"> <li>• Automation</li> <li>• Automatic Control</li> <li>• Digital Logic</li> <li>• Electrical Circuits</li> <li>• Electronics</li> <li>• Electronics I</li> <li>• Electronics II</li> <li>• Elements of Plant Automation</li> <li>• Electrical Measurements</li> <li>• System Modelling and Simulation</li> <li>• Basic of Automatic Control</li> <li>• Computer Aided Measurement</li> <li>• Signals and Systems</li> <li>• Industrial Practice I</li> </ul> |
|--|---|

**KOLEGIJI NA DIPLOMSKIM SVEUČILIŠNIM STUDIJIMA**

| GRADUATE UNIVERSITY COURSES

- |  |   |
|--|---|
| <ul style="list-style-type: none"> <li>• Analogna obrada signala</li> <li>• Asistivna tehnologija</li> <li>• Automatizacija postrojenja i procesa</li> <li>• Automatizirana instrumentacija</li> <li>• Digitalna obrada signala</li> <li>• Digitalna obrada slike</li> <li>• Industrijska robotika</li> <li>• Mehatronički sustavi</li> <li>• Optoelektronika</li> </ul> | <ul style="list-style-type: none"> <li>• Analog Signal Processing</li> <li>• Assistive Technology</li> <li>• Automation of Plants and Processes</li> <li>• Automatic Instrumentation</li> <li>• Digital Signal Processing</li> <li>• Digital Image Processing</li> <li>• Industrial robotics</li> <li>• Mechatronic Systems</li> <li>• Optoelectronics</li> </ul> |
|--|---|

- Osnove robotike
- Primjena umjetne inteligencije
- Sustavi digitalnog upravljanja
- Sustavi kontrole
- Stručna praksa II
- Evolucijska robotika
- Statistička analiza signala
- Fundamentals of Robotics
- AI Implementation
- Digital Control Systems
- Control Systems
- Industrial Practice II
- Evolutionary Robotics
- Statistical Signal Analysis

**KOLEGIJI NA PREDDIPLOMSKIM STRUČNIM STUDIJIMA**

## | UNDERGRADUATE VOCATIONAL COURSES

- Automatizacija ST
- Digitalna logika ST
- Elektroničke komponente i osnovni sklopovi
- Linearne električne mreže
- Mehatronika
- Mjerenja u elektrotehnici ST
- Osnove automatske regulacije
- Automation ST
- Digital Logic ST
- Semiconductors Devices and Basic Electronic Circuits
- Linear Electrical Circuits
- Mechatronics
- Electrical Measurements ST
- Fundamentals of Automatic Regulation

**KOLEGIJI NA POSLIJEDIPLOMSKIM (DOKTORSKIM) SVEUČILIŠNIM STUDIJIMA**

## | POSTGRADUATE UNIVERSITY (DOCTORAL) COURSES

- Analiza i obrada nestacionarnih signala
- Fotoničke komponente
- Mjerenje i analiza kvalitete električne energije
- Mješovita obrada signala
- Nelinearni sustavi automatskog upravljanja
- Ambijentalna inteligencija
- Projektiranje digitalnih sustava
- Pouzdanost tehničkih sustava
- Inteligentni proizvodni sustavi
- Roboti i manipulatori
- Nonstationary Signal Analysis and Processing
- Photonic Devices
- Measurement and Analysis of Electric Power Quality
- Mixed Signal Processing
- Nonlinear Control Systems
- Ambient Intelligence
- Digital System Design
- Reliability of Technical Systems
- Intelligent Manufacturing Systems
- Robots and Manipulators

**ZNANSTVENOISTRAŽIVAČKI RAD | SCIENTIFIC RESEARCH**

- Obrada signala  
Signal Processing
- Elektronika  
Electronics
- Mjerenje kvalitete električne energije  
Power quality measurements
- Robotika  
Robotics
- Umjetna inteligencija  
Artificial intelligence
- Automatizacija  
Automation
- Korištenje umjetne inteligencije u modeliranju utjecaja i širenja COVID-19  
Use of Artificial Intelligence in modeling the effects and spread of COVID-19
- Primjena umjetne inteligencije u medicini  
Application of Artificial Intelligence in medicine

**PROJEKTI | PROJECTS**

- CEEPUS; CIII-HR-0108-06-1112 - Concurrent Product and Technology Development - Teaching, Research and Implementation of Joint Programs Oriented in Production and Industrial Engineering ; (EU projekt mobilnosti/voditelj projekta); CEEPUS; CIII-HR-0108-06-1112 - Concurrent Product and Technology Development - Teaching, Research and Implementation of Joint Programs Oriented in Production and Industrial Engineering; (EU mobility project; project manager)
- CEEPUS; CIII-RO-0202-05-1112 - Implementation and utilization of e-learning systems in study area of production engineering in Central European Region; (EU projekt mobilnosti/suradnik na projektu) CEEPUS; CIII-RO-0202-05-1112 - Implementation and utilization of e-learning systems in study area of production engineering in Central European Region; (EU mobility project; associate member)
- CEEPUS; CIII-CZ-0201-04-1112 - Knowledge Bridge for Students and Teachers in Manufacturing Technologies; (EU projekt mobilnosti/suradnik na projektu) CEEPUS; CIII-CZ-0201-04-1112 - Knowledge Bridge for Students and Teachers in Manufacturing Technologies; (EU mobility project; associate member)
- CEEPUS; CIII-PL-0007-07-1112 - Modern Methods of the Constitution and Measurement of Geometrical Surface Structure; (EU projekt mobilnosti/suradnik na projektu) CEEPUS; CIII-PL-0007-07-1112 - Modern Methods of the Constitution and Measurement of Geometrical Surface Structure; (EU mobility project; associate member)
- C140.106, Razvoj posebnih konstrukcija motora sa magnetskim ležajevima, upravljačke i energetske elektronike te njihove aplikacije u industriji, Područje4 - Pogoni i aktuatori, Neven Bulić, Dominik Cikać, Nikola Turk, Nikola Lopac, 2014- (projekt Linz Center of Mechatronics, LCM GmbH), znanstvenoistraživački.  
C140.106, Bearingless Reluctance Slice Motors, Area4 - Drives and Actuators, Neven Bulić, Dominik Cikać, Nikola Turk, Nikola Lopac, 2014- (Linz Center of Mechatronics, LCM GmbH project) Research and scientific project.
- Q-grid, znanstveno-istraživački projekt financiran od strane industrije Danieli-Systec, Neven Bulić, Dominik Cikać, Nikola Turk, 2014-.  
Q-grid, R&D project financed by industry Danieli-Systec, Neven Bulić, Dominik Cikać, Nikola Turk, 2014-.
- Napredne metode i tehnologije u znanosti o podacima i kooperativnim sustavima (DATACROSS), Znanstveni centar izvrsnosti za znanost o podacima i kooperativne sustave, Sveučilište u Zagrebu, Zagreb, Hrvatska  
Advanced Methods and Technologies in Data Science and Cooperative Systems (DATACROSS), Centre of Research Excellence for Data Science and Advanced Cooperative Systems, University of Zagreb, Zagreb, Croatia
- Rekonstrukcija vremensko-frekvencijske distribucije iz komprimirano uzorkovane domene neodređenosti analiziranog signala, Sveučilište u Rijeci, Rijeka, Hrvatska  
Time-Frequency Distribution Reconstruction from the Signal Compressively Sensed Ambiguity Function, University of Rijeka, Rijeka, Croatia
- HAMAG-BICRO, Program provjere inovativnog koncepta, Sinergijski učinak neurofeedback-a i fotobiomodulacije, Vlahinić Saša, 2020.  
HAMAG-BICRO, Proof of Concept Programme, Synergistic effect of neurofeedback and photobiomodulation, Vlahinić Saša, 2020.
- Znanstvena potpora Sveučilišta u Rijeci, „Razvoj inteligentnog ekspertnog sustava za online dijagnostiku raka mokraćnog mjehura“, potpore 2018., Zlatan Car, Ivan Lorencin  
University of Rijeka Scientific Support, "Development of an intelligent expert system for online diagnosis of bladder cancer", grants 2018., Zlatan Car, Ivan Lorencin

- Erasmus + KA2 Call, Development and Implementation of System for Performance Evaluation for Serbian HEIS and Systems - PESHES, Multilateral International Project, Zlatan Car, Ivan Lorencin
- Erasmus + KA2 Call, Development and Implementation of System for Performance Evaluation for Serbian HEIS and Systems - PESHES, Multilateral International Project, Zlatan Car, Ivan Lorencin
- Centar Kompetencija za pametne gradove - CEKOM, SmartRI; SmartCity.4DII (KK.01.2.2.03.0004) Competence Center for Smart Cities - CEKOM, SmartRI; SmartCity.4DII (KK.01.2.2.03.0004)
- Centralna Europska inicijativa, "Use of Regressive Artificial Intelligence (AI) and Machine Learning (ML) Methods in Modelling of COVID-19 spread – COVIDAI" (305.6019-20) Central European initiative, "Use of Regressive Artificial Intelligence (AI) and Machine Learning (ML) Methods in Modelling of COVID-19 spread – COVIDAI" (305.6019-20)
- Razvojno-edukacijski centar za metalsku industriju – Metalska jezgra Čakovec Development and Educational Centre for the Metal Industry – Metal Centre Čakovec

## PUBLIKACIJE | PUBLICATIONS

## RADVI U ČASOPISIMA | JOURNAL PAPERS

- Car, Z.; Baressi Šegota, S.; Anđelić, N.; Lorencin, I.; Mrzljak, V. Modeling the Spread of COVID-19 Infection Using a Multilayer Perceptron, Computational and Mathematical Methods in Medicine, 1748-670X, 2020, 1-10, 2020, Egipat
- Baressi Šegota, S., Lorencin, I.; Musulin, J.; Štifanić, D.; Car, Z.; Frigate Speed Estimation Using CODLAG Propulsion System Parameters and Multilayer Perceptron Procjena, Naše more : znanstveni časopis za more i pomorstvo, 0469-6255, 67, 117-125, 2020, Hrvatska
- Baressi Šegota, S.; Štifanić, D.; Ohkura, K.; Car, Z.; Use of Artificial Neural Network for Estimation of Propeller Torque Values in a CODLAG Propulsion System, Pomorski zbornik - Journal of Maritime and Transportation Sciences, 0554-6397, 58, 25-35, 2020, Hrvatska
- Kocijel, L.; Poljak, I.; Mrzljak, V.; Car, Z. Energy Loss Analysis at the Gland Seals of a Marine Turbo-Generator Steam Turbine, Tehnički glasnik - Technical Journal, 1846-6168, 14, 19-26, 2020, Hrvatska
- Baressi Šegota, S.; Anđelić, N.; Lorencin, I.; Saga, M.; Car, Z., Path planning optimization of six-degree-of- freedom robotic manipulators using evolutionary algorithms, International journal of advanced robotic systems, 1729-8806, 17, 1-16, 2020, Engleska
- Lorencin, I.; Anđelić, N.; Španjol, J.; Car, Z., Using multi-layer perceptron with Laplacian edge detector for bladder cancer diagnosis, Artificial Intelligence in Medicine, 1873-2860, 102, 1-16, 2020, Engleska
- Lorencin, I.; Anđelić, N.; Mrzljak, V.; Car, Z., Multilayer Perceptron approach to Condition- Based Maintenance of Marine CODLAG Propulsion System Components, Pomorstvo : scientific journal of maritime research, 1332-0718, 33, 181-190, 2020, Hrvatska
- Baressi Šegota, S.; Lorencin, I.; Ohkura, K.; Car, Z., On the Traveling Salesman Problem in Nautical Environments: an Evolutionary Computing Approach to Optimization of Tourist Route Paths in Medulin, Croatia, Pomorski zbornik - Journal of Maritime and Transportation Sciences, 0554-6397, 57, 71-87, 2019, Hrvatska
- Mrzljak, V.; Anđelić, N.; Lorencin, I.; Car, Z. Analysis of Gas Turbine Operation before and after Major Maintenance, Pomorski zbornik - Journal of Maritime and Transportation Sciences, 0554-6397, 57, 57-70, 2019, Hrvatska
- Lorencin, I.; Anđelić, N.; Mrzljak, V.; Car, Z., Genetic Algorithm Approach to Design of Multi-Layer Perceptron for Combined Cycle Power Plant Electrical Power Output Estimation, Energies, 1996-1073, 12 1-26, 2019, Švicarska
- Medica-Viola, V.; Baressi Šegota, S.; Mrzljak, V.; Štifanić, D., Comparison of conventional and heat balance based energy analyses of steam turbine, Pomorstvo : scientific journal of maritime research, 1332-0718, 34, 74-85, 2020, Hrvatska

- Baressi Šegota, S.; Anđelić, N.; Kudláček, J.; Čep, R. Artificial neural network for predicting values of residuary resistance per unit weight of displacement, Pomorski zbornik - Journal of Maritime and Transportation Sciences, 0554-6397, 57, 9-22, 2019, Hrvatska
- Mrzljak, V.; Kudláček, J.; Begić- Hajdarević, Đ.; Musulin, J.; The Leakage of Steam Mass Flow Rate through the Gland Seals – Influence on Turbine Produced Power, Pomorski zbornik - Journal of Maritime and Transportation Sciences, 0554-6397, 58, 39-56, 2020, Hrvatska
- Medica-Viola, V.; Mrzljak, V.; Anđelić, N.; Jelić, M.; Analysis of Low-Power Steam Turbine With One Extraction for Marine Applications, Naše more : znanstveni časopis za more i pomorstvo 0469-6255, 67, 87-95, 2020, Hrvatska
- Štifanić, D.; Musulin, J.; Miočević, A.; Baressi Šegota, S.; Šubić, R.; Car, Z. Impact of COVID-19 on Forecasting Stock prices: An Integration of Stationary Wavelet Transform and Long Short-Term Memory Complexity, 1076-2787, 2020, 1-12, 2020, Egipat
- Mrzljak, V.; Blecich, P.; Anđelić, N.; Lorencin, I. Energy and Exergy Analyses of Forced Draft Fan for Marine Steam Propulsion System during Load Change, Journal of marine science and engineering, 2077-1312, 7, 1-26, 2019, Švicarska
- Lorencin, I.; Anđelić, N.; Baressi Šegota, S.; Štifanić, D.; Musulin, J.; Mrzljak, V.; Markova-Car, E.; Car, Z. Dataset Size-Based approach in Design of Artificial Neural Network for Breast Cancer Diagnosis, World of Health, 2623-5773, 3, 13-19 2020, Hrvatska
- Musulin, J.; Štifanić, D.; Lorencin, I.; Baressi Šegota, S.; Anđelić, N.; Borović, E.; Protić, A.; Car, Z. Comparison of Three Artificial Intelligence Algorithms for Sepsis Prediction, World of Health 2623-5773, 3, 20-25, 2020, Hrvatska
- Vlahinić, S.; Franković, D.; Komen, V.; Antonić, A. Reactive Power Compensation with PV Inverters for System Loss Reduction Energies, ISSN: 1996-1073, 12, 2019, Švicarska
- Vlahinić, S.; Batistić, L.; Jadav, G. M.; Vrankić, M. Brain Computer Interface Based Communicator for Persons in Locked-in State Informatica, ISSN: 0868-4952 30, (4), 781-798, 2019, Litva
- Jurdana V.; Volarić I.; Sučić V. The Local Renyi Entropy Based Shrinkage Algorithm for Sparse TFD Reconstruction, 2020 International Conference on Broadband Communications for Next generation Networks and Multimedia Applications (CoBCom), ISBN: 978-1-7281-7492-1, 108-115, 2020, Graz, Austria
- Vlahinić, S.; Šverko, Z.; Bačnar, D.; Bebić, L. Analyses of IR stimulation influence on EEG 2020 IEEE International Instrumentation and Measurement Technology Conference (I2MTC) ISSN: 2642-2077, 1-6, 2020, Dubrovnik, Croatia
- Turk N.; Bulić N.; Gruber W.; "Nonlinear Control of a Bearingless Flux-Switching Slice Motor With Combined Winding System", IEEE/ASME Transactions on Mechatronics, ISSN: 1083-4435 25, 152-163, 2019
- Lopac N.; Bulić N.; Vrkić N. Sliding Mode Observer-Based Load Angle Estimation for Salient-Pole Wound Rotor Synchronous Generators, Energies ISSN: 1996-1073, 12 (9), 1-22 2019 Švicarska
- Lopac N., Šegon G.; Bulić N. Application of a model-based design tool X2C in induction machine vector control, Engineering review, ISSN: 1849-0433, 39 (1), 90-104, 2019, Hrvatska

## MEĐUNARODNI KONGRESI | INTERNATIONAL CONGRESSES

- Prpić-Oršić, J.; Mrzljak, V.; Baressi Šegota, S.; Lorencin, I. Solver parameter influence on the results of multilayer perceptron for estimating power output of a combined cycle power plant V INTERNATIONAL SCIENTIFIC CONFERENCE - SUMMER SESSION - INDUSTRY 4.0 - 2020 - PROCEEDINGS, 5, 8-11, 2020, Varna, Bugarska

- Mrzljak, V.; Prpić-Oršić, J.; Poljak, I.; Baressi Šegota, S.; Exergy analysis of steam condenser at various loads during the ambient temperature change, *INTERNATIONAL SCIENTIFIC CONFERENCE MACHINES. TECHNOLOGIES. MATERIALS 2020 - Winter Session - PROCEEDINGS*, 14-17, 2020, Borovets, Bugarska
- Mrzljak, V.; Baressi Šegota, S.; Kocijel, L.; Prpić-Oršić, J. Energy (isentropic) analysis of three-cylinder steam turbine with re-heating, *INTERNATIONAL SCIENTIFIC CONFERENCE HIGH TECHNOLOGIES. BUSINESS. SOCIETY 2020 - VOLUME I "HIGH TECHNOLOGIES" - PROCEEDINGS*, 1, 29-32, 2020, Borovets, Bugarska
- Mrzljak, V.; Prpić-Oršić, J.; Musulin, J.; Štifanić, D. Energy and exergy analysis of deaerator from combined-cycle power plant, *INTERNATIONAL SCIENTIFIC CONFERENCE TECHNICS. TECHNOLOGIES. EDUCATION. SAFETY, 2020 - PROCEEDINGS - VOLUME 1 - TECHNICS AND TECHNOLOGY. INFORMATION TECHNOLOGY*, 1 5-8, 2020, Borovets, Bugarska
- Mrzljak, V.; Prpić-Oršić, J.; Medica- Viola, V.; Anđelić, N. The change in energy flow streams for main marine propulsion steam turbine at different loads, *XXVIII INTERNATIONAL SCIENTIFIC CONFERENCE - Trans & MOTAUTO 2020 - PROCEEDINGS*, 28, 8-11, 2020, Varna, Bugarska
- Mrzljak, V.; Prpić-Oršić, J.; Lorencin, I.; Anđelić, N. Thermodynamic analysis of three-cylinder steam turbine from combined cycle power plant, *INTERNATIONAL CONFERENCE TECHNICAL SCIENCES. INDUSTRIAL MANAGEMENT 2020 - PROCEEDINGS*, 23-26 2020, Borovets, Bugarska

#### MEĐUNARODNA SURADNJA | INTERNATIONAL COLLABORATIONS

- RMIT University, Melbourne, Australija, Australia
- University of Queensland, Brisbane, Australija, Australia
- Elektrotehnički fakultet, Univerzitet Crne Gore, Podgorica, Crna Gora, Montenegro
- University in Prague Faculty Mechanical Engineering University, Republika Češka, Czech Republic
- Tomas Bata University in Zlín, Republika Češka, Czech Republic
- Technical University in Ostrava, Republika Češka, Czech Republic
- Vienna University of Technology, Austrija, Austria
- University in Miskolc, Mađarska, Hungary
- Budapest University of Technology and Economics, Mađarska, Hungary
- University of Žilina, Slovačka, Slovakia
- Poznan University of Technology, Poljska, Poland
- Kielce University of Technology, Poljska, Poland
- University of Ljubljana, Slovenija, Slovenia
- University of Novi Sad, Srbija, Serbia
- North University of Baia Mare, Rumunjska, Romania
- University of Kragujevac, Srbija, Serbia
- Danieli Automation, Italija, Italy
- Texas Instruments, SAD, USA
- Linz Center of Mechatronics GmbH, Austrija, Austria
- Johannes Kepler Universität Linz, Austrija, Austria
- Hiroshima University, Japan, Japan

5<sup>2</sup>

**zavod za brodogradnju i inženjerstvo  
morske tehnologije**  
department of naval architecture and  
ocean engineering



## djelatnici faculty and staff

### PREDSTOJNIK ZAVODA | DEPARTMENT HEAD:



Prof. dr. sc. / Prof. D. Sc. **Roko Dejhalla**

*otpor i propulzija plovnih objekata; brodski propulzori; gradnja i održavanje malih plovnih objekata; projektiranje malih plovnih objekata*  
*ship resistance and propulsion; ship propulsion devices; small craft building and maintenance; small craft design*

### REDOVITI PROFESORI U TRAJNOM ZVANJU | TENURED PROFESSORS



**Jasna Prpić-Oršić**

*pomorstvenost; njihanje i opterećenje plovnih objekata na morskim valovima; modeliranje okoliša i okolišnih opterećenja; dinamika pomorskih objekata*  
*seakeeping; motions and sea loads of ships and off-shore structures; modeling of environment and environmental loads; marine structures dynamics*



**Albert Zamarin**

*konstrukcija broda; čvrstoća broda; strukturna analiza broda; opterećenje plovnih objekata na morskim valovima; projektiranje strukture plovnih objekata; konstrukcija malih plovnih objekata*  
*ship structure; ship strength; ship structural analysis; ship structural design; sea loads of ships and off-shore structures; small craft construction*

### IZVANREDNI PROFESORI | ASSOCIATE PROFESSORS



**Marko Hadjina**

*metodologija gradnje i opremanja plovnih objekata; tehnologija i organizacija brodogradnje; projektiranje tehnologije gradnje broda; računalno integrirana gradnja broda; simulacijsko modeliranje brodograđevnih procesa; osnivanje brodogradilišta i proizvodnih procesa; ugovaranje plovnih objekata.*  
*ship production methodology and outfitting; shipbuilding technology and organisation; ship construction technology design; computer integrated ship construction; shipyards' production processes simulation modelling; shipyard and production process design; market analysis; ship contracting.*

**Tin Matulja**  
*gradnja i opremanje plovnih objekata; tehnologija i organizacija brodogradnje; osnivanje brodogradilišta i proizvodnih procesa; oprema plovnih objekata*  
*ship production and outfitting; shipbuilding technology and organisation; shipyard and production process design; floating objects equipment and outfitting;*



### DOCENTI | ASSISTANT PROFESSORS

**Damir Kolić**  
*tehnologija i organizacija brodogradnje; vitka proizvodnja; tehnološki procesi i metodologija gradnje broda; IHOP, DFP, PWBS, grupna tehnologija; upravljanje projektima; rudarenje podacima*  
*shipbuilding technology and organisation; lean manufacturing; technological processes and methodology of shipbuilding; IHOP, DFP, PWBS, group technology; project management; data mining*



**Dunja Legović**  
*otpor i propulzija plovnih objekata; dinamika broda; brodski propulzori; pomorstvenost plovnih objekata; brodske forme; zaštita okoliša*  
*ship resistance and propulsion; ship dynamics; ship propulsion devices; seakeeping; ship hull forms; environment protection;*



**Anton Turk**  
*plovnost i stabilitet broda; brodske forme; hidrostatika broda; stabilitet broda u eksploataciji*  
*seaworthiness and stability; ship hull forms; ship hydrostatics; ship stability in exploitation*



**Marko Valčić**  
*dinamika i pomorstvenost plovnih objekata; objekti morske tehnologije; odobalne operacije; vođenje i upravljanje plovnim objektima; dinamičko pozicioniranje; autonomna navigacija;*  
*ship dynamics and seakeeping; ocean mobile and fixed structures; offshore operations; guidance and control of marine vehicles; dynamic positioning; autonomous navigation;*



### ASISTENT | ASSISTANT

**Davor Bolf**  
*konstrukcija broda; čvrstoća broda; strukturna analiza broda; konstrukcija malih plovnih objekata; kompozitni materijali u brodskim strukturama*  
*ship structure; ship strength; ship structural analysis; small craft construction; composite materials in ship structures*



### STRUČNI SURADNICI | ASSOCIATES

**Darin Majnarić**  
*EU projekti*  
*EU projects*







**Lino Josip Novak**

EU projekti  
EU projects



**Sara Volarić**

EU projekti - administratorica  
EU projects - administrator

**VANJSKI SURADNICI | ASSOCIATES**

**Mirela Marin**

Brodogradilište Viktor Lenac | Shipyard Viktor Lenac  
osnivanje plovni objekata  
ship design

**Ivan Margić**

School of Fish d.o.o.  
osnivanje plovni objekata  
ship design

**Alan Klanac**

as2con - Alveus d.o.o., Rijeka  
strukturna analiza broda  
ship structural analysis

**Branko Radil**

Hrvatski registar brodova | Croatian Register of Shipping  
konstrukcija broda  
ship structures

**nastava i znanost  
education and science**

Nastava iz područja: projektiranje plovni objekata, tehnologija i organizacija brodogradnje, konstrukcija plovni objekata, hidromehanika plovni objekata.

Program razlikovne edukacije za upis na diplomski sveučilišni studij brodogradnje.

Lectures in the field of: marine vessel design, technology and organization of shipbuilding, marine vessel construction, marine hydromechanics.

Program of lifelong learning for admission to the graduate university study of naval architecture.

**KOLEGIJI NA PREDDIPLOMSKIM SVEUČILIŠNIM STUDIJIMA**

| UNDERGRADUATE UNIVERSITY COURSES

- |  |  |
|--|--|
| <ul style="list-style-type: none"> <li>• Brodske forme</li> <li>• Gradnja i održavanje malih plovni objekata SV</li> <li>• Hidrodinamika plovni objekata I</li> <li>• Konstrukcija broda I</li> <li>• Konstrukcija broda II</li> <li>• Oprema broda</li> <li>• Osnove dinamike broda</li> <li>• Osnove gradnje broda</li> <li>• Plovnost i stabilitet broda</li> <li>• Stručna praksa I</li> <li>• Tehnologija brodogradnje</li> <li>• Tehnološki procesi brodogradnje</li> <li>• Uvod u plovne objekte</li> </ul> | <ul style="list-style-type: none"> <li>• Ship Hull Forms</li> <li>• Small Craft Building and Maintenance UN</li> <li>• Marine Hydrodynamics I</li> <li>• Ship Structure I</li> <li>• Ship Structure II</li> <li>• Ship Equipment</li> <li>• Basic Ship Dynamics</li> <li>• Basics of Ship Production</li> <li>• Seaworthiness and Stability of the Ship</li> <li>• Industrial practice I</li> <li>• Shipbuilding Technology</li> <li>• Technology Processes of Shipbuilding</li> <li>• Introduction to Marine Vessels</li> </ul> |
|--|--|

- |   |   |
|---|---|
| <ul style="list-style-type: none"> <li>• Uvod u vođenje i upravljanje plovni objektima</li> </ul> | <ul style="list-style-type: none"> <li>• Introduction to guidance and control of marine vehicles</li> </ul> |
|---|---|

**KOLEGIJI NA DIPLOMSKIM SVEUČILIŠNIM STUDIJIMA**

| GRADUATE UNIVERSITY COURSES

- |   |  |
|---|--|
| <ul style="list-style-type: none"> <li>• Brodski propulzori</li> <li>• Osnivanje brodogradilišta</li> <li>• Čvrstoća broda</li> <li>• Dinamika pomorskih konstrukcija</li> <li>• Hidrodinamika plovni objekata II</li> <li>• Konstrukcija malih plovni objekata</li> <li>• Metodologija gradnje plovni objekata</li> <li>• Objekti morske tehnologije</li> <li>• Odobalne operacije</li> <li>• Oprema malih plovni objekata</li> <li>• Opremanje i remont broda</li> <li>• Organizacija i poslovanje brodogradilišta</li> <li>• Osnivanje plovni objekata I</li> <li>• Osnivanje plovni objekata II</li> <li>• Pomorstvenost plovni objekata</li> <li>• Projektiranje malih plovni objekata</li> <li>• Stabilitet broda u eksploataciji</li> <li>• Stručna praksa II</li> <li>• Strukturna analiza broda</li> <li>• Tehnološki proces gradnje broda</li> <li>• Ugovaranje plovni objekata</li> <li>• Upravljanje projektima u brodogradnji</li> </ul> | <ul style="list-style-type: none"> <li>• Ship Propulsion Devices</li> <li>• Shipyard Design</li> <li>• Ship Strength</li> <li>• Dynamics of Off Shore Structures</li> <li>• Marine Hydrodynamics II</li> <li>• Small Craft Construction</li> <li>• Methodology of Ship Production</li> <li>• Offshore structures and vehicles</li> <li>• Offshore operations</li> <li>• Small Crafts Equipment</li> <li>• Ship Outfitting and Repair</li> <li>• Shipyards Organisation and Management</li> <li>• Ship Design I</li> <li>• Ship Design II</li> <li>• Seakeeping</li> <li>• Small Craft Design</li> <li>• Ship Stability in Exploitation</li> <li>• Industrial practice II</li> <li>• Ship Structural Analysis</li> <li>• Technological Process of Shipbuilding</li> <li>• Ship Negotiation Process</li> <li>• Project Management in Shipbuilding</li> </ul> |
|---|--|

**KOLEGIJI NA PREDDIPLOMSKIM STRUČNIM STUDIJIMA**

| UNDERGRADUATE VOCATIONAL COURSES

- |   |  |
|---|--|
| <ul style="list-style-type: none"> <li>• Brodske forme ST</li> <li>• Gradnja i održavanje malih plovni objekata</li> <li>• Hidrostatika broda</li> <li>• Konstrukcija broda</li> <li>• Oprema broda ST</li> <li>• Osnivanje plovni objekata</li> <li>• Plovni objekti</li> <li>• Stručna praksa I</li> <li>• Stručna praksa II</li> <li>• Strukturni elementi broda</li> <li>• Tehnologija brodogradnje I</li> <li>• Tehnologija brodogradnje II</li> <li>• Tehnološki procesi gradnje i remonta broda</li> </ul> | <ul style="list-style-type: none"> <li>• Ship Hull Forms VO</li> <li>• Small Craft Building and Maintenance</li> <li>• Ship Hydrostatics</li> <li>• Ship Construction</li> <li>• Ship Equipment ST</li> <li>• Ship Design</li> <li>• Marine Vessels</li> <li>• Professional practice I</li> <li>• Professional practice II</li> <li>• Ship Structure</li> <li>• Shipbuilding Technology I</li> <li>• Shipbuilding Technology II</li> <li>• Technological Processes of Shipbuilding and Repair</li> </ul> |
|---|--|

**KOLEGIJI NA POSLIJEDIPLOMSKIM (DOKTORSKIM) SVEUČILIŠNIM STUDIJIMA**

| POSTGRADUATE UNIVERSITY (DOCTORAL) COURSES

- |  |   |
|--|---|
| <ul style="list-style-type: none"> <li>• Integralna tehnologija gradnje broda</li> <li>• Izabrana poglavlja iz metodologije gradnje plovni objekata</li> <li>• Metodologija projektiranja plovni objekata</li> <li>• Izabrana poglavlja iz osnivanja plovni objekata</li> <li>• Pomorstvenost i upravljivost plovni objekata</li> <li>• Izabrana poglavlja iz dinamike plovni objekata</li> <li>• Izabrana poglavlja iz otpora plovni objekata</li> <li>• Izabrana poglavlja iz propulzije plovni objekata</li> <li>• Projektiranje strukture plovni objekata</li> </ul> | <ul style="list-style-type: none"> <li>• Integrated Ship Production Technology</li> <li>• Selected Topics in Floating Objects Production Methodology</li> <li>• Methodology of Ship Design</li> <li>• Selected Topics in Ship Design</li> <li>• Seakeeping and Manoeuvrability</li> <li>• Selected Topics in Marine Dynamics</li> <li>• Selected Topics in Ship Resistance</li> <li>• Selected Topics in Ship Propulsion</li> <li>• Ship Structural Design</li> </ul> |
|--|---|



## Znanstvenoistraživački rad | Scientific Research

- **Hidrodinamičko opterećenje i odziv pomorskih objekata na morskim valovima**  
*Hydrodynamic loads and response of marine objects*
- **Projektiranje strukture broda, nove tehnologije kod projektiranja i preinaka brodskih konstrukcija, tehnološkičnost kod projektiranja i izrade brodskih konstrukcija**  
*Ship structural design, new technologies in ship structural design and conversions, technologicality in ship structure design and construction*
- **Otpor i propulzija plovnih objekata, hidrodinamičke optimizacije**  
*Ship resistance and propulsion, hydrodynamic optimizations*
- **Primjena naprednih tehnologija i metoda gradnje i opremanja plovnih objekata; organizacija brodograđevnog poslovnog i proizvodnog procesa; osnivanje i unapređenje brodograđilišta i proizvodnih procesa, primjena simulacijskog modeliranja, višekriterijskog odlučivanja i LEAN metodologije za unapređenje brodograđevnog procesa, analiza tržišta; ugovaranje i tehnološko prognoziranje**  
*Application of advanced technology and methods in ship construction and outfitting; organization of shipbuilding business and production process, the establishment and improvement of the shipyards and manufacturing processes, the application of simulation modeling, multicriteria decision making and LEAN methodologies to improve the shipbuilding process, market analysis, contracting and technological forecasting*
- **Primjena kompozitnih materijala na pomorskim konstrukcijama, analiza sudara malih kompozitnih plovila**  
*Application of composite materials on marine structures, Small composites crafts collision analysis*
- **Utjecaj opterećenja okoliša na značajke sustava dinamičkog pozicioniranja plovnih objekata**  
*The impact of environmental loads on the characteristics of dynamic positioning systems for marine vessels*

## Projekti | Projects

- **Nesigurnosti procjene brzine broda u pri realnim vremenskim uvjetima, uniri-tehnic-18-18 1146, Sveučilište u Rijeci, Jasna Prpić-Oršić, 2018. -, znanstvenoistraživački**  
*Uncertainties of ship speed loss evaluation under real weather conditions, uniri-tehnic-18-18 1146, University of Rijeka, Jasna Prpić-Oršić, 2018.-, research and scientific project*
- **Sustav potpore odlučivanju za zeleniju i sigurniju plovidbu brodova (DESSERT) IP-2018-01-3739, Hrvatska zaklada za znanost, Jasna Prpić-Oršić, 2018-2022, znanstvenoistraživački**  
*DEcision Support System for green and safe ship Routing (DESSERT) IP-2018-01-3739, Croatian Science Foundation, Jasna Prpić-Oršić, 2018-2022*
- **Unapređenje metodologije projektiranja i gradnje broda prema konceptu Industrija 4.0; Potpora znanstvenim istraživanjima za 2018. g. Sveučilišta u Rijeci, Voditelj istraživačkog tima: prof. dr. sc. Albert Zamarin, dipl. ing., 2018.-2021.**  
*Development of Methodology for Ship Design and Production towards Industry 4.0. Concept; Support for scientific research in 2018., University of Rijeka, Head of the research team: prof. dr. sc. Albert Zamarin, 2018.-2021.*
- **Utjecaj opterećenja okoliša na značajke sustava dinamičkog pozicioniranja plovnih objekata. Šifra projekta: uniri-tehnic-18-266. Financiranje: Sveučilište u Rijeci. Voditelj: Marko Valčić. Trajanje: 2018.-2020. Vrsta projekta: znanstveno-istraživački projekt.**  
*"The impact of environmental loads on the characteristics of dynamic positioning systems for marine vessels. Project ID: uniri-tehnic-18-266. Funding: University of Rijeka. Head: Marko Valčić. Period: 2018-2020. Project type: research project."*

- **Maritime Environment-friendly TRanspOrt systems (METRO), 2014-2020 Interreg V-Altaly - Croatia CBC Programme, razdoblje: 01.01.2019.- 30.06.2021., voditelj (Riteh): prof. dr. sc. Roko Dejhalla**  
*Maritime Environment-friendly TRanspOrt systems (METRO), 2014 - 2020 Interreg V-A Italy - Croatia CBC Programme, period: January 1, 2019.- June 30, 2021, head (Riteh): prof. Roko Dejhalla*
- **Vitka analiza proizvodnih procesa brodograđilišta, Inicijalne potpore mladim istraživačima Sveučilišta u Rijeci, URBROJ: 2170-57-08-18-27, Damir Kolić, 2018.**  
*Lean analysis of shipyard production processes, Initial grant to young researchers, University of Rijeka, No. 2170-57-08-18-27, Damir Kolić, 2018.*

## Publikacije | Publications

## Knjige | Books

- **Valčić, M.; Prpić-Oršić, J.; Vučinić, D.** "Application of Pattern Recognition Method for Estimating Wind Loads on Ships and Marine Objects. In: Vučinić, D., Rodrigues Leta, F., Janardhanan, S. (Eds.), *Advances in Visualization and Optimization Techniques for Multidisciplinary Research - Trends in Modelling and Simulations for Engineering Applications.*" Springer Nature Switzerland AG, "ISSN 2195-4356 (print), ISSN 2195-4364 (electronic), ISBN 978-981-13-9806-3", 2020 Singapore, Poglavlje u knjizi.

## Radovi u časopisima | Journal Papers

- **Bolf, D.; Hadjina, M.; Matulja, T.; Knapić, I.** *Implementation of Advanced Collaborative Platform for Project Based Learning in Naval Architecture Studies Journal of Maritime and Transportation Science, ISSN 0554-6397, Special Edition, 217-226, 2020, Rijeka, Hrvatska*
- **Bolf, D.; Zamarin, A.; Basan, R.** *Composite Material Damage Processes, Journal of Maritime and Transportation Science, ISSN 0554-6397, Special Edition, 307-323, 2020, Rijeka, Hrvatska*
- **Majnarić, D.; Zamarin, A.** *Stiffness Adjustment of Surface-Piercing Hydrofoils Within Fluid-Structure Interaction, Journal of Maritime & Transportation Sciences, ISSN 0554-6397, Special Edition, 189-204, 2020, Rijeka, Hrvatska*
- **Novak, L. J.; Majnarić, D.; Dejhalla, R.; Zamarin, A.** *An Analysis of Basic Parameters of Ro-Pax Ships and Double-ended Ferries as Basis for New Hybrid Ferries Design, Journal of Maritime & Transportation Sciences (Pomorski zbornik), ISSN 0554-6397, Special Edition, 33-48, 2020, Rijeka, Hrvatska*
- **Novak, L. J.; Dejhalla, R.** *Preliminary Design of a Drinking-water Carrier for Water Supply to the Croatian Islands, Journal of Maritime & Transportation Sciences (Pomorski zbornik), ISSN 0554-6398, Special Edition, 63-75, 2020, Rijeka, Hrvatska*
- **Parunov, J.; Čorak, M.; Guedes Soares, C.; Jafaryeganeh, H.; Kalske, S.; Shukui Liu, Papanikolaou, A.; Prentice, D.; Prpić-Oršić, J.; Ruponen, P.; Vitali, N.** *Benchmark study and uncertainty assessment in numerical predictions of global wave loads in damaged ships Ocean Engineering, ISSN 0029-8018, 197(106876), 2020, Oxford, United Kingdom, USA*
- **Mauro, F.; Prpić-Oršić, J.** *Determination of a DP operability index for an offshore vessel in early design stage, Ocean Engineering, ISSN 0029-8018, 195(106764), 2020, Oxford, United Kingdom, USA*
- **Vitali, N.; Prpić-Oršić, J.; Guedes Soares, C.** *Coupling voyage and weather data to estimate speed loss of container ships in realistic conditions, Ocean Engineering, ISSN 0029-8018 210(106758), 2020, Oxford, United Kingdom, USA*
- **Prpić-Oršić, J.; Sasa, K.; Valčić, M.; Faltinsen, O.M.** *Energy efficiency of ship under real weather conditions, Journal of Offshore Mechanics and Arctic Engineering, ISSN 0892-7219, 142(3), 2020, New York, USA*

- Chen C., Sasa, K.; Ohsawa, T.; Prpić-Oršić, J. Comparative study on WRF model simulations from the viewpoint of optimum ship routing, *Ocean Engineering*, ISSN 0029-8018, 207(107379), 2020, Oxford, United Kingdom, USA
- Chen, C.; Sasa, K.; Ohsawa, T.; Kashiwagi, M.; Prpic-Orsic, J.; Mizojiri, T. Comparative assessment of NCEP and ECMWF global datasets and numerical approaches on rough sea ship navigation based on numerical simulation and shipboard measurements *Applied Ocean Research*, ISSN 0141-1187, 101(102219), 2020, Oxford, United Kingdom, USA
- Prpić-Oršić, J.; Valčić, M.; Čarija, Z. A Hybrid Wind Load Estimation Method for Container Ship Based on Computational Fluid Dynamics and Neural Networks, *Journal of Marine Science and Engineering*, ISSN 2077-1312, 8(539), 2020, Basel, Switzerland
- Žgomba, D.; Turk, D.; Hadjina, M.; Pražić, D.; Margić, I. Longitudinal Ship Launching, *Pomorski zbornik Vol.Special edition No.2*, ISSN 0554-6397, 1, 239-250, 2020, Rijeka
- Staničić, T.; Toman Fernandez, M.; Turk, A.; Kolić, D. Foran Application on Damage Stability Assessment on a Container Vessel, *Pomorski zbornik Vol.Special edition No.2*, ISSN 0554-6397 1, 227-238, 2020, Rijeka
- Hadžić, N.; Keran, Z.; Hadjina, M.; Osmak, F. Analysis of elastic-plastic steel plates forming based on typical shipyard's roller bending machine, *Ocean Engineering*, ISSN: 0029-8018, <https://doi.org/10.1016/j.oceaneng.2019.106438>, 190, 1-32, 2019, Oxford, United Kingdom, USA
- Gaiotti, M.; Zamarin, A.; Josefson, L.; Matulja, T. A numerical sensitivity analysis on the cohesive parameters of a carbon-steel single lap joint, *Ocean Engineering*, ISSN: 00298018, 198, 1-10, 2020, Oxford, United Kingdom, USA
- Rudan, I.; Frančić, V.; Valčić, M.; Sumner, M. Early Detection of Vessel Collision Situations in a VTS Area, *Transport*, ISSN1648-4142, 35 (2), 121-132, 2020, Vilnius, Lithuania
- Valčić, M.; Prpić-Oršić, J. Derivative Free Optimal Thrust Allocation in Ship Dynamic Positioning Based on Direct Search Algorithms, *TransNav*, ISSN 2083-6473, 14 (2), 309-314, 2020, Gdynia, Poland
- Prpić-Oršić, J.; Sasa, K.; Valčić, M.; Faltinsen, O. M. Uncertainties of ship speed loss evaluation under real weather conditions, *Journal of Offshore Mechanics and Arctic Engineering - Transactions of the ASME*, ISSN 0892-7219, 142 (3), 031106, 5, 2020, New York, USA
- Brčić, D.; Filjar, R.; Kos, S.; Valčić, M. On Global Ionospheric Maps based Winter-time GPS Ionospheric Delay with Reference to the Klobuchar Model: Case Study of the Northern Adriatic. *Pomorstvo: Scientific Journal of Maritime Research*, ISSN 1332-0718, 33 (2), 210-221, 2019 Rijeka, Hrvatska
- Farkas, A.; Degiuli, N.; Martić, I.; Dejhalla, R. Impact of hard fouling on the ship performance of different ship forms, *Journal of Marine Science and Engineering (ISSN 2077-1312)* 2020, 8(10), 748; <https://doi.org/10.3390/jmse8100748>, September 2020
- Vilotijević, A.; Matulja, T.; Hadjina, M.; Bolf, D. Modern Equipment for Waste Management on Cruise Ships, *Journal of Maritime and Transportation Sciences*, ISSN 0554-6397, Special Edition, 147-156, 2020, Rijeka

#### MEĐUNARODNI KONGRESI | INTERNATIONAL CONGRESSES

- Bolf, D.; Hadjina, M.; Matulja, T.; Knapić, I. Implementation of Advanced Collaborative Platform for Project Based Learning in Naval Architecture Studies, 8th INTERNATIONAL CONFERENCE ON MARINE TECHNOLOGY-in memoriam academician Zlatko Winkler, 2019, Rijeka, Hrvatska
- Bolf, D.; Zamarin, A.; Basan, R. Composite Material Damage Processes, 8th INTERNATIONAL CONFERENCE ON MARINE TECHNOLOGY-in memoriam academician Zlatko Winkler, 2019, Rijeka, Hrvatska

- Majnarić, D.; Zamarin, A. Stiffness Adjustment of Surface-Piercing Hydrofoils Within Fluid-Structure Interaction, 8th INTERNATIONAL CONFERENCE ON MARINE TECHNOLOGY-in memoriam academician Zlatko Winkler, 2019, Rijeka, Hrvatska
- Novak, L. J.; Majnarić, D.; Dejhalla, R.; Zamarin, A. An Analysis of Basic Parameters of Ro-Pax Ships and Double-ended Ferries as Basis for New Hybrid Ferries Design, 8th INTERNATIONAL CONFERENCE ON MARINE TECHNOLOGY-in memoriam academician Zlatko Winkler, 2019 Rijeka, Hrvatska
- Novak, L. J.; Dejhalla, R. Preliminary Design of a Drinking-water Carrier for Water Supply to the Croatian Islands, 8th INTERNATIONAL CONFERENCE ON MARINE TECHNOLOGY-in memoriam academician Zlatko Winkler, 2019, Rijeka, Hrvatska
- Vilotijević, A.; Matulja, T.; Hadjina, M.; Bolf, D. Modern Equipment for Waste Management on Cruise Ships, 8th INTERNATIONAL CONFERENCE ON MARINE TECHNOLOGY-in memoriam academician Zlatko Winkler, 2019, Rijeka, Hrvatska

#### POZVANA PREDAVANJA | INVITED LECTURES

- Hadjina, M.; Bolf, D. Iskustva Sveučilišta RITEH-Ship Design and Construction using 3D Experience, Konferencija obrazovanje 4.0 škola po mjeri industrije. 10.-11.11., 2019, FSB Zagreb, Hrvatska

#### MEĐUNARODNA SURADNJA | INTERNATIONAL COLLABORATIONS

- AALTO University School of Engineering, Helsinki, Finska, Finland
- Norwegian University of Science and Technology, Center of Ships and Ocean Structures, Norwegian Center of Excellence, Trondheim, Norveška, Norway
- Technical University of Lisbon, Instituto Superior Tecnico, Lisabon, Portugal, Portugal
- University of Trieste, Department of Naval Architecture and Ocean Engineering, Trieste, Italija Italy
- University of Washington, Department of Industrial and Systems Engineering, Seattle, SAD, USA
- University of Naples, Naples, Italija, Italy
- Columbia University, Department of Mechanical Engineering, New York City, SAD, USA
- University of Kobe, Japan, Japan
- University of Ljubljana, Faculty of Maritime Studies and Transport, Portorož, Slovenija, Slovenia
- Chalmers University of Technology, Švedska, Sweden



**5<sup>3</sup>**

**zavod za elektroenergetiku**  
**department of electric power systems**





## djelatnici faculty and staff

### PREDSTOJNIK ZAVODA | DEPARTMENT HEAD:



Izv. prof. dr. sc. / Assoc. Prof. D. Sc. **Dubravko Franković**  
vođenje elektroenergetskog sustava; elektrane; projektiranje električnih postrojenja; obnovljivi izvori energije  
electric power systems control; power plants; power installations design; renewable energy sources

### REDOVITI PROFESOR | PROFESSOR



**Alfredo Višković**  
elektroenergetski sustavi; tržište električne energije; razvoj energetske projekata  
electric power systems; electricity markets; power generation project development

### IZVANREDNI PROFESOR | ASSOCIATE PROFESSOR



**Saša Sladić**  
energetska elektronika; elektromotorni pogoni; mehatronika; nove tehnologije i obnovljivi izvori energije  
power electronic; electric drives; mechatronics  
new technologies and renewable energy sources

### DOCENTI | ASSISTANT PROFESSORS



**Vedran Kirinčić**  
nadzor, zaštita i vođenje elektroenergetskog sustava; napredne mreže; električna postrojenja  
power system monitoring; protection and control; smart grids; electric facilities



**Rene Prenc**  
elektroenergetski sustavi; projektiranje; distribuirani izvori  
electric power systems; electrical design; distributed generation

### VIŠI PREDAVAČI | SENIOR LECTURERS

#### Branka Dobraš

nadzor i vođenje elektroenergetskog sustava; modeliranje procesnih informacija; objektno orijentirano modeliranje  
electric power system control; process information modelling; object oriented modeling



#### Marijana Živić-Đurović

kvaliteta električne energije; pouzdanost; mikromreže  
quality of electricity supply; reliability; microgrids



### POSLIJEDOKTORAND | POSTDOCTORAL RESEARCH ASSISTANT

#### Vladimir Franki

elektroenergetski sustavi; tržište električne energije; razvoj energetske projekata  
electric power systems; electrical engineering fundamentals



### ASISTENTI | ASSISTANTS

#### Alen Jakoplić

elektroenergetski sustavi; projektiranje; elektrane  
electric power systems; power plants; electrical design; renewable energy sources; photovoltaic systems



#### Michelle Rojnić

elektroenergetski sustavi; električni strojevi  
electric power systems; electrical machines



#### Ingrid Sterpin

elektroenergetski sustav; vođenje sustava; napredne mreže  
electric power system; power system control; smart-grid



## VANJSKI SURADNICI | ASSOCIATES

Dino Mađar HOPS | HEP TSO  
Vitimir Komen HEP ODS | HEP DSO  
Vladimir Valentić HEP OPS | HEP TSO

Goran Klobučar  
Ranko Lončarić  
Igor Majkić Tehnička škola Rijeka

## nastava i znanost education and science

Nastava se izvodi iz područja osnova elektrotehnike, elektroenergetike i elektrostrojarstva.

CO: Elektroenergetika

Lectures in the field of electrical engineering fundamentals, power engineering and electrical machines and drives.

LLL: Power Systems

## KOLEGIJI NA PREDDIPLOMSKIM SVEUČILIŠNIM STUDIJIMA

| UNDERGRADUATE UNIVERSITY COURSES

- Električna postrojenja
- Električni strojevi
- Elektroenergetske mreže
- Elektromotorni pogoni
- Elektrotehnika R
- Energetska elektronika
- Modeliranje procesnih informacijskih sustava
- Osnove elektrotehnike I
- Osnove elektrotehnike II
- Electric Facilities
- Electrical Machines
- Electric Power Networks
- Electrical Drives
- Electrical Engineering R
- Power Electronics
- Modeling of Process Informatics in Power System
- Fundamentals of Electrical Engineering I
- Fundamentals of Electrical Engineering II

## KOLEGIJI NA PREDDIPLOMSKIM STRUČNIM STUDIJIMA

| UNDERGRADUATE VOCATIONAL COURSES

- Električne energetske mreže
- Elektroenergetska postrojenja
- Elementi elektroenergetskih postrojenja
- Izgradnja i održavanje elektroenergetskih postrojenja
- Osnove električnih strojeva
- Osnove elektrotehnike
- Osnove elektrotehnike ST I
- Osnove elektrotehnike ST II
- Osnove energetske elektronike
- Osnove projektiranja elektroenergetskih postrojenja
- Stručna praksa I
- Stručna praksa II
- Zaštita električnih postrojenja
- Electrical Power Networks
- Electric Power Plants
- Electrical Power Facilities Equipment
- Construction and Maintenance of Power Plants
- Fundamentals of Electrical Machines
- Fundamentals of Electrical Engineering
- Fundamentals of Electrical Engineering ST I
- Fundamentals of Electrical Engineering ST II
- Fundamentals of Power Electronics
- Fundamentals of Electric Power Facilities Design
- Professional practice I
- Professional practice II
- Power System Protection

## KOLEGIJI NA DIPLOMSKIM SVEUČILIŠNIM STUDIJIMA

| GRADUATE UNIVERSITY COURSES

- Brodska elektrotehnika
- Elektrane
- Elektroenergetski sustavi
- Modeliranje procesne informatike električnih postrojenja
- Numerička analiza u elektromagnetizmu
- Ships Electrical Engineering
- Power Plants
- Electric Power Systems
- Modeling of Process Informatics in Power System
- Numerical Analysis in Electromagnetism

- Prijenos i distribucija električne energije
- Projektiranje električnih postrojenja
- Elektromagnetizam
- Vođenje elektroenergetskog sustava
- Zaštita i automatika električnih postrojenja
- Urbani energetske sustavi
- Tehnika visokog napona
- Tržište električne energije
- Transmission and Distribution of Electrical Energy
- Electric Power Substation Design
- Electromagnetics
- Power System Control
- Protection and Automation of Electrical Installations
- Urban Energy Systems
- High Voltage Engineering
- Electricity Market

## KOLEGIJI NA POSLIJEDIPLOMSKIM (DOKTORSKIM) SVEUČILIŠNIM STUDIJIMA

| POSTGRADUATE UNIVERSITY (DOCTORAL) COURSES

- Modeli stohastičkih procesa informacija
- Modeliranje sustava za distribuciju i potrošnju električne energije
- Aktivne distribucijske mreže
- Inteligentni elektroenergetski sustavi – Smart Grids
- Izabrana poglavlja iz energetske komponente i sustava obnovljivih izvora energije
- Nova energetska paradigma
- Models of Stochastic Information Processes
- Modeling of Electrical Power Distribution Systems
- Active Distribution Networks
- Intelligent Power Systems - Smart Grids
- Selected Chapters on Energy Components and Systems of Renewable Energy Sources
- New Energy Paradigm

## ZNANSTVENOISTRAŽIVAČKI RAD | SCIENTIFIC RESEARCH

- Automatsko vođenje elektroenergetskog sustava; Napredne mreže; Mikromreže; Modeliranje elektroenergetskog sustava u stvarnom vremenu; Nadzor, zaštita i upravljanje elektroenergetskog sustava u stvarnom vremenu; Sinkronizirana mjerenja System Integrity protection Scheme; Smart Transmission Grid; Microgrids; Power System Modelling in Real Time; Wide Area Monitoring, Protection and Control of the Power System in Real Time; Synchronized Measurement
- Estimacija stanja elektroenergetskog sustava; Nadzor, zaštita i upravljanje elektroenergetskog sustava u realnom vremenu; Tehnologija sinkroniziranih mjerenja fazora Power System State Estimation; Wide Area Monitoring, Protection and Control of the Power System in Real Time; Synchronized Measurement Technology
- Razvoj suvremenih učinkovitih DC/DC i DC/AC pretvarača Design of modern power DC/DC and DC/AC converters
- Obnovljivi izvori energije, Fotonaponski sustavi, Napredne mreže Renewable energy systems, Photovoltaic systems, Smart grid

## PROJEKTI | PROJECTS

- Elektrifikacija željezničkih vagona za prijevoz kontejnera-hladnjača (REEWA) Railway wagon electrification for reefer containers transport (REEWA)

## PUBLIKACIJE | PUBLICATIONS

## RADOVI U ČASOPISIMA | JOURNAL PAPERS

- Cuculić, A.; Vučetić, D.; Prenc, R.; Čelić, J. Analysis of Energy Storage Implementation on Dynamically Positioned Vessels, *Energies*, 1996-1073, 12, 2019, Basel, Switzerland
- Kirincic, V.; Ceperic, E.; Vlahinic, S.; Lerga, J. Support Vector Machine State Estimation Applied Artificial Intelligence, *0883-9514*, 33, 517-530, 2019, inozemstvo

- Franki, V.; Višković, A.; Šapić, A. *Carbon capture and storage retrofit: Case study for Croatia Energy Sources, Part A: Recovery, Utilization and Environmental Effects*, Print ISSN: 1556-7036 Online ISSN: 1556-7230, 41, 01-13, 2019
- Kirinčić, V.; Lerga, J.; Saulig, N.; Franković, D. *Improved Power System State Estimator with Preprocessing Based on the Modified Intersection of Confidence Intervals*, *Sustainable energy, grids and networks*, 2352-4677, 21, 2020, inozemstvo
- Vlahinić, S.; Franković, D.; Komen, V.; Antonić, A. *Reactive Power Compensation with PV Inverters for System Loss Reduction*, *Energies*, 12, 2019, inozemstvo

#### MEĐUNARODNI KONGRESI | INTERNATIONAL CONGRESSES

- Franković, D.; Bulić, N.; Jakoplić, A.; Rosanda, B.; Reefer container power supply and supervision system onboard railway wagons, *V international scientific congress Innovations*, 66-69, 2019, Varna, Bulgaria
- Kirincic, V.; Radulovic, D.; Dragovic Matosovic, M.; Lalic, G. *Insights from the Sustainable Energy Action Plan revision - is the 2030 goal achievable?*, *Conference on Sustainable Development of Energy, Water and Environment Systems SDEWES*, 1847-7178, 1-6, 2019, Dubrovnik, Hrvatska
- Jakoplic, A.; Frankovic, D.; Kirincic, V.; Plavsic, T. *Usage of Cloud Tracking Solar Forecasting Methodology in Power System Operation*, *Conference on Sustainable Development of Energy, Water and Environment Systems SDEWES*, 1847-7178, 1-18, 2019, Dubrovnik, Hrvatska
- Višković, A.; Šimunić, D.; Franki, V. *Innovation Platfirm – A Novel Energy Service Utility MIPRO 2020*, 2020, Opatija, Hrvatska
- Frankovic, D.; Jakoplic, A.; Rosanda, B.; Rojnic, M. *Environmental benefits of reefer container power supply onboard railway wagons*, *ICACER 2020*, 2020, Barcelona, Španjolska

#### MEĐUNARODNA SURADNJA | INTERNATIONAL COLLABORATIONS

- KIOS Research Center for Intelligent Systems and Networks, *Cipar, Cyprus*
- University of Cyprus, *Electrical and Computer Engineering Department, Cipar, Cyprus*
- The University of Manchester, *The School of Electrical and Electronic Engineering, Velika Britanija, United Kingdom*

54

**zavod za industrijsko inženjerstvo i  
management**  
department of industrial engineering  
and management



172





## djelatnici faculty and staff

### PREDSTOJNIK ZAVODA | DEPARTMENT HEAD:



Prof. dr. sc. / Prof. D. Sc. **Zoran Jurković**

*alatni strojevi i oprema; CAD/CAM/CAE; dizajn alata i naprava; modeliranje, simulacija i optimizacija procesa obrade; planiranje eksperimenta*

*machine tools & equipment; CAD/CAM/CAE; design of tools and fixtures; modeling, simulation and optimization of machining processes; design of experiments*

### REDOVITI PROFESORI U TRAJNOM ZVANJU | TENURED PROFESSORS



**Goran Cukor**

*napredni obradni sustavi i tehnologije; modeliranje i optimiranje obradnih procesa*

*advanced manufacturing systems and technology; modelling and optimisation of machining processes*



**Tonči Mikac**

*proizvodno strojarstvo; projektiranje proizvodnih sustava; CIM; planiranje i upravljanje proizvodnjom; proizvodni management; projektni management; organizacija i ekonomika poslovnih sustava*

*production engineering; designing of manufacturing systems; CIM; production planning and control; production management; project management; organization of manufacturing and business systems*



**Duško Pavletić**

*upravljanje kvalitetom; osiguranje i nadzor kvalitete; sustavi kvalitete; zavarivačko inženjerstvo; spajanje materijala; mjeriteljstvo; mjerenje i kontrola kvalitete*

*quality management; quality assurance and control; quality systems; welding engineering; joining of materials; metrology; measurements and quality control*



**Mladen Perinić**

*projektiranje tehnoloških procesa; CAM, CAP, CAD/NC-CIM; modeliranje, simulacija i optimizacija tehnoloških procesa*

*process planning; CAM, CAP, CAD/NC-CIM; modeling, simulation and processes plans optimization*

**Milan Ikonić**



*proizvodno strojarstvo; projektiranje proizvodnih sustava; CIM; planiranje i upravljanje proizvodnjom; proizvodni management; projektni management; organizacija i ekonomika poslovnih sustava*

*production engineering; designing of manufacturing systems; CIM; production planning and control; production management; project management; organization of manufacturing and business systems*

### DOCENTI | ASSISTANT PROFESSORS

**Sandro Doboviček**



*organizacija proizvodnje; proizvodni management; projektiranje proizvodnih sustava*

*operations and process management; manufacturing system design*

**Samir Žic**



*planiranje i upravljanje proizvodnjom; organizacija i ekonomika poslovnih sustava; management i organizacijski razvoj*

*production planning and control; organization and economics of business systems; management and organizational development*

### ASISTENTI | ASSISTANTS

**David Ištoković**



*projektiranje tehnoloških procesa; CAM, CAP, CAD/NC-CIM; modeliranje, simulacija i optimizacija tehnoloških procesa*

*process planning; CAM, CAP, CAD/NC-CIM; modeling, simulation and processes plans optimization*

**Maja Marković**



*upravljanje kvalitetom; osiguranje i nadzor kvalitete; mjerenje i kontrola kvalitete*

*quality management; quality assurance and control; measurements and quality control*

**Graciela Šterpin Valić**



*napredni proizvodni sustavi i tehnologije; alatni strojevi i oprema; modeliranje i optimiranje obradnih procesa*

*advanced manufacturing systems and technology; machine tools and equipment; modeling and optimization of machining processes*



## PROFESOR EMERITUS | PROFESSOR EMERITUS



Elso Kuljanić

Akademik HAZU

HAZU academician

## VANJSKI SURADNICI | ASSOCIATES

## Marko Fabić

Klinički bolnički centar Rijeka  
| Clinical Hospital Center Rijekaodržavanje  
maintenance

## Toni Vidolin

3. MAJ Brodogradilište d.d., Rijeka  
| 3. MAJ Shipyard JSC, Rijekatehnologija zavarivanja  
welding technology

## Valter Uran

TEH-CUT d.o.o.

organizacija proizvodnje  
operations management

## nastava i znanost education and science

Nastava iz područja: mjerne tehnike i sustava kvalitete, organizacije i operacijskog menadžment, proizvodne tehnologije, proizvodne opreme i robotike, projektiranja procesa

Lectures in the field of: measuring technique and quality systems, organization and operational management, manufacturing technologies, manufacturing equipments and robotics, process planning

## KOLEGIJI NA PREDDIPLOMSKIM SVEUČILIŠNIM STUDIJIMA

| UNDERGRADUATE UNIVERSITY COURSES

- Proizvodne tehnologije
- Mjerenja i kontrola kvalitete
- Osiguranje kvalitete
- Zavarivanje I
- Proizvodni strojevi, alati i naprave
- Organizacija i ekonomika poslovnih sustava
- Planiranje i upravljanje proizvodnjom
- Tehnološki procesi
- Manufacturing Technologies
- Measurements and Quality Control
- Quality Assurance
- Zavarivanje I
- Production Machines, Tools, Jigs and Fixtures
- Organization and Economics of Business Entity
- Production Planning and Management
- Technological Processes

## KOLEGIJI NA DIPLOMSKIM SVEUČILIŠNIM STUDIJIMA

| GRADUATE UNIVERSITY COURSES

- Napredni proizvodni postupci
- Obrada odvajanjem čestica
- Tehnologija oblikovanja
- Mjerenje u proizvodnji
- Upravljanje kvalitetom
- Fleksibilni i inteligentni sustavi
- Industrijska robotika
- Zavarivanje II
- Spajanje materijala
- CNC/NC obradni strojevi
- Organizacija proizvodnje
- Projektiranje proizvodnih sustava
- Računalom integrirana proizvodnja
- Proizvodni management
- Advanced Manufacturing Processes
- Metal Cutting Processes
- Metal Forming Technology
- Measurement in industry
- Quality Management
- Flexible and intelligent systems
- Industrial robotics
- Welding Engineering II
- Joining of materials
- CNC/NC Machine Tools
- Operations management
- Manufacturing System Design
- Computer Integrated Manufacturing
- Production Management

- Tehnička logistika
- Management i organizacijski razvoj
- Projektni management
- CAD/CAPP/CAM
- Projektiranje tehnoloških procesa
- Računalna simulacija proizvodnih procesa
- Održavanje

- Technical Logistics
- Management and Organizational Development
- Project Management
- CAD/CAPP/CAM
- Process Planning
- Computer Simulation of Production Processes
- Maintenance

## KOLEGIJI NA PREDDIPLOMSKIM STRUČNIM STUDIJIMA

| UNDERGRADUATE VOCATIONAL COURSES

- Tehnologija obrade I
- Tehnologija obrade II
- Mjerna tehnika ST
- Osiguranje kvalitete ST
- Zavarivanje
- Alati i naprave
- Obradni strojevi
- Organizacija i upravljanje proizvodnjom
- Proizvodni sustavi
- Organizacija i ekonomika
- Tehnološki procesi ST
- Manufacturing Technology I
- Manufacturing Technology II
- Measuring Technique ST
- Quality Assurance ST
- Welding Engineering
- Tools, Jigs and Fixtures
- Machine Tools
- Production Organization and Management
- Production systems
- Organization and Economics
- Technological Processes ST

## KOLEGIJI NA POSLIJEDIPLOMSKIM (DOKTORSKIM) SVEUČILIŠNIM STUDIJIMA

| POSTGRADUATE UNIVERSITY (DOCTORAL) COURSES

- Deformabilnost i suvremeno oblikovanje deformiranjem
- Izabrana poglavlja iz nekonvencionalnih postupaka obrade
- Izabrana poglavlja iz konvencionalne obrade odvajanjem čestica
- Potpuno upravljanje kvalitetom
- Inženjerstvo kvalitete
- Metode simulacije u proizvodnji
- Planiranje i vođenje proizvodnje
- IP iz fleksibilnih proizvodnih sustava
- Razvojni i proizvodni management
- CAM, CAP, CAD/NC-CIM
- Optimizacija tehnoloških procesa
- Formability and Modern Forming Technology
- Selected Chapters on Nonconventional Manufacturing Processes
- Selected Chapters on Conventional Metal Cutting Processes
- Total Quality Management
- Quality Engineering
- Simulation Methods in Production
- Planning and Processing of Manufacture
- Selected Chapters from flexible production system
- Development and Operational Management
- CAM, CAP, CAD/NC-CIM
- Processes Plans Optimization

## ZNANSTVENOISTRAŽIVAČKI RAD | SCIENTIFIC RESEARCH

- Napredni obradni sustavi i tehnologije, tehnologija oblikovanja deformiranjem, modeliranje i optimiranje obradnih procesa, računalna simulacija proizvodnih procesa  
Advanced manufacturing systems and technology, forming technology, modelling and optimisation of machining processes, computational simulation of production processes
- Modeliranje, simulacija i optimizacija procesa obrade. Primjena umjetne inteligencije u upravljanju procesima obrade.  
Modeling, simulation and optimization of manufacturing processes. Application of artificial intelligence in control of manufacturing processes.
- Industrijsko inženjerstvo, upravljanje i osiguranje kvalitete, mjerenja i kontrola kvalitete, mjerenja u proizvodnji, spajanje materijala, zavarivanje  
Industrial engineering, quality management, quality assurance, measurements and quality control, industrial measurements, joining of materials, welding

- *Proizvodno strojarstvo; proizvodni sustavi; CIM, planiranje i upravljanje proizvodnjom, proizvodni management, organizacija poslovnih sustava*  
*Production engineering, manufacturing systems, CIM, production planning and control, production management, organization of manufacturing and business systems*

**PROJEKTI | PROJECTS**

- *Primjena tehnologija inkrementalnog oblikovanja u individualnoj proizvodnji izradaka iz naprednih polimernih materijala, uniri-tehnic-18-100-1235, istraživačka potpora Sveučilišta u Rijeci, Zoran Jurković, 2018.-2021., znanstvenoistraživački projekt.*  
*Application of incremental forming technologies in individual production of parts from advanced polymer materials, uniri-tehnic-18-100-1235, University of Rijeka, Zoran Jurkovic, 2018.-2021., research and scientific project.*
- *Razvoj metodologije projektiranja i postupka umjeravanja rekonfigurabilnog mjernog sustava, Sveučilište u Rijeci, Duško Pavletić, 2018.-2021., znanstvenoistraživački projekt.*  
*Design principles and calibration method of reconfigurable inspection system, University of Rijeka, Duško Pavletić, 2018.-2021., research and scientific project.*
- *Istraživanje alternativnih tehnika hlađenja-podmazivanja za održivu strojnu obradu teško obradivih materijala, uniri-tehnic-18-293, istraživačka potpora Sveučilišta u Rijeci, Goran Cukor, 2018.-2021., znanstvenoistraživački projekt*  
*Investigation of alternative cooling-lubrication techniques for sustainable machining of difficult-to-cut materials, uniri-tehnic-18-293, University of Rijeka, Goran Cukor, 2018-2021, research and scientific project*
- *Napredne metode simulacije operativne pripreme planiranja proizvodnje, istraživačka potpora Sveučilišta u Rijeci, Mladen Perinić, 2018.-2021., znanstvenoistraživački projekt.*  
*Advanced methods of simulating the operational preparation of production planning, University of Rijeka, Mladen Perinić, 2018.-2021., research and scientific project.*

**PUBLIKACIJE | PUBLICATIONS****RADOVI U ČASOPISIMA | JOURNAL PAPERS**

- *Sterpin Valić, G.; Cukor, G.; Jurkovic, Z.; Brezocnik, M. Multi-Criteria Optimization of Turning of Martensitic Stainless Steel for Sustainability, International Journal of Simulation Modelling, ISSN 1726-4529, Vol. 18, No. 4, 632-642, 2019., Austrija*
- *Fabić, M.; Pavletić D.; Šterpin-Valić, G.; Marković, M. Moderating impact of complexity on process management of turnaround project, Management and Production Engineering Review, ISSN 2080-8208, Vol. 10, No. 4 25-36, 2019., Poljska*
- *Randić, M.; Pavletić, D.; Turkalj, G. Multiparametric Investigation of Welding Techniques on Toe Radius of High Strength Steel at Low-Temperature Levels Using 3D-Scanning Techniques Metals, ISSN 2075-4701, Vol. 9, No. 12, 1355, 2019., Switzerland*
- *Cukor, G.; Šterpin-Valić, G.; Kostadin, T.; Fabić, M. Sustainable Turning of Martensitic Stainless Steel Transactions of FAMENA, ISSN 1333-1124, Vol. 43, No. 3, 1-12, 2019., Zagreb*

**MEĐUNARODNI KONGRESI | INTERNATIONAL CONGRESSES**

- *Ištoković, D.; Perinić, M.; Jurković, Z. Minimizing the makespan in the flowshop with sequence-dependent setup times: simulation approach, 9th, International Conference Mechanical Technology and Structural Materials - MTSM 2019, ISSN 1847-7917, 77-82, 2019., Split*
- *Marković, M.; Doboviček, S.; Pavletić, D.; Runje, B. Concept of reconfigurable inspection system, 9th International Conference Mechanical Technology and Structural Materials - MTSM 2019 ISSN 1847-7917, 121-126, 2019., Split*

**MEĐUNARODNA SURADNJA | INTERNATIONAL COLLABORATIONS**

- *Università degli Studi di Udine, Facoltà di Ingegneria, Dipartimento di Ingegneria Elettrica, Gestionale e Meccanica (DIEGM), Italia, Italija, Italy*
- *University of Maribor, Faculty of Mechanical Engineering, Production Engineering Institute Slovenija, Slovenia*
- *University of Kragujevac, Faculty of Engineering, Department for Production Engineering, Srbija, Serbia*
- *University of Novi Sad, Faculty of Technical Sciences, Department of Production Engineering, Srbija, Serbia*
- *University of Montenegro, Faculty of Mechanical Engineering, Podgorica, Crna Gora, Montenegro*
- *University of Banja Luka, Faculty of Mechanical Engineering, Bosna i Hercegovina, Bosnia & Herzegovina*
- *Ss. Cyril and Methodius University in Skopje, Faculty of Mechanical Engineering, Institute of Production Engineering and Management, Republika Makedonija, Republic of Macedonia*
- *Faculty of Mechanical Engineering, University of Zilina, Slovačka, Slovakia*
- *Poznan Politechnic, Technical University of Poznan, Poljska, Poland*
- *University of Ljubljana, Faculty of Mechanical Engineering, Slovenija, Slovenia*



**5.**

**zavod za konstruiranje u strojarstvu**  
**department of mechanical**  
**engineering design**





## djelatnici faculty and staff

### PREDSTOJNICA ZAVODA | DEPARTMENT HEAD:



Doc. dr. sc. / Assist. Prof. D. Sc. **Kristina Marković**

*inženjerska grafika; dokumentiranje; tehničko crtanje; oblikovanje pomoću računala; tehničko dokumentiranje; precizno inženjerstvo; konstrukcijski elementi robota*  
*engineering graphics; documenting; technical drawing; modelling by computer; technical documenting; precision engineering; robot elements design*

### REDOVITI PROFESORI U TRAJNOM ZVANJU | TENURED PROFESSORS



**Neven Lovrin**

*konstrukcijski elementi; mehanički prijenosnici snage; transportna sredstva u industriji; brodski palubni strojevi; tehnička logistika; inženjerska etika*  
*machine elements; mechanical power transmissions; industrial transport equipment and devices; ship's deck machinery; technical logistics; engineering ethics*



**Saša Zelenika**

*precizno inženjerstvo; tehnologija mikrosustava; MEMS i NEMS; sustavi žetve energije; mjerni sustavi; konstrukcijski elementi; mehatronika*  
*precision engineering; microsystems technologies; MEMS and NEMS; energy harvesting devices; measurement systems; machine elements; mechatronics*

### REDOVITI PROFESORI | PROFESSORS



**Robert Basan**

*ponašanje i zamor materijala; odabir materijala; konstruiranje i oblikovanje proizvoda; metodičko konstruiranje; računalom podržano inženjerstvo (CAE)*  
*behaviour and fatigue of materials; material selection; product design in mechanical engineering; systematic engineering design; computer aided engineering (CAE)*



**Marina Franulović**

*konstrukcijski elementi; mehaničke konstrukcije; modeliranje oštećenja i analiza nosivosti elemenata i sklopova*  
*machine elements; mechanical design of machine components; damage modelling and load carrying capacity analysis of elements and components*

### DOCENTI | ASSISTANT PROFESSORS

**Goran Gregov**

*prijenosnici snage; hidraulika i pneumatika; mehatronika*  
*power transmissions; hydraulics and pneumatics; mechatronics*



**Ervin Kamenar**

*precizno inženjerstvo; tehnologija mikrosustava; mehatronika; sustavi regulacije i upravljanja; sustavi žetve energije; mjerni sustavi; meki roboti*  
*precision engineering; microsystems technologies; mechatronics; control systems; energy scavenging devices; measurement systems; soft robotics*

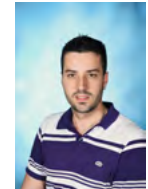

**Tea Marohnić**

*ponašanje i zamor materijala; inženjerska grafika; tehničko crtanje; oblikovanje pomoću računala; CAE; metodičko konstruiranje; konstruiranje i oblikovanje proizvoda*  
*behaviour and fatigue of materials; engineering graphics; technical drawing; modelling by computer; CAE; systematic product design; design in mechanical engineering*



**Sanjin Troha**

*inženjerska grafika; dokumentiranje; tehničko crtanje; oblikovanje pomoću računala; konstrukcijski elementi*  
*engineering graphics; documenting; technical drawing; modelling by computer; machine elements*



**Željko Vrcan**

*konstrukcijski elementi; mehanički prijenosnici snage; transportna sredstva u industriji; mjerenje buke*  
*machine elements; mechanical power transmissions; industrial transport equipment and devices; noise measurement*



### POS LIJEDOKTORAND | POSTDOCTORAL RESEARCH ASSISTANT

**Marko Perčić**

*inženjerska grafika; dokumentiranje; tehničko crtanje; oblikovanje pomoću računala; tehničko dokumentiranje; tehnologija nanosustava; tribologija*  
*engineering graphics; documenting; technical drawing; modelling by computer; technical documenting; nanosystems technology; tribology*



## ASISTENTI | ASSISTANTS

**Tomislav Bazina**

*precizno inženjerstvo; konstrukcijski elementi; mjerni sustavi; mehatronika*

*precision engineering; machine elements; measurement systems; mechatronics*

**Maja Dundović**

*inženjerska grafika; tehničko crtanje; oblikovanje pomoću računala; konstrukcijski elementi; konstrukcijski elementi robota*

*engineering graphics; technical drawing; modelling by computer; machine elements; robot elements design*

**Matej Gljuščić**

*konstrukcijski elementi; elementi strojeva; mehaničke konstrukcije; napredni materijali; modeliranje ponašanja materijala*

*machine elements design; machine elements; mechanical design of machine components; advanced materials; modeling of material behaviour*

**Petar Gljuščić**

*precizno inženjerstvo; sustavi žetve energije; konstrukcijski elementi; mjerni sustavi*

*precision engineering; energy harvesting devices; machine elements; measurement systems*

**David Liović**

*konstrukcijski elementi; mehaničke konstrukcije; napredni materijali; modeliranje ponašanja materijala*

*machine elements design; mechanical design of machine components; advanced materials; modeling of material behaviour*

## PROFESOR EMERITUS | PROFESSOR EMERITUS

**Božidar Križan**

*konstrukcijski elementi; konstruiranje i oblikovanje proizvoda*  
*machine elements; systematic product design*

**nastava i znanost**  
**education and science**

*Nastava se izvodi iz područja: konstruiranje u strojarstvu, numeričke metode u konstruiranju, konstrukcijski elementi, mehanički prijenosnici snage, hidrostatski i pneumatski sustavi prijenosa snage i upravljanja, zupčani prijenosnici, tribologija, transportna sredstva u industriji, brodski palubni strojevi, tehnička logistika, mehatronika, precizno inženjerstvo, tehnologija mikrosustava, MEMS i NEMS, mjerni sustavi, inženjerska grafika i dokumentiranje, oblikovanje pomoću računala, inženjerska vizualizacija, metoda rubnih elemenata.*

*CO: Oblikovanje 3D modela, Oblikovanje pomoću računala CO*

*Lectures in the field of: design in mechanical engineering, numerical methods in design, machine elements, mechanical power transmissions, fluid power systems and control, gear transmissions, tribology, industrial transport equipment and devices, ship's deck machinery, technical logistics, mechatronics, precision engineering, microsystems technologies, MEMS and NEMS, measurement systems, engineering graphics and documenting, modelling by computer, engineering visualization, boundary element method.*

*LLL: 3D modelling, Modelling by Computer CO*

**KOLEGIJI NA PREDDIPLOMSKIM SVEUČILIŠNIM STUDIJIMA**

| UNDERGRADUATE UNIVERSITY COURSES

- Inženjerska grafika
- Inženjerska grafika i dokumentiranje
- Izborni projekt - Konstrukcijski elementi I
- Izborni projekt - Konstrukcijski elementi II
- Izborni projekt - Konstruiranje i oblikovanje
- Konstruiranje i oblikovanje
- Konstrukcijski elementi I
- Konstrukcijski elementi II
- Oblikovanje pomoću računala
- Osnove konstruiranja
- Osnove konstrukcijskih elemenata
- Engineering Graphics
- Engineering Graphics and Documenting
- Elective project - Machine Elements Design I
- Elective project - Machine Elements Design II
- Elective Project - Designing and Product Shaping
- Designing and Product Shaping
- Machine Elements Design I
- Machine Elements Design II
- Modelling by Computer
- Fundamentals of Mechanical Engineering Design
- Fundamentals of Machine Elements Design

**KOLEGIJI NA DIPLOMSKIM SVEUČILIŠNIM STUDIJIMA**

| GRADUATE UNIVERSITY COURSES

- Brodski palubni strojevi
- CAE u razvoju proizvoda
- Elementi transportne tehnike
- Inženjerska vizualizacija
- Komponente mehatroničkih sustava
- Konstrukcijski elementi robota
- Laboratorijske vježbe A
- Laboratorijske vježbe B
- Mehaničke konstrukcije
- Metodičko konstruiranje
- Mikro- i nanoelektromehanički sustavi
- Modeliranje hidrauličkih i pneumatskih sustava
- Numeričke metode u konstruiranju
- Ship's Deck Machinery
- CAE in Product Development
- Elements of the Transport Technic
- Engineering Visualization
- Components of mechatronic systems
- Robot Elements Design
- Laboratory exercises A
- Laboratory exercises B
- Mechanical Design of Machine Components
- Systematic Engineering Design
- Micro- and Nanoelectromechanical Systems
- Modelling of hydraulics and pneumatics systems
- Numerical Methods in Mechanical Engineering Design

- *Precizne konstrukcije i tehnologija mikrosustava*
- *Prijenosnici snage*
- *Projekt I - Inženjerska vizualizacija*
- *Projekt I - Mehaničke konstrukcije*
- *Projekt I - Konstrukcijski elementi robota*
- *Projekt I - Prijenosnici snage*
- *Projekt I - Metodičko konstruiranje*
- *Projekt II - CAE u razvoju proizvoda*
- *Projekt II – Elementi transportne tehnike*
- *Projekt II - Modeliranje hidrauličkih i pneumatskih sustava*
- *Projekt II - Precizne konstrukcije i tehnologija mikrosustava*
- *Tehnička logistika*
- *Transportni sustavi*
- *Upravljanje mehatroničkim sustavima*
- *Mehaničko ponašanje i odabir materijala*
- *Precision Engineering and Microsystems Technologies*
- *Power Transmissions*
- *Project I - Engineering Visualization*
- *Project I - Mechanical Design of Machine Components*
- *Project I - Robot Elements Design*
- *Project I - Mechanical Power Transmissions*
- *Project I - Systematic Engineering Design*
- *Project II - CAE in Product Development*
- *Project II – Elements of the Transport Technic*
- *Project II - Modelling of hydraulics and pneumatics*
- *Project II - Precision Engineering and Microsystems Technologies*
- *Technical Logistics*
- *Transport Systems*
- *Control of Mechatronics Systems*
- *Mechanical Behaviour and Material Selection*

#### KOLEGIJI NA PREDDIPLOMSKIM STRUČNIM STUDIJIMA

| UNDERGRADUATE VOCATIONAL COURSES

- *Elementi strojeva I*
- *Elementi strojeva I BG*
- *Elementi strojeva II*
- *Hidraulika i pneumatika*
- *Konstruiranje*
- *Osnove mehatronike*
- *Tehničko crtanje*
- *Tehničko dokumentiranje*
- *Machine Elements I*
- *Machine Elements I NA*
- *Machine Elements II*
- *Hydraulics and pneumatics*
- *Mechanical Engineering Design*
- *Fundamentals of Mechatronics*
- *Technical Drawing*
- *Technical Documenting*

#### KOLEGIJI NA POSLIJEDIPLOMSKIM (DOKTORSKIM) SVEUČILIŠNIM STUDIJIMA

| POSTGRADUATE UNIVERSITY (DOCTORAL) COURSES

- *Izabrana poglavlja iz hidrostatskih i pneumatskih prijenosa*
- *Izabrana poglavlja iz konstrukcijskih elemenata*
- *Izabrana poglavlja iz prijenosnika snage*
- *Izabrana poglavlja iz transportnih sredstava u industriji*
- *Kontaktne probleme u analizi konstrukcijskih elemenata*
- *Modeliranje inženjerskih konstrukcija*
- *Nauka o konstruiranju*
- *Podatljivi elementi i mehanizmi*
- *Principi konstrukcija visokih i ultravisokih preciznosti*
- *Specijalni mehanički prijenosnici*
- *Selected Chapters on Hydrostatic and Pneumatic Transmissions*
- *Selected Chapters on Machine Elements*
- *Selected Chapters on Power Transmission*
- *Selected Chapters on Industrial Transport Equipment and Devices*
- *Contact Problems in Machine Elements Analyses*
- *Modelling of Engineering Structures*
- *Design Science*
- *Compliant Elements and Mechanisms*
- *Principles of High and Ultra-High Precision Devices*
- *Special Mechanical Transmissions*

#### ZNANSTVENOISTRAŽIVAČKI RAD | SCIENTIFIC RESEARCH

- *Hidrostatski pogoni, Pneumatski sustavi*  
*Hydrostatic transmission, Pneumatic systems*
- *Karakterizacija i numeričko modeliranje ponašanja materijala*  
*Characterisation and numerical modelling of material behaviour*

- *Konstrukcijsko strojarstvo*  
*Mechanical engineering design*
- *Kontaktne probleme u konstrukcijskim elementima.*  
*Contact problems in machine elements.*
- *Modeliranje*  
*Modelling*
- *Precizno inženjerstvo: podatljivi mehanizmi, pozicioniranje ultravisokih preciznosti i točnosti, strukturna analiza, integracija u mehatroničke sustave, mjerne tehnike.*  
*Precision engineering: compliant mechanisms, ultra-high precision positioning, structural analysis, integration into mechatronics devices, measurement techniques.*
- *Prijenos energije i informacija u hidrauličkim i pneumatskim sustavima.*  
*The energy and information transmission in hydraulic and pneumatic systems.*
- *Procjena parametara materijala primjenom klasičnih metoda i neuronskih mreža*  
*Estimation of material properties by means of classical methods and neural networks*
- *Tehnologija mikro- i nanosustava: MEMS, manipulacija, montaža i pakiranje, skalirajući učinci, proizvodnja mikrostruktura, prikupljanje niskorazinske energije iz okoliša, tribologija*  
*Micro- and nanosystems technologies: MEMS, handling, assembly and packaging, scaling effects, micro-fabrication, energy harvesting, tribology*
- *Zamor materijala*  
*Fatigue of materials*
- *Zupčasti prijenosnici, planetarni prijenosi, evolventno ozubljenje s velikim stupnjem prekrivanja profila, transportni sustavi, inženjerska etika.*  
*Gear transmissions, planetary gears, high transverse contact ratio gears, transport systems, engineering ethics.*
- *Mehaničko ponašanje materijala*  
*Mechanical behaviour of materials*
- *Mjerenje buke*  
*Noise measurement*
- *Fotoelastična ispitivanja*  
*Photoelastic Measurement*

#### PROJEKTI | PROJECTS

- *Karakterizacija i istraživanje ponašanja naprednih materijala za strojarske komponente, projekt Sveučilišta u Rijeci, voditeljica Marina Franulović, 2018-2021*  
*Characterization and behavior research of advanced materials for mechanical components, Project of University of Rijeka, Marina Franulović, 2018-2021*
- *Inovativne mehatroničke konstrukcije za pametna tehnološka rješenja, znanstveni projekt Sveučilišta u Rijeci, voditelj Saša Zelenika, 2019-2022*  
*Advanced mechatronics devices for smart technological solutions, University of Rijeka scientific project, Saša Zelenika, 2019-2022*
- *Istraživanje i razvoj prediktivnih modela ponašanja konstrukcijskih materijala temeljenih na metodama strojnog učenja, Potpore znanstvenim istraživanjima na Sveučilištu u Rijeci, voditelj Robert Basan, 2018-2021*  
*Research and development of machine learning-based predictive models of design relevant materials, Support for Research at the University of Rijeka, principal investigator Robert Basan, 2018-2021*

- *The role of cultural heritage in socio-economic development and preservation of democratic values – HERItage, H2020 EU projekt, Zamjenik koordinatora projekta i Voditelja upravljačkog i logističkog povjerenstva je Saša Zelenika, 2020.*  
*The role of cultural heritage in socio-economic development and preservation of democratic values – HERItage, H2020 EU project, Project Vice-coordinator and Head of the Project Management and Logistics Board is Saša Zelenika, 2020.*
- *Optimising Design for Inspection (ODIN), EU COST akcija CA18203, voditelj WG 3 i hrvatski član Upravnog odbora je Saša Zelenika, 2019-2023*  
*Optimising Design for Inspection (ODIN), EU COST Action CA18203, WG 3 leader and Croatian MC member is Saša Zelenika, 2019-2023*
- *Tribološka karakterizacija materijala od nanometarske do makrometarske razine, bilateralni projekt znanstveno-tehnološke suradnje Hrvatska-Slovenija, voditelj hrvatskog dijela je Saša Zelenika, 2020-2021.*  
*Tribological material characterisation from the nanometric to the macrometric domain, Croatian-Slovenian bilateral project of scientific and technological cooperation, leader of the Croatian participation is Saša Zelenika, 2020-2021.*
- *InterReg projekt Italija – Slovenija „Nano-region“, voditelj suradničkog tima Sveučilišta u Rijeci je Saša Zelenika, 2019-2022.*  
*Italy-Slovenia InteReg project “Nano-region”, leadership of the University of Rijeka, Croatia associate partnership team is Saša Zelenika, 2019-2022.*
- *Mjerenje vibracija na transformatoru, tehnološki projekt u suradnji s tvrtkom Končar D&ST, voditelj Saša Zelenika, 2019-2020.*  
*Measurement of vibrations on a transformer, technological project in collaboration with the Končar D&ST company, leader Saša Zelenika, 2019-2020.*
- *Modeliranje i simulacija u razvoju naprednih materijala - SIMMAT, Istraživački projekt Hrvatske zaklade za znanost, IP-2019-04-3607, voditeljica Marina Franulović 2019-2023*  
*Modelling and simulation in development of advanced materials - SIMMAT, Research project supported by Croatian Science Foundation IP-2019-04-3607, principal investigator Marina Franulović, 2019-2023*
- *Ponašanje monolitnih podatljivih mehanizama izrađenih aditivnim tehnologijama, UNIRI-plus projekt, voditeljica Kristina Marković 2019-2021*  
*Behavior of monolithic compliant mechanisms developed by additive technologies, UNIRI-plus project, principal investigator Kristina Marković 2019-2021*

## PUBLIKACIJE | PUBLICATIONS

## KNJIGE | BOOKS

- *Zelenika, S.; Kamenar, E.; Korda, M.; Mezić, I., Application of Koopman-Based Control in Ultrahigh-Precision Positioning; in "The Koopman Operator in Systems and Control: Concepts, Methodologies and Applications – Lecture Notes in Control and Information Sciences No. 484 (ur. Mauroy A., Mezić I. i Susuki Y.)", Springer Nature, 978-3-030-35713-9, 2020, Heidelberg, Njemačka*

## RADovi U ČASOPISIMA | JOURNAL PAPERS

- *Gljuščić, P.; Zelenika, S.; Blažević, D.; Kamenar, E. Kinetic Energy Harvesting for Wearable Medical Sensors, Sensors 1424-8220, 19(22), 4922, 2020., inozemstvo*
- *Perčić, M.; Zelenika, S.; Mezić, I.; Peter, R.; Krstulović, N. An experimental methodology for the concurrent characterization of multiple parameters influencing nanoscale friction, Friction, 2223-7690, 8 (3), 577-597, 2020., inozemstvo*

- *Kolympadi Marković, M., Peter, R.; Jelovica Badovinac, I.; Saric, I.; Perčić, M.; Radičić, R.; Marković, D.; Knez, M.; Ambrožić, G. 'Sandwich'-like hybrid ZnO thin films produced by a combination of atomic layer deposition and wet-chemistry using a mercapto silane as single organic precursor, Nanotechnology, 0957-4484, 31 (18), 185603 (12pp), 2020., inozemstvo*
- *Petravić, M.; Jelovica Badovinac, I.; Peter, R.; Omerzu, A.; Salamon, K.; Šarić, I.; Samaržija, A.; Perčić, M.; Kavre Piltaver, I.; Ambrožić, G. Grain size effect on photocatalytic activity of TiO2 thin films grown by atomic layer deposition, Thin Solid Films, 0040-6090, 709, 138215 (18pp), 2020. inozemstvo*
- *Troha, S.; Stefanović-Marinović, J.; Vrcan, Ž.; Milovančević, M. Selection of the Optimal Two-Speed Planetary Gear Train for Fishing Boat Propulsion FME Transactions, 1451-2092 48(2) 397-403, 2020., inozemstvo*
- *Troha, S.; Vrcan, Ž.; Karaivanov, D.; Isametova, M. The Selection of Optimal Reversible Two-Speed Planetary Gear Trains for Machine Tool Gearboxes, Facta Universitatis, Series: Mechanical Engineering, 0354-2025, 18(1), 121-134, 2020., inozemstvo*
- *Bolf, D.; Zamarin, A.; Basan, R. Composite Material Damage Processes, Journal of Maritime and Transportation Sciences, 0554-6397, 3, 307-323, 2020., Hrvatska*

## MEĐUNARODNI KONGRESI | INTERNATIONAL CONGRESSES

- *Troha, S.; Stefanović-Marinović, J.; Rončević, B.; Anđelković, B.; Milovančević, M.; Marković, K. An application of multicriteria optimization in selection of the two-speed two-carrier planetary gear trains, 9th International Scientific Conference, IRMES 2019, 978-86-6335-061-8, 2019, Kragujevac, Srbija*
- *Gljuščić, P.; Zelenika, S. Assessment of performances of optimized piezoelectric energy harvesters for wearables, Proceedings of the 20th EUSPEN International Conference, 978-0-9957751-7-4, 49-52, 2020, virtualano okruženje*
- *Perčić, M.; Zelenika, S.; Mezić, I. A supervised machine learning approach to a predictive model of nanoscale friction, Proceedings of the 20th EUSPEN International Conference, 978-0-9957751-7-5, 69-70, 2020, virtualano okruženje*
- *Bazina, T.; Zelenika, S.; Kamenar, E.; Schnurrer-Luke-Vrbanić, T. Critical validation of design strategies for a compact upper limb mechatronics rehabilitation device, Proceedings of the 20th EUSPEN International Conference, 978-0-9957751-7-6, 71-72, 2020, virtualano okruženje*
- *Stefanović-Marinović, J.; Troha, S.; Milovančević, M.; Vrcan, Ž. Structure and Important Parameters Choice of the Two-Speed Two-Carrier Planetary Gear Trains, The 7th International Conference Transport and Logistics, 173-176, 2019, Niš, Srbija*
- *Liović, D.; Franulović, M.; Kozak, D. Material models and mechanical properties of titanium alloys produced by selective laser melting, 4th International Conference on Structural Integrity and Durability ICSID 2020*
- *Gljuščić, M.; Franulović, M.; Lanc, D.; Božić, Ž. Digital image correlation of additively manufactured CFRTP composite systems in static tensile testing, 4th International Conference on Structural Integrity and Durability ICSID 2020*
- *Dundović, M.; Marković, K.; Franulović, M.; Vrcan, Ž. Digital light processing in photoelastic models production for material behavior modeling, 4th International Conference on Structural Integrity and Durability ICSID 2020*
- *Marković, K.; Franulović, M.; Dundović, M.; Vrcan, Ž. "Characterization of rotating compliant mechanisms design solutions for micropositioning application", 4th European Conference on Materials, Mechatronics and Manufacturing EMMM 2020, 1-2, 2020, Singapur*

- Theochari, G.; Troha, S.; Karaivanov, D.: *Some requirements to the mechanisms of handling machines for dangerous goods and solutions for their satisfaction*, 17th International Scientific Congress, MTM 2020, 12-15, 2020, Varna, Bugarska

**MEDUNARODNA SURADNJA | INTERNATIONAL COLLABORATIONS**

- Elettra, Italija, Italy
- Faculty of Industrial Technology, Technical University - Sofia, Bugarska, Bulgaria
- Faculty of Mechanical Engineering, Technical University - Sofia, Bugarska, Bulgaria
- Fakulteta za strojništvo, Univerza v Ljubljani, Slovenija, Slovenia
- Fakulteta za strojništvo, Univerza v Mariboru, Slovenija, Slovenia
- Mašinski fakultet, Univerzitet u Nišu, Srbija, Serbia
- University of Applied Sciences, Graz, Austrija, Austria
- University of Chemical Technology and Metallurgy, Bugarska, Bulgaria
- University of Udine, Italija, Italy
- Moscow State Industrial University, Rusija, Russia
- Institut für Stahlbau und Werkstoffmechanik, Technische Universität Darmstadt, Njemačka, Germany
- Czech Technical University in Prague, Češka Republika, Czech Republic
- Brno University of Technology, Češka Republika, Czech Republic
- Politecnico di Torino, Italija, Italy
- University of Trieste, Italija, Italy
- Istituto Officina dei Materiali (IOM) of the Italian National Research Council (CNR), Italija, Italy
- Mid Sweden University, Švedska, Sweden
- University of California Santa Barbara, Department of Mechanical Engineering, Kalifornija, SAD CA, USA
- Royal Institute of Technology, Švedska, Sweden

**5<sup>6</sup>**

**zavod za matematiku, fiziku,  
strane jezike i kineziologiju**  
**department of mathematics, physics,  
foreign languages and kinesiology**





## djelatnici faculty and staff

### PREDSTOJNICA ZAVODA | DEPARTMENT HEAD:



Prof. dr. sc. / Prof. D. Sc. **Nelida Črnjarić-Žic**

*numerička matematika; znanstveno računanje; računalne simulacije u tehnici; matematičko modeliranje; analiza podataka; dinamički sustavi*  
*numerical mathematics; scientific computing; computer simulations in engineering; mathematical modelling; data analysis*

### DOCENTI | ASSISTANT PROFESSORS



**Ivan Dražić**

*parcijalne diferencijalne jednačbe; mikropolarni fluidi; numerička analiza; statistička obrada podataka; metodika nastave matematike*  
*partial differential equations; micropolar fluids; numerical analysis; statistical analysis; methodology of teaching mathematics*



**Loredana Simčić**

*mikropolarni fluidi; kombinatorna i diskretna matematika*  
*micropolar fluids; combinatorial and discrete mathematics*



**Tomislav Žic**

*fizika; astrofizika; fizika Sunca; magnetohidrodinamika (MHD); numeričko MHD modeliranje; koronini izbačaji mase; svemirska prognostika; modeliranje udarnih valovova u Sunčevoj atmosferi, koroni i međuplanetarnom prostoru;*  
*physics; solar physics; magnetohydrodynamics (MHD); numerical MHD modelling; coronal mass ejections; space weather; shock waves modelling in solar atmosphere, corona and interplanetary space*

### VIŠI PREDAVAČI | SENIOR LECTURERS



**Melita Štefan Trubić**

*numerička matematika; metodika nastave matematike*  
*numerical mathematics; methodology of teaching mathematics*

### PREDAVAČI | LECTURERS

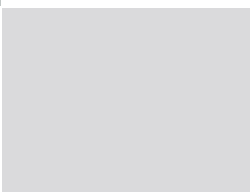

**Elisa Velčić Janjetić**

*njemački jezik i književnost; engleski jezik i književnost; jezik struke*  
*german language and literature; english language and literature; professional language*



**Anita Badurina**

*njemački jezik i književnost; engleski jezik i književnost; jezik struke*  
*german language and literature; english language and literature; professional language*



**Vanja Čotić Poturić**

*metodika nastave matematike*  
*methodology of teaching mathematics*



**Igor Lulić**

*matematika*  
*mathematics*

### ASISTENTICA | ASSISTANT

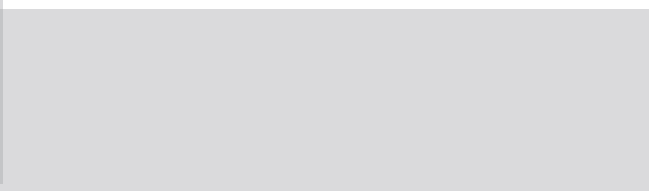

**Angela Bašić - Šiško**

*numerička matematika*  
*numerical mathematics*



**Julijan Dobrinić**

*fizika; zaštita okoliša*  
*physics; environmental protection*

### PROFESOR EMERITUS | PROFESSOR EMERITUS

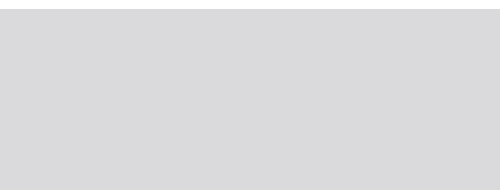

## VANJSKI SURADNICI | ASSOCIATES

## Vedran Vujnović

Odjel za fiziku Sveučilišta u Rijeci  
| Department of Physics, University of Rijeka

## Tomislav Jurkić

Odjel za fiziku Sveučilišta u Rijeci  
| Department of Physics, University of Rijeka

fizika

physics

## Senka Maćešić

Sveučilište u Rijeci | University of Rijeka

## Sara Ban

Odjel za matematiku Sveučilišta u Rijeci  
| Department of Mathematics, University of Rijeka

## Nevena Jurčević Peček

Odjel za matematiku Sveučilišta u Rijeci  
| Department of Mathematics, University of Rijeka

## Emma Šepić

Odjel za matematiku Sveučilišta u Rijeci  
| Department of Mathematics, University of Rijeka

## Matteo Mravić

Odjel za matematiku Sveučilišta u Rijeci  
| Department of Mathematics, University of Rijeka

## Bojan Ostić

Odjel za matematiku Sveučilišta u Rijeci  
| Department of Mathematics, University of Rijeka

matematika

mathematics

## nastava i znanost education and science

Nastava matematičkih kolegija izvodi se za inženjere s odabranim poglavljima iz područja linearnе algebre, matematičke analize, diferencijalnih jednadžbi, vjerojatnosti i statistike te numeričke i stohastičke matematike. Nastava fizikalnih kolegija izvodi se za inženjere s odbranim poglavljima iz moderne fizike i zaštite okoliša. Nastava engleskog i njemačkog jezika obuhvaća obrađivanje odabranih poglavlja iz područja strojarstva, brodogradnje, elektrotehnike i računarstva te usavršavanje stručnog vokabulara i gramatičkih struktura jezika tehnike.

Mathematical lectures for engineers with selected chapters in the fields of: linear algebra, mathematical analysis, differential equations, probability and statistics, numerical and stochastic mathematics. Physics lectures for engineers with selected chapters in modern physics and environment protection. The English and German Language courses of study cover the analysis of selected chapters in the field of Mechanical Engineering, Naval Architecture, Electrical Engineering and Computer Science as well as the enhancement of professional-technical vocabulary and grammar.

## KOLEGIJI NA PREDDIPLOMSKIM SVEUČILIŠNIM STUDIJIMA

| UNDERGRADUATE UNIVERSITY COURSES

- Matematika 1
- Matematika 2
- Inženjerska matematika ET
- Inženjerska statistika
- Inženjerska matematika R
- Uvod u modernu fiziku
- Fizika 1
- Fizika 2
- Engleski jezik I
- Engleski jezik II
- Njemački jezik I
- Njemački jezik II
- Tjelesna i zdravstvena kultura I
- Tjelesna i zdravstvena kultura II

- Mathematics 1
- Mathematics 2
- Engineering mathematics ET
- Statistics for engineers
- Engineering mathematics R
- Introduction to modern physics
- Physics 1
- Physics 2
- English Language I
- English Language II
- German Language I
- German Language II
- Physical and Health Education I
- Physical and Health Education II

## KOLEGIJI NA DIPLOMSKIM SVEUČILIŠNIM STUDIJIMA

| GRADUATE UNIVERSITY COURSES

- Inženjerska matematika
- Numerička i stohastička matematika
- Stohastička matematika
- Engineering mathematics
- Numerical and stochastic mathematics
- Stochastic mathematics

## KOLEGIJI NA PREDDIPLOMSKIM STRUČNIM STUDIJIMA

| UNDERGRADUATE VOCATIONAL COURSES

- Matematika 1
- Matematika 2
- Fizika
- Engleski jezik I
- Engleski jezik II
- Njemački jezik I
- Njemački jezik II
- Tjelesna i zdravstvena kultura I
- Tjelesna i zdravstvena kultura II
- Mathematics 1
- Mathematics 2
- Physics
- English Language I
- English Language II
- German Language I
- German Language II
- Physical and Health Education I
- Physical and Health Education II

## KOLEGIJI NA POSLIJEDIPLOMSKIM (DOKTORSKIM) SVEUČILIŠNIM STUDIJIMA

| POSTGRADUATE UNIVERSITY (DOCTORAL) COURSES

- Statističke metode i stohastički procesi
- Matematičko modeliranje i numeričke metode
- Metode optimizacije
- Izabrana poglavlja iz zaštite okoliša
- Instrumentacija i analitičke tehnike u zaštiti okoliša
- Kemija okoliša
- Zaštita mora i priobalja
- Statistical Methods and Stochastic Processes
- Mathematical Modeling and Numerical Methods
- Optimization Methods
- Selected Topics on Environment Protection
- Instrumentation and Analytical Techniques in Environment Protection
- Environmental Chemistry
- Protection of Sea and Coastal Zone

## ZNAJSTVENOISTRAŽIVAČKI RAD | SCIENTIFIC RESEARCH

- parcijalne diferencijalne jednadžbe, numerička matematika, matematičko modeliranje, optimizacija, operacijska istraživanja, statističke metode, kombinatorna i diskretna matematika, dinamički sustavi, didaktika nastave matematike  
partial differential equations, numerical mathematics, mathematical modeling, optimization, operational research, statistical methods, combinatorial and discrete mathematics, dynamical systems, didactic of mathematics
- zaštita okoliša, atomska i nuklearna fizika  
environment protection, atomic and nuclear physics
- njemački i engleski jezik kao jezik struke; istraživanje uvjeta za implementaciju engleskoga jezika kao jezika poučavanja u visokom školstvu  
German and English as languages for specific purposes (LSP), the study of the conditions for the implementation of English-medium Instruction (EMI) in higher education
- astrofizika, fizika Sunca: magnetohidrodinamika (MHD); numeričko modeliranje  
astrophysics, solar physics; magnetohydrodynamics (MHD); numerical modelling

## PROJEKTI | PROJECTS

- Analiza matematičkih modela mehanike fluida i tehničkih sustava pomoću podacima vođenih algoritama za Koopmanov operator", istraživanje uz potporu Sveučilišta u Rijeci, voditeljica Nelida Črnjarić-Žic, suradnici Senka Maćešić, Ivan Dražić, Loredana Simčić, Angela Bašić-Šiško

*Analysis of mathematical models of fluid mechanics and technical systems using data-driven algorithms for Koopman operator", research supported by the University of Rijeka, principal investigator Nelida Črnjarić-Žic, collaborators Senka Maćešić, Ivan Dražić, Loredana Simčić, Angela Bašić-Šiško*

- *Višeskalni problemi u mehanici fluida", projekt HRZZ-a, voditelj prof. Igor Pažanin, PMF - matematički odsjek Sveučilišta u Zagrebu, suradnik Ivan Dražić*  
*Multiscale problems in fluid mechanics", HRZZ project, principal investigator prof. Igor Pažanin, PMF - mathematical department University of Zagreb, collaborator Ivan Dražić*

#### PUBLIKACIJE | PUBLICATIONS

##### KNJIGE | BOOKS

- *Maćešić, S.; Črnjarić-Žic, N. Koopman Operator Theory for Nonautonomous and Stochastic Systems - poglavlje u knjizi: The Koopman Operator in Systems and Control, urednici Mauroy, A., Mezić I., Susuki Y., Springer, 0170-8643, 2020, Switzerland*

##### RADOVI U ČASOPISIMA | JOURNAL PAPERS

- *Črnjarić-Žic, N.; Maćešić, S.; Mezić, I. Koopman Operator Spectrum for Random Dynamical Systems, SIAM, Journal on nonlinear science, 0938-8974, 09582-z, 1-50, 2019*
- *Simčić, L. A shear flow problem for compressible viscous micropolar fluid: Uniqueness of a generalized solution, Mathematical methods in the applied sciences, 0170-4214, 42, 6358-6368 2019*
- *Velčić Janjetić, E.; Badurina, A. Implementing Alternative Assessment in ESP Classes, Conference Proceedings, IV. International Conference From Theory to Practice in Language for Specific Purposes, 1849-9279, 4, 348-358, 2020*

##### MEĐUNARODNI KONGRESI | INTERNATIONAL CONGRESSES

- *Bašić-Šiško A.; Dražić I. Local Solvability for Micropolar Real Gas Flow Model, ApplMath20 - Tenth Conference on Applied, Mathematics and Scientific Computing, 2020, Brijuni, Hrvatska*
- *Bašić-Šiško A. Compressible Micropolar Fluid Flow - Solvability of the Model, My First Conference 2020, 2020, Sveučilište u Rijeci, Tehnički Fakultet, Rijeka, Hrvatska*

##### MEĐUNARODNA SURADNJA | INTERNATIONAL COLLABORATIONS

- *University of California, Santa Barbara, SAD, USA*

5<sup>7</sup>

**zavod za materijale**  
**department of materials science**  
**and engineering**



## djelatnici faculty and staff

### PREDSTOJNIK ZAVODA | DEPARTMENT HEAD:



Doc. dr. sc. / Assist. Prof. D. Sc. Dario Ilkić

*materijali; tehnologija materijala; materijali i tehnološki postupci; postupci toplinske obrade; metalni materijali; ljevarstvo; ispitivanje materijala i analiza loma*

*materials; technology of material; materials and technological processes; processes of heat treatment; metallic materials; casting; materials testing and fracture analysis*

### DOCENTICA | ASSISTANT PROFESSOR



Sunčana Smokvina Hanza

*materijali; tehnologija materijala; postupci toplinske obrade; materijali i tehnološki postupci; ispitivanje materijala i analiza loma; karakterizacija materijala; zaštita materijala*

*materials; technology of material; processes of heat treatment; materials and technological processes; materials testing and fracture analysis; materials characterisation; materials protection*

### ASISTENTI | ASSISTANTS



Lovro Liverić

*materijali; tehnologija materijala; postupci toplinske obrade; materijali i tehnološki postupci*

*materials; technology of material; processes of heat treatment; materials and technological processes*



Lovro Štic

*materijali; tehnologija materijala; postupci toplinske obrade; materijali i tehnološki postupci; zaštita materijala; ispitivanje materijala*

*materials; technology of material; processes of heat treatment; materials and technological processes; materials protection*

### PROFESOR EMERITUS | PROFESSOR EMERITUS

Ivan Katavić



*materijali; tehnologija materijala; materijali i tehnološki postupci; metalni materijali; ljevarstvo; karakterizacija materijala; ispitivanje materijala*  
*materials; technology of material; materials and technological processes; metallic materials; casting; materials characterisation; materials testing*

### VANJSKI SURADNICI | ASSOCIATES

Leszek Adam Dobrzanski

Silesian University of Technology, Gliwice

*materijali; tehnologija materijala; materijali i tehnološki postupci; metalni materijali; nemetalni materijali; zaštita materijala; ljevarstvo; karakterizacija materijala; mehanika materijala; toplinska obrada i inženjerstvo površina; mehanika prijeloma i umorljivost; ispitivanje materijala; selekcija materijala; procesi oštećivanja materijala; kemija materijala; korozija i zaštita metala*

*materials; technology of material; materials and technological processes; metallic materials; nonmetal materials; materials protection; casting; materials characterisation; materials mechanics; heat treatment and surface engineering; fracture mechanics and fatigue of materials; materials testing; materials selection; processes of damaging of materials; materials chemistry; corrosion and metals protection*

Robert Danzer

Institut für Struktur- und Funktionskeramik

*keramički i kompozitni materijali*

*ceramics and composite materials*

Vojteh Leskovšek

IMT Ljubljana

*karakterizacija materijala; toplinska obrada i inženjerstvo površina; mehanika prijeloma i umorljivost*

*materials characterisation; heat treatment and surface engineering; fracture mechanics and fatigue of materials*

Domagoj Rubeša

FH JOANNEUM, University of Applied Sciences, Graz

*mehanika materijala; mehanika prijeloma i umorljivost; selekcija materijala; procesi oštećivanja materijala*

*materials mechanics; fracture mechanics and fatigue of materials; materials selection; processes of damaging of materials*

Neven Tomašić

RENETEH Ogulin d.o.o.

*materijali; tehnologija materijala; materijali i tehnološki postupci; postupci toplinske obrade; metalni materijali*

*materials; technology of material; materials and technological processes; processes of heat treatment; metallic materials*

## nastava i znanost education and science

*Nastava se izvodi iz područja materijala, tehnologije materijala, materijala i tehnoloških postupaka, karakterizacije materijala, metalnih materijala, nemetalnih materijala, zaštite materijala, mehaničkog ponašanja i odabira materijala, termalnih procesa materijala, ispitivanja materijala i analize loma, procesa oštećivanja materijala, kemije materijala, korozije i zaštite metala.*

*Lectures in the field of materials, technology of materials, materials and technological processes, materials characterisation, metallic materials, nonmetal materials, materials protection, mechanical behaviour and selection of materials, thermal processes of materials, materials testing and fracture analysis, processes of damaging of materials, materials chemistry, corrosion and metals protection.*

**KOLEGIJI NA PREDDIPLOMSKIM SVEUČILIŠNIM STUDIJIMA**

## | UNDERGRADUATE UNIVERSITY COURSES

- |  |  |
|--|--|
| • <i>Materijali I</i>                    | • <i>Materials I</i>                     |
| • <i>Materijali II</i>                   | • <i>Materials II</i>                    |
| • <i>Tehnologija materijala</i>          | • <i>Technology of Material</i>          |
| • <i>Izborni projekt - Materijali I</i>  | • <i>Elective project - Materials I</i>  |
| • <i>Izborni projekt - Materijali II</i> | • <i>Elective project - Materials II</i> |
| • <i>Karakterizacija materijala</i>      | • <i>Materials Characterisation</i>      |
| • <i>Postupci toplinske obrade</i>       | • <i>Processes of Heat Treatment</i>     |

**KOLEGIJI NA DIPLOMSKIM SVEUČILIŠNIM STUDIJIMA**

## | GRADUATE UNIVERSITY COURSES

- |   |  |
|---|--|
| • <i>Metalni materijali</i>                       | • <i>Metallic Materials</i>                              |
| • <i>Nemetalni materijali</i>                     | • <i>Nonmetallic Materials</i>                           |
| • <i>Zaštita materijala</i>                       | • <i>Materials Protection</i>                            |
| • <i>Projekt I - Zaštita materijala</i>           | • <i>Project I - Materials Protection</i>                |
| • <i>Projekt I - Metalni materijali</i>           | • <i>Project I - Metallic Materials</i>                  |
| • <i>Ispitivanje materijala i analiza loma</i>    | • <i>Materials Testing and Fracture Analysis</i>         |
| • <i>Termalni procesi materijala</i>              | • <i>Thermal Processes of Materials</i>                  |
| • <i>Projekt II - Termalni procesi materijala</i> | • <i>Project II - Thermal Processes of Materials</i>     |
| • <i>Mehaničko ponašanje i odabir materijala</i>  | • <i>Mechanical Behaviour and Selection of Materials</i> |

**KOLEGIJI NA PREDDIPLOMSKIM STRUČNIM STUDIJIMA**

## | UNDERGRADUATE VOCATIONAL COURSES

- |   |  |
|---|--|
| • <i>Materijali</i>                       | • <i>Materials</i>                             |
| • <i>Materijali i tehnološki postupci</i> | • <i>Materials and Technological Processes</i> |

**KOLEGIJI NA POSLIJEDIPLOMSKIM (DOKTORSKIM) SVEUČILIŠNIM STUDIJIMA**

## | POSTGRADUATE UNIVERSITY (DOCTORAL) COURSES

- |   |  |
|---|--|
| • <i>Procesi oštećivanja materijala</i>               | • <i>Processes of Damaging of Materials</i>          |
| • <i>Mehanika prijeloma i umorljivost</i>             | • <i>Fracture Mechanics and Fatigue of Materials</i> |
| • <i>Korozija i zaštita materijala</i>                | • <i>Corrosion and Metals Protection</i>             |
| • <i>Toplinska obrada i inženjerstvo površina</i>     | • <i>Heat Treatment and Surface Engineering</i>      |
| • <i>Izabrana poglavlja iz ispitivanja materijala</i> | • <i>Selected Chapters on Material Testing</i>       |

**ZNANSTVENOISTRAŽIVAČKI RAD | SCIENTIFIC RESEARCH**

- *Znanstvenoistraživački rad iz znanstvenog područja tehničke znanosti, znanstvenih polja strojarstvo i temeljne tehničke znanosti, znanstvenih grana proizvodno strojarstvo i materijali. Research and development activities in the scientific area of Technical Sciences, scientific fields of Mechanical Engineering and Fundamental Engineering Sciences, scientific branches of Mechanical Production Engineering and Materials*

**MEĐUNARODNI KONGRESI | INTERNATIONAL CONGRESSES**

- *Smoljan, B.; Iljkić, D. Mathematical Modeling and Computer Simulation of Steel Quenching The 7th International Conference on Modern Manufacturing Technologies in Industrial Engineering, 1757-8981, 101, 2019., Iasi, Rumunjska*
- *Maretić, M.; Iljkić, D.; Smokvina Hanza, S.; Jokić, M.; Pomenić, L.; Smoljan, B. Electroless nickel-phosphorous layers on austenitic stainless steel substrate, Conference Proceedings 20th International Conference on Materials, MATRIB 2019, 2459-5608, 213-221, 2019., Vela Luka*
- *Basan, R.; Marohnić, T.; Smokvina Hanza, S. Pregled postojećih pristupa i metoda za procjenu cikličkih i zamornih parametara materijala, Conference Proceedings 20th International Conference on Materials, MATRIB 2019, 2459-5608, 42-51, 2019., Vela Luka*

**MEĐUNARODNA SURADNJA | INTERNATIONAL COLLABORATIONS**

- *Faculty of Mechanical Engineering, University of Ljubljana, Ljubljana, Slovenija, Slovenia*
- *Institute of Metals and Technology, Ljubljana, Slovenija, Slovenia*
- *John von Neumann Faculty of Informatics, Obuda University, Mađarska, Hungary*
- *Materials Engineering, Silesian University of Technology in Gliwice, Gliwice, Poljska, Poland*

**5.8**

**zavod za mehaniku fluida i računarsko inženjerstvo**  
**department of fluid mechanics and computational engineering**





## djelatnici faculty and staff

### PREDSTOJNIK ZAVODA | DEPARTMENT HEAD:



Prof. dr. sc. / Prof. D. Sc. **Lado Kranjčević**

*strujanje u mreži cjevovoda; strujanje u otvorenim vodotocima;  
paralelno programiranje*

*pipe network flow; open channel flow; parallel programming*

### REDOVITI PROFESOR | PROFESSOR



**Zoran Čarija**

*analiza i optimizacija hidrauličkih sustava; analiza i optimizacija strujanja  
u hidroturbinama; strujanje sa slobodnom površinom*

*hydraulic systems analysis and optimization; hydroturbine flow analysis  
and optimization; free surface fluid flow*

### IZVANREDNI PROFESORI | ASSOCIATE PROFESSORS



**Siniša Družeta**

*analiza i optimizacija hidrauličkih sustava; strujanje u otvorenim  
vodotocima; optimizacijske metode*

*hydraulic systems analysis and optimization; open channel flow;  
optimization methods*



**Jerko Škifić**

*hidraulički tranzijenti; analiza i optimizacija hidrauličkih sustava;  
programiranje tehničkih aplikacija*

*hydraulic transients; hydraulic systems analysis and  
optimization; technical software development*

### DOCENT | ASSISTANT PROFESSOR



**Stefan Ivić**

*programiranje tehničkih aplikacija; polaganje cjevovoda;  
optimizacija*

*technical software development; pipe laying; optimization*

### ASISTENTI | ASSISTANTS

**Luka Grbčić**

*primjena strojnog učenja i umjetne inteligencije u inženjerstvu;  
računarska dinamika fluida; modeliranje miješanja turbulentnog fluida  
machine learning and AI applications in engineering; computational fluid  
dynamics; turbulent fluid mixing modeling*

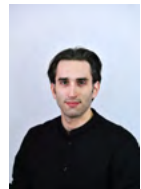

**Ivana Lučin**

*3D modeliranje u računalnoj mehanici fluida; strojno učenje  
3D modelling in CFD; machine learning*



## nastava i znanost education and science

*Nastava iz područja: mehanika fluida,  
hidraulički strojevi, računalne metode,  
numeričko modeliranje, optimizacija.*

CO: Primjena računarskih metoda

*Lectures in the field of: fluid mechanics,  
hydraulic machines, computational  
methods, numerical modeling,  
optimization.*

LLL: Applied Computational Methods

### KOLEGIJI NA PREDDIPLOMSKIM SVEUČILIŠNIM STUDIJIMA

| UNDERGRADUATE UNIVERSITY COURSES

- Primjena računala u inženjerstvu
- Uvod u računarstvo
- Mehanika fluida
- Računarske metode
- Hidraulički strojevi
- Računalne simulacije u tehnici
- Računarsko inženjerstvo
- Programiranje
- Računalna grafika
- Computer Applications in Engineering
- Introduction to Computer Science
- Fluid Mechanics
- Computational Methods
- Hydraulic Machines
- Computer Simulations in Engineering
- Computational Engineering
- Programming
- Computer Graphics

### KOLEGIJI NA DIPLOMSKIM SVEUČILIŠNIM STUDIJIMA

| GRADUATE UNIVERSITY COURSES

- Analiza sustava i podataka
- Dinamika fluida
- Modeliranje u tehnici
- Numeričko modeliranje hidrauličkih strojeva
- Optimizacije u tehnici
- Primjena paralelnog računanja
- Primjena računalne grafike
- Programiranje tehničkih aplikacija
- Programiranje tehničkih aplikacija II
- Računalom podržano mjerenje
- Računalna mehanika fluida
- System and Data Analysis
- Fluid Dynamics
- Models in Engineering
- Numerical Modeling of Hydraulic Machines
- Optimization in Technics
- Applied Parallel Computing
- Applied Computer Graphics
- Programming of Technical Applications
- Programming of Technical Applications II
- Computer Aided Measuring
- Computational Fluid Dynamics

- *Upoznavanje industrijskih postrojenja*
- *Računarske metode u brodogradnji*
- *Insight to Industrial Facilities*
- *Computational Methods in Naval Engineering*

**KOLEGIJI NA PREDDIPLOMSKIM STRUČNIM STUDIJIMA**

| UNDERGRADUATE VOCATIONAL COURSES

- *Hidraulički strojevi ST*
- *Mehanika fluida ST*
- *Hydraulic Machines ST*
- *Fluid Mechanics ST*

**KOLEGIJI NA POSLIJEDIPLOMSKIM SVEUČILIŠNIM (DOKTORSKIM) STUDIJIMA**

| POSTGRADUATE UNIVERSITY (DOCTORAL) COURSES

- *Dinamika fluida*
- *Hidrodinamika turbostrojeva*
- *Turbulentno strujanje*
- *Modeliranje onečišćenja zraka*
- *Računalna mehanika fluida*
- *Modeliranje strujanja sa slobodnom površinom*
- *Modeliranje nestacionarnog strujanja u cjevovodu*
- *Fluid Dynamics*
- *Hydrodynamics of Turbomachines*
- *Turbulent Flow*
- *Air Quality Modeling*
- *Computational Fluid Mechanics*
- *Free Surface Flow Modeling*
- *Unsteady Pipe Flow Modeling*

**ZNANSTVENOISTRAŽIVAČKI RAD | SCIENTIFIC RESEARCH**

- *Strujanje u priobalnom području*  
*Coastal flow*
- *Strujanje u otvorenim vodotocima*  
*Open channel flow*
- *Analiza i optimizacija hidrauličkih sustava*  
*Hydraulic systems analysis and optimization*
- *Hidraulički tranzijenti*  
*Hydraulic transients*
- *Strujanje u cjevovodima*  
*Pipe flow*
- *Optimizacijske metode*  
*Optimization methods*
- *Hibridno 2D/3D modeliranje strujanja sa slobodnom površinom*  
*Hybrid 2D/3D free surface flow modeling*
- *Predikcija mikrobiološke kakvoće vode upotrebom strojnog učenja*  
*Microbiological water quality prediction using machine learning*

**PROJEKTI | PROJECTS**

- *KLIMOD - Računalni model strujanja, poplavlivanja i širenja onečišćenja u rijekama i obalnim morskim područjima 01/2020-01/2023 (KK.05.1.1.02.0017)*  
*KLIMOD - A computational model of flow, flooding and pollution dispersion in rivers and coastal marine areas 01/2020-01/2023 (KK.05.1.1.02.0017)*
- *L. Kranjčević, Razvoj hibridnog 2D/3D modela za učinkovito modeliranje strujanja u rijekama, jezerima i morima - projekt uz potporu Sveučilišta, Tehnički fakultet Sveučilišta u Rijeci, 2019/2020.*  
*Hybrid 2D/3D model development for efficient flow modelling in rivers, lakes and oceans - project supported by University of Rijeka, Faculty of Engineering University of Rijeka, 2019/2020.*

**PUBLIKACIJE | PUBLICATIONS****RADOVI U ČASOPISIMA | JOURNAL PAPERS**

- *Bosner, T.; Crnković, B.; Škifić, J. Application of CCC–Schoenberg operators on image resampling, BIT Numerical Mathematics, 1572-9125, 60, 129–155, 2020, Lund, Švedska*
- *Stipanić, D.; Travaš, V.; Kranjčević, L.; Holjević, D. An Iterative Algorithm for Optimizing Pipe Diameter in Pressurized System, Tehnički vjesnik, 1848-6339, 4, 1284-1292, 2020, Osijek, Hrvatska*
- *Milošević, T.; Kranjčević, L.; Piličić, S.; Čavrak, M.; Kegali, I.; Traven, L. Air Pollution Dispersion Modeling in Port Areas, Pomorski zbornik, 0554-6397, 3, 157-170, 2020, Rijeka, Hrvatska*
- *Kranjčević, L.; Grbčić, L.; Mrazović, M.; Družeta, S. Rijeka Bay 3D VOF Costal Flow Model, Pomorski zbornik, 0554-6397, 3, 125-132, 2020, Rijeka, Hrvatska*
- *Grbčić, L.; Kranjčević, L.; Filiplić, I.; Mavrić, K. Numerical Simulation of River Inflows in Rijeka Bay Coastal Area, Pomorski zbornik, 0554-6397, 3, 117-124, 2020, Rijeka, Hrvatska*
- *Haber Mrša, I.; Legović, T.; Kranjčević, L.; Cukrov, M. Simulation of pollutants spreading from a sewage outfall in the Rijeka Bay, Mediterranean Marine Science, 1791-6763, 21, 116-128, 2020, Grčka*
- *Kovač, I.; Šrajbek, M.; Kranjčević, L.; Novotni-Horčička, N. Nonlinear models of the dependence of nitrate concentrations on the pumping rate of a water supply system, Geosciences Journal, 1598-7477, 24, 585-595, 2020, Korea*
- *Sikirica, A.; Čarija, Z.; Kranjčević, L.; Lučin, I. Grid type and turbulence model influence on propeller characteristics prediction, Journal of Marine Science and Engineering, 2077-1312, 7(11), 374, 2019, Basel, Švicarska*
- *Lučin, I.; Čarija, Z.; Grbčić, L.; Kranjčević, L. Assessment of head loss coefficients for water turbine intake trash-racks by numerical modeling, Journal of Advanced Research, 2090-1232, 21, 109-119, 2020, Kairo, Egipat*
- *Grbčić, L.; Kranjčević, L.; Družeta, S.; Lučin, I. Efficient Double-Tee Junction Mixing Assessment by Machine Learning, Water, 2073-4441, 12(1), 238, 2020, Basel, Švicarska*
- *Grbčić, L.; Lučin, I.; Kranjčević, L.; Družeta, S. A Machine Learning-based Algorithm for Water Network Contamination Source Localization Sensors, 1424-8220, 20(9), 2613, 2020, Basel, Švicarska*
- *Sikirica, A.; Lučin, I.; Čarija, Z.; Lučin, B. CFD Analysis of Marine Propeller Configurations in Cavitating Conditions, Pomorski zbornik, 0554-6397, Special edition (3), 251-264, 2020 Rijeka, Hrvatska*
- *Družeta, S.; Ivić, S.; Grbčić, L.; Lučin, I. Introducing languid particle dynamics to a selection of PSO variants, Egyptian Informatics Journal, 1110-8665, 21 (2), 119-129, 2020, Kairo, Egipat*
- *Grbčić, L.; Kranjčević, L.; Lučin, I.; Sikirica, A. Large Eddy Simulation of turbulent fluid mixing in double-tee junctions, Ain Shams Engineering Journal, 2090-4479, 2020, Kairo, Egipat*
- *Vidas, J.; Šnjarić, D.; Braut, A.; Čarija, Z.; Peršić Bukmir, R.; J.G. De Moor, R.; Brekalo Pršo, I. Comparison of apical irrigant solution extrusion among conventional and laser-activated endodontic irrigation, Lasers in Medical Science, 0268-8921, 35(1), 205-211, 2020, London, Velika Britanija*
- *Čarija, Z.; Ledić, F.; Sikirica, A.; Niceno, B. CFD study of the PTS experiment in ROCOM test facility, Nuclear Engineering and Technology, 1738-5733, 2020, Južna Koreja*



- Prpić-Oršić, J.; Valčić, M.; Čarija, Z. A Hybrid Wind Load Estimation Method for Container Ship Based on Computational Fluid Dynamics and Neural Networks, *Journal of Marine Science and Engineering*, 2077-1312, 8(7), 539, 2020, Basel, Švicarska
- Vidas, J.; Šnjarić, D.; Braut, A.; Čarija, Z.; Peršić Bukmir, R.; J.G. De Moor, R.; Brekalo Pršo, I. Comparison of apical irrigant solution extrusion among conventional and laser-activated endodontic irrigation, *Lasers in Medical Science*, 0268-8921, 35(1), 205-211, 2020, London, Velika Britanija
- Čarija, Z.; Ledić, F.; Sikirica, A.; Niceno, B. CFD study of the PTS experiment in ROCOM test facility, *Nuclear Engineering and Technology*, 1738-5733, 2020, Južna Koreja
- Prpić-Oršić, J.; Valčić, M.; Čarija, Z. A Hybrid Wind Load Estimation Method for Container Ship Based on Computational Fluid Dynamics and Neural Networks, *Journal of Marine Science and Engineering*, 2077-1312, 8(7), 539, 2020, Basel, Švicarska

**MEDUNARODNI KONGRESI | INTERNATIONAL CONGRESSES**

- Hao Zeng, Lado Kranjčević, Lado Kranjčević, An Approach to Couple Shallow Water and Navier-Stokes Suted for Upstream-Travelling Shock Waves Based on Openfoam Framework - Shallowinterfoam, 38th IAHR World Congress (Panama), 2019
- Teodora Milošević, Lado Kranjčević, Stjepan Piličić, Marko Čavrak, Igor Kegali, Luka Traven Air Pollution Dispersion Modeling in Port Areas "EIGHTH INTERNATIONAL CONFERENCE ON MARINE TECHNOLOGY in memoriam of the academician Zlatko Winkler", 2019, Rijeka, Hrvatska
- Lado Kranjčević, Luka Grbčić, Matija Mrazović, Siniša Družeta, Rijeka Bay 3D VOF Costal Flow Model, "EIGHTH INTERNATIONAL CONFERENCE ON MARINE TECHNOLOGY in memoriam of the academician Zlatko Winkler", 2019, Rijeka, Hrvatska
- Luka Grbčić, Lado Kranjčević, Ivan Filipčić, Kristijan Mavrić, Numerical Simulation of River Inflows in Rijeka Bay Coastal Area, "EIGHTH INTERNATIONAL CONFERENCE ON MARINE TECHNOLOGY in memoriam of the academician Zlatko Winkler", 2019, Rijeka, Hrvatska
- Ante Sikirica, Ivana Lučin, Zoran Čarija, Bože Lučin, CFD Analysis of Marine Propeller Configurations in Cavitating Conditions, "EIGHTH INTERNATIONAL CONFERENCE ON MARINE TECHNOLOGY in memoriam of the academician Zlatko Winkler", 2019, Rijeka, Hrvatska
- Ivana Lučin, Luka Grbčić, Martin Zlatić, Lado Kranjčević, COMPARISON OF SPH AND VOF NUMERICAL MODELS ON DTC HULL, "EIGHTH INTERNATIONAL CONFERENCE ON MARINE TECHNOLOGY in memoriam of the academician Zlatko Winkler", 2019, Rijeka, Hrvatska

**MEDUNARODNA SURADNJA | INTERNATIONAL COLLABORATIONS**

- Technische Universität München, Ingenieur fakultät Bau Geo Umwelt, Njemačka, Germany
- Technical University of Denmark - DTU, Danska, Denmark

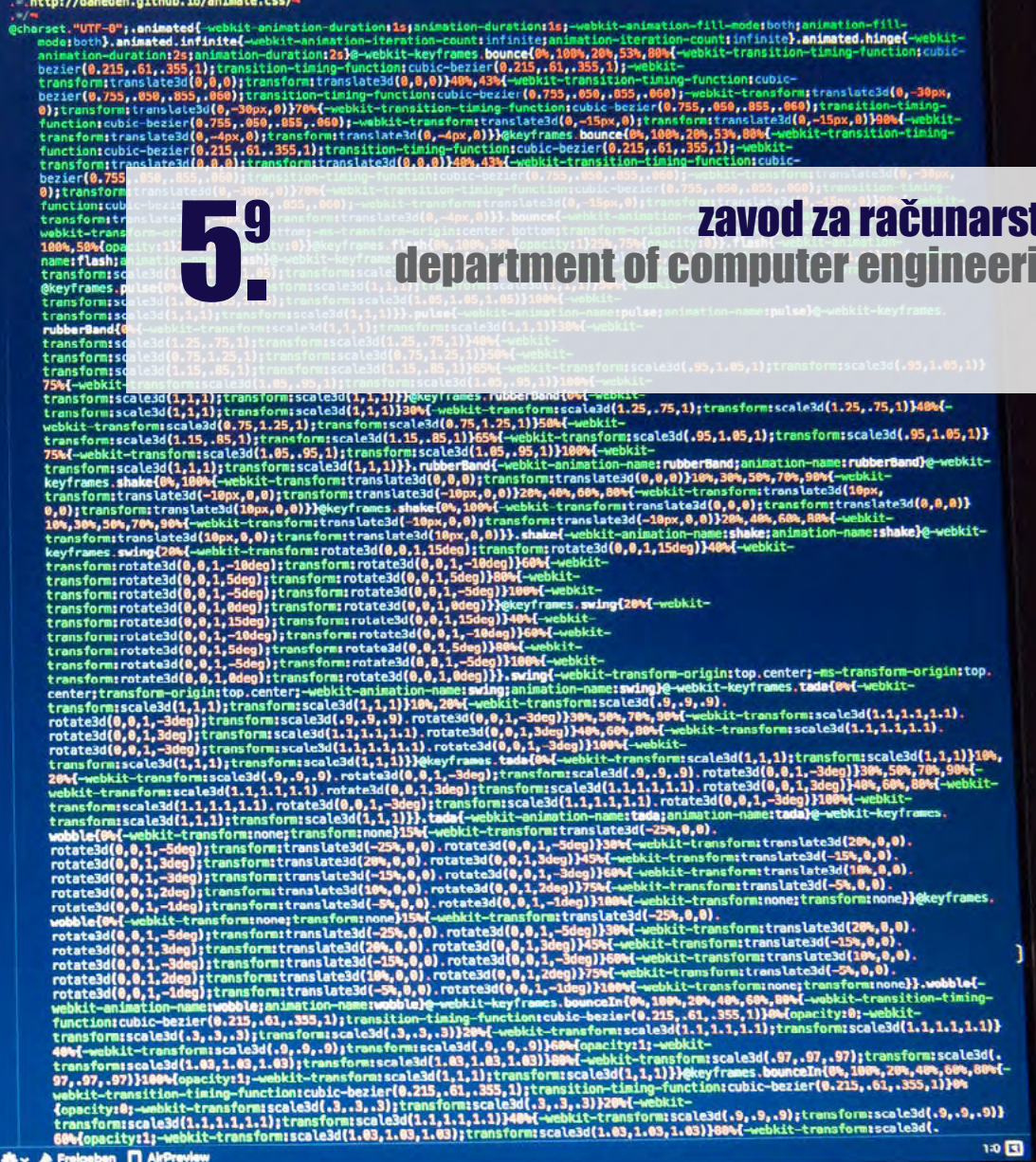

59

zavod za računarstvo  
department of computer engineering



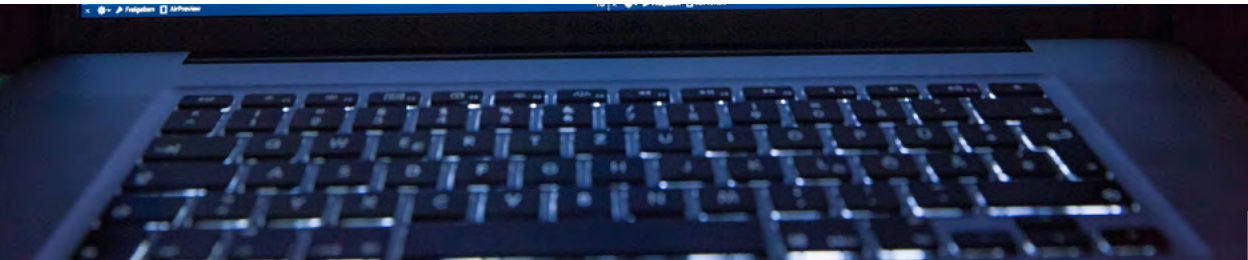

## djelatnici faculty and staff

### PREDSTOJNIK ZAVODA | DEPARTMENT HEAD:



Doc. dr. sc. / Assist. Prof. D. Sc. Jonatan Lerga

*digitalna obrada signala; teorija informacija; kodiranje; kriptografija; umjetna inteligencija*

*digital signal processing; information theory; coding; cryptography; artificial intelligence*

### REDOVITI PROFESOR U TRAJNOM ZVANJU | TENURED PROFESSOR



Ivo Ipšić

*umjetna inteligencija; raspoznavanje uzoraka; govorne tehnologije*  
*artificial intelligence; pattern recognition; speech technologies*

### REDOVITI PROFESOR | PROFESSOR



Miroslav Joler

*antene; visokofrekvencijska elektronika; bežične komunikacije; računalni elektromagnetizam; rekonfigurabilni sklopovi*  
*antennas; high-frequency electronics; wireless communications; computational electromagnetics; reconfigurable circuits*

### IZVANREDNI PROFESORI | ASSOCIATE PROFESSORS



Kristijan Lenac

*mobilna robotika; operacijski sustavi; ugradbeni sustavi; blockchain*  
*mobile robotics; operating systems; embedded systems; blockchain*

Ivan Štajduhar

*umjetna inteligencija; strojno učenje*  
*artificial intelligence; machine learning*



Mladen Tomić

*digitalna obrada signala i slike; teorija valića; filterski slogovi*  
*digital signal and image processing; wavelets; filter banks*

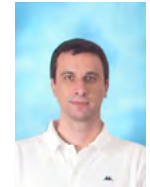

### DOCENTI | ASSISTANT PROFESSORS

Damir Arbula

*bežične mreže osjetila; raspodjeljeni algoritmi; lokalizacija*  
*wireless sensor networks; distributed algorithms; localization*



Sandi Ljubić

*interakcija čovjeka i računala; mobilne aplikacije; inženjerstvo upotrebljivosti; empirijsko vrednovanje interaktivnih sustava*  
*human-computer interaction (HCI); mobile applications; usability engineering; interactive systems empirical evaluation*



Goran Mauša

*umjetna inteligencija; primijenjeno meko računarstvo; predviđanje programskih neispravnosti*  
*artificial intelligence; applied soft computing; software defect prediction*



### ASISTENTI | ASSISTANTS

David Bačnar

*spektralna analiza signala; bežične i radio komunikacije*  
*spectral signal analysis; wireless and radio communications*



Luka Batistić

*interakcija čovjeka i računala; digitalna obrada signala*  
*human-computer interaction (HCI); digital signal processing*



## Franko Hrzić



*umjetna inteligencija; strojno učenje*  
*artificial intelligence; machine learning*

## Guruprasad Madhale Jadav



*neuroznanosti; digitalna obrada signala*  
*neuroscience; digital signal processing*

## Alen Salkanović



*interakcija čovjeka i računala; mobilne aplikacije*  
*human-computer interaction (HCI); mobile applications*

## Denis Selimović



*vremensko-frekvencijska analiza signala; teorija informacija*  
*time-frequency signal analysis; information theory*

## Matija Stojković

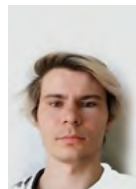

*bežične mreže osjetila; raspodjeljeni algoritmi*  
*wireless sensor networks; distributed algorithms*

## Diego Sušanj



*obrada slike; bežične mreže osjetila; ugradbeni sustavi*  
*image processing; wireless sensor networks; embedded systems*

## Ana Vranković



*vremensko-frekvencijska analiza signala; teorija informacija*  
*time-frequency signal analysis; information theory*

## STRUČNI SURADNIK | ASSOCIATE

## Domagoj Pinčić



*obrada slike, strojno učenje*  
*image processing, machine learning*

# nastava i znanost education and science

## KOLEGIJI NA PREDDIPLOMSKIM SVEUČILIŠNIM STUDIJIMA

| UNDERGRADUATE UNIVERSITY COURSES

- *Algoritmi i strukture podataka*
- *Baze podataka*
- *Digitalna logika*
- *Građa računala*
- *Natjecateljsko programiranje*
- *Operacijski sustavi*
- *Programiranje*
- *Programiranje I*
- *Programiranje II*
- *Programska podrška u inženjerstvu*
- *Programsko inženjerstvo*
- *Računalne vještine*
- *Računalne mreže*
- *Razvoj web aplikacija*
- *Ugradbeni računalni sustavi*
- *Uvod u objektno orijentirano programiranje*
- *Uvod u umjetnu inteligenciju*
- *Algorithms and Data Structures*
- *Database Systems*
- *Digital Logic*
- *Computer Architecture*
- *Competitive programming*
- *Operating Systems*
- *Programming*
- *Programming I*
- *Programming II*
- *Computer Software in Engineering*
- *Software Engineering*
- *Computing Skills*
- *Computer Networks*
- *Web Applications Development*
- *Embedded Systems*
- *Introduction to Object Oriented Programming*
- *Introduction to Artificial Intelligence*

## KOLEGIJI NA DIPLOMSKIM SVEUČILIŠNIM STUDIJIMA

| GRADUATE UNIVERSITY COURSES

- *Analiza računalnih i komunikacijskih sustava*
- *Bežične mreže osjetila*
- *Inženjerstvo kompleksnih programskih sustava*
- *Komunikacija čovjek-stroj*
- *Mikrovalno inženjerstvo*
- *Mobilna robotika*
- *Mobilne komunikacije*
- *Napredna korisnička sučelja*
- *Napredne računalne mreže*
- *Napredni algoritmi i strukture podataka*
- *Objektno orijentirano programiranje*
- *Programiranje ugradbenih sustava*
- *Programski određen radio*
- *Računalna obrada govora i jezika*
- *Razvoj mobilnih aplikacija*
- *Strojno učenje*
- *Teorija informacija i kodiranje*
- *Usluge zasnovane na lokaciji*
- *Computer and Communication System Analysis*
- *Wireless Sensor Networks*
- *Complex Software Systems Engineering*
- *Human-Machine Interaction*
- *Microwave Engineering*
- *Mobile Robotics*
- *Mobile Communications*
- *Advanced User Interfaces*
- *Advanced Computer Networks*
- *Advanced Algorithms and Data Structures*
- *Object Oriented Programming*
- *Embedded Systems Programming*
- *Software-Defined Radio*
- *Computer Speech and Language Processing*
- *Mobile Applications Development*
- *Machine Learning*
- *Information Theory and Coding*
- *Usluge zasnovane na lokaciji*

## KOLEGIJI NA PREDDIPLOMSKIM STRUČNIM STUDIJIMA

| UNDERGRADUATE VOCATIONAL COURSES

- *Informacije i komunikacije*
- *Primjena računala ST*
- *Računalne mreže ST*
- *Svjetlovodne mreže*
- *Telekomunikacijski uređaji i mreže*
- *Information and Communication*
- *Applied Computing ST*
- *Computer Networks ST*
- *Optical Networks*
- *Telecommunication Devices and Networks*

## ZNAJSTVENOISTRAŽIVAČKI RAD | SCIENTIFIC RESEARCH

- *bežične mreže osjetila, raspodijeljeni algoritmi*  
wireless sensor networks, distributed algorithms
- *računalna obrada govora i jezika, raspoznavanje uzoraka*  
speech processing and pattern recognition
- *nosive antene; pametna odjeća; rekonfigurabilni sklopovi*  
wearable antennas; smart clothing; reconfigurable circuits
- *mobilna robotika, blockchain, ugradbeni sustavi, satelitska navigacija*  
mobile robotics, blockchain, embedded systems, satellite navigation
- *digitalna obrada signala, teorija informacija, kodiranje, kriptografija, umjetna inteligencija*  
digital signal processing, information theory, coding, cryptography, artificial intelligence
- *interakcija čovjeka i računala, inženjerstvo upotrebljivosti, prediktivno modeliranje i vrednovanje, univerzalni pristup*  
human-computer interaction, usability engineering, predictive modeling and evaluation, universal access
- *primijenjeno meko računarstvo, dubinska analiza podataka, programsko inženjerstvo*  
applied soft computing, data mining, software engineering
- *strojno učenje, računalom potpomognuto dijagnosticiranje, analiza slike*  
machine learning, computer aided diagnosis, image analysis
- *digitalna obrada signala, adaptivni wavelet algoritmi*  
digital signal processing, adaptive wavelet algorithms
- *obrada slike, bežične mreže osjetila, ugradbeni sustavi*  
image processing, wireless sensor networks, embedded systems
- *vremensko-frekvencijska analiza signala, informacijske mjere*  
time-frequency signal analysis, information measures
- *interakcija čovjeka i računala; mobilne aplikacije*  
human-computer interaction (HCI); mobile applications
- *obrada slike, strojno učenje*  
image processing, machine learning
- *interakcija čovjeka i računala, digitalna obrada signala*  
human-computer interaction (HCI), digital signal processing
- *strojno učenje, računalom potpomognuto dijagnosticiranje*  
machine learning, computer aided diagnosis
- *neuroznanosti, digitalna obrada signala*  
neuroscience, digital signal processing
- *vremensko-frekvencijska analiza signala, informacijske mjere*  
time-frequency signal analysis, information measures

## PROJEKTI | PROJECTS

- *Razvoj pametne jakne, Sveučilište u Rijeci, znanstveno-istraživački. Voditelj projekta Joler.*  
Smart Jacket Development, Funded by: University of Rijeka, Croatia. Scientific research.  
Principal Investigator Joler
- *Prirodna i višemodalna komunikacija čovjek stroj. Znanstveni projekt financiran od strane Sveučilišta u Rijeci. Glavni istraživač Ipšić.*

*Natural and multimodal man machine communication. A scientific project funded by the University of Rijeka. Principal investigator Ipšić*

- *CEEPUS mreža "International Cooperation in Computer Science". Lokalni koordinator: J. Lerga.*  
CEEPUS network "International Cooperation in Computer Science". Local coordinator: J. Lerga
- *CEEPUS mreža CIII-AT-0042 "Image Processing, Information Engineering & Interdisciplinary Knowledge Exchange". Lokalni koordinator: I. Štajduhar*  
CEEPUS network CIII-AT-0042 "Image Processing, Information Engineering & Interdisciplinary Knowledge Exchange". Local coordinator: I. Štajduhar
- *DEcision Support System for green and safe ship Routing, Znanstveni projekt financiran od Hrvatske zaklade za znanost. Voditeljica: J. Prpić-Oršić. Suradnik: J. Lerga et al.*  
DEcision Support System for green and safe ship Routing, A scientific project funded by the Croatian Science Foundation. Principal investigator: J. Prpić-Oršić. Researchers: J. Lerga et al.
- *Computer-Aided Digital Analysis and Classification of Signals, Znanstveni projekt financiran od Sveučilišta u Rijeci. Voditelj projekta: J. Lerga. Suradnici: I. Štajduhar et al.*  
Computer-Aided Digital Analysis and Classification of Signals, A scientific project funded by the University of Rijeka. Principal investigator: J. Lerga. Researchers: I. Štajduhar et al.
- *Razvoj postupaka temeljenih na strojnom učenju za prepoznavanje bolesti i ozljeda iz medicinskih slika, Znanstveni projekt financiran od strane Sveučilišta u Rijeci, uniri-tehnic-18-15. Voditelj projekta: I. Štajduhar. Researchers: J. Lerga, S. Ljubić, D. Miletić, M. Milanić, S. Tschauner, T. Manojlović, F. Hrzić, A. Salkanović*  
Development of Machine-Learning-Based Techniques for Illness and Injury Detection in Medical Images, A scientific project funded by the University of Rijeka, uniri-tehnic-18-15. Principal investigator: I. Štajduhar. Researchers: J. Lerga, S. Ljubić, D. Miletić, M. Milanić, S. Tschauner, T. Manojlović, F. Hrzić, A. Salkanović
- *A Network for Gravitational Waves, Geophysics and Machine Learning, EU COST znanstveni projekt CA17137. Istraživači: J. Lerga, I. Štajduhar et al.*  
A Network for Gravitational Waves, Geophysics and Machine Learning, EU COST scientific project CA17137. Researchers: J. Lerga, I. Štajduhar et al
- *European Network for assuring food integrity using non-destructive spectral sensors, EU COST znanstveni projekt CA19145. Istraživači: I. Štajduhar, F. Hrzić et al.*  
European Network for assuring food integrity using non-destructive spectral sensors, EU COST scientific project CA19145. Researchers: I. Štajduhar, F. Hrzić et al
- *Ljubić, Vranković, Salkanović: Interaktivni tečaj za automatsko upravljanje, Erasmus+ Key Action 2: Cooperation for innovation and the exchange of good practices, 2018-1-SIO1-KA203-047081, 2018-2021, partner na projektu*  
Ljubić, Vranković, Salkanović: Interactive Course for Control Theory, Erasmus+ Key Action 2: Cooperation for innovation and the exchange of good practices, 2018-1-SIO1-KA203-047081, 2018-2021, project partner
- *Primjena strojnog učenja za pronalazak katalitički aktivnih peptida, UNIRI-plus projekt razvoja novog istraživačkog smjera, broj uniri-pr-tehnic-19-10, voditelj projekta: G. Mauša*  
Applying Machine Learning for the Discovery of Peptides with Catalytic Activity, UNIRI-plus project for new research directions, grant number uniri-pr-tehnic-19-10, principal investigator: G. Mauša
- *Povezivanje obrazovne i istraživačke zajednice za inovativno društvo osvješteno ograničenja resursa, projekt COST akcije Europske Kooperacije u Znanosti i Tehnologiji, broj CA19135, član upravnog odbora: G. Mauša*

Connecting education and research communities for an innovative resource aware society", COST action project funded by The European Cooperation in Science and Technology, grant no. CA19135, management committee member: G. Mauša

- **Dizajn katalitički aktivnih peptida i peptidnih nanostrukture, uspostavni istraživački projekt Hrvatske Zaklade za Znanost, broj UIP-2019-04-7999, Voditelj projekta: D. Kalafatović, istraživač: G. Mauša**  
Design of short catalytic peptides and peptide assemblies, scientific installation project funded by the Croatian Science Foundation, grant no. UIP-2019-04-7999, principal investigator: D. Kalafatović, researcher: G. Mauša
- **Računalni model strujanja, poplavlivanja i širenja onečišćenja u rijekama i obalnim morskim područjima, istraživački projekt Euroopskih strukturalnih i investicijskih fondova, broj KK.05.1.1.02.0017, voditelj: L. Kranjčević, istraživač: G. Mauša**  
A computational model of flow, flooding and pollution dispersion in rivers and coastal marine areas", applied research project funded by European structural and investment funds, grant no. KK.05.1.1.02.0017, principal investigator: L. Kranjčević, researcher: G. Mauša
- **Pouzdan i sigurni složeni programski sustavi: od empirijskih principa do teorijskih modela u vidu industrijskih primjena, istraživački projekt Hrvatske Zaklade za Znanost, broj IP-2019-04-4216, Voditelj projekta: T. Galinac Grbac, istraživač: G. Mauša**  
Reliable and Safe Complex Software Systems: From Empirical Principles to Theoretical Models in View of Industrial Applications, scientific project funded by the Croatian Science Foundation, grant no. IP-2019-04-4216, principal investigator: T. Galinac Grbac, researcher: G. Mauša
- **Dig IT - Izrada standarda zanimanja i standarda kvalifikacija u djelatnostima računarstva (UP.03.1.1.03.0061). Stručnjaci: I. Štajduhar, S. Ljubić, G. Mauša**  
Dig IT - Development of occupational standards and standard of qualifications in computer science (UP.03.1.1.03.0061). Experts: I. Štajduhar, S. Ljubić, G. Mauša
- **National Competence Centres in the Framework of EuroHPC (EUROCC), Euroopski Horizon 2020 projekt H2020-JTI-EuroHPC-2019-2. Suradnici: I. Štajduhar, G. Mauša, J. Lerga et al. National Competence Centres in the Framework of EuroHPC (EUROCC), European Horizon 2020 projekt H2020-JTI-EuroHPC-2019-2. Researchers: I. Štajduhar, G. Mauša, J. Lerga et al**
- **Analiza hiperspektralnih slika korištenjem strojnog učenja i adaptivnog filtriranja prilagođenog podacima, Bilateralni hrvatsko-slovenski projekt. Voditelj: J. Lerga. Suradnici: I. Štajduhar, F. Hrzić, L. Batistić**  
Hyperspectral Image Analysis Using Machine Learning and Adaptive Data-Driven Filtering, Bilateral Croatian-Slovenian project. Principal investigator: J. Lerga. Researchers: I. Štajduhar, F. Hrzić, L. Batistić
- **DATA-CROSS - Napredne metode i tehnologije u znanosti o podacima i kooperativnim sustavima, Poziv: Vrhunska istraživanja znanstvenih centara izvrsnosti, Referenca: KK.01.1.1.01.0009. Istraživači: K. Lenac, D. Pinčić**  
DATA-CROSS Advanced Methods and Technologies in Data Science and Cooperative Systems, Call: Top-level researches in Centres of Excellence, Reference: KK.01.1.1.01.0009. Researchers: K. Lenac, D. Pinčić
- **Ugradbeni sustavi za 3D percepciju, Referenca: uniri-tehnic-18-295. Voditelj: K. Lenac. Istraživači: M. Tomić, D. Sušan, L. Batistić, D. Pinčić, D. Špoljar**  
Embedded Systems for 3D perception". Reference: uniri-tehnic-18-295. Principal investigator: K. Lenac. Researchers: M. Tomić, D. Sušan, L. Batistić, D. Pinčić, D. Špoljar

## PUBLIKACIJE | PUBLICATIONS

## RADovi U ČASOPISIMA | JOURNAL PAPERS

- **Petrovska, B.; Zdravevski, E.; Lameski, P.; Corizzo, R.; Štajduhar, I.; Lerga, J. Deep Learning for Feature Extraction in Remote Sensing: A Case-Study of Aerial Scene Classification, Sensors, ISSN: 1424-8220, 20 (14) 1-22, 2020, inozemstvo**
- **Ignatoski, M.; Lerga, J.; Stanković, Lj.; Daković, M. Comparison of Entropy and Dictionary Based Text Compression in English, German, French, Italian, Czech, Hungarian, Finnish, and Croatian Mathematics, ISSN: 2227-7390, 8 (7), 1-14, 2020, inozemstvo**
- **Vranković, A.; Lerga, J.; Saulig, N. A Novel Approach to Extracting Useful Information From Noisy TFDs Using 2D Local Entropy Measures, EURASIP Journal on Advances in Signal Processing, ISSN: 1687-6180, 18, 1-19, 2020, inozemstvo**
- **Selimović, D.; Lerga, J.; Prpić-Oršić, J.; Kenji, S. Improving the Performance of Dynamic Ship Positioning Systems: A Review of Filtering and Estimation Techniques, Journal of Marine Science and Engineering, ISSN: 2077-1312, 8 (4), 1-282020, inozemstvo**
- **Kirinčić, V.; Lerga, J.; Saulig, N.; Franković, D. Improved Power System State Estimator with Preprocessing Based on the Modified Intersection of Confidence Intervals, Sustainable Energy, Grids and Networks, ISSN: 2352-4677, 21, 44105, 2020, inozemstvo**
- **Madhale Jadav, G.; Lerga, J.; Štajduhar, I. Adaptive Filtering and Analysis of EEG Signals in the Time-Frequency Domain Based on the Local Entropy, EURASIP Journal on Advances in Signal Processing, ISSN: 1687-6180, 18, 1-18, 2020, inozemstvo**
- **Skoki, A.; Ljubić, S.; Lerga, J.; Štajduhar, I. Automatic Music Transcription for Traditional Woodwind Instruments Sopele, Pattern Recognition Letters, ISSN: 0167-8655, 128, 340-347, 2019, inozemstvo**
- **Skoki, A.; Ljubić, S.; Lerga, J.; Štajduhar, I. Sopele music dataset, Data in Brief, ISSN: 2352-3409, 28, 104840: 1-5, 2020, inozemstvo**
- **Saulig, N.; Lerga, J.; Milanović, Ž.; Ioana, C. Extraction of Useful Information Content from Noisy Signals Based on Structural Affinity of Clustered TFDs' Coefficients IEEE Transactions on Signal Processing, ISSN: 1053-587X, 67 (12), 3154-3167, 2019, inozemstvo**
- **Kirinčić, V.; Čeperić, E.; Vlahinić, S.; Lerga, J. Support Vector Machine State Estimation Applied Artificial Intelligence, ISSN: 0883-9514, 33 (6), 517-530, 2019, inozemstvo**
- **Hrzić, F.; Štajduhar, I.; Tschauer, S.; Sorantin, E.; Lerga, J. Local-Entropy Based Approach for X-Ray Image Segmentation and Fracture Detection, Entropy, ISSN: 1099-4300, 21 (4), inozemstvo**
- **Lenac, K.; Sušan, D.; Ramakić, A.; Pinčić, D. Extending Appearance Based Gait Recognition with Depth Data Applied Sciences-Basel, ISSN 2076-3417, 9, 2019, inozemstvo**
- **Ramakić, A.; Sušan, D.; Lenac, K.; Bundalo, Z. Depth-Based Real-Time Gait Recognition Journal of Circuits Systems and Computers, ISSN: 0218-1266, 29, 2020, inozemstvo**
- **Kalafatovic, D.; Mauša, G.; Rešetar Maslov, D.; Giralt, E. Bottom-Up Design Approach for OBOC Peptide Libraries, Molecules, ISSN: 1420-3049, 25 (15), 1 - 15, 2020, inozemstvo**
- **Joler, M.; Berkarić, A.; Klen, V. Testing an Arduino-based Approach for Full-Duplex Voice Communication and Body-Parameter Sensing Electronics for Use with Smart Clothing International Journal of Antennas and Propagation, ISSN: 1687-5869, vol. 2019, Article ID 8598912, 8 pages (online), 2019, inozemstvo**
- **Vlahinić, S.; Batistić, L.; Jadav, G.M.; Vrankić, M. Brain Computer Interface Based Communicator for Persons in Locked-in State, Informatica, ISSN: 0868-4952, 30, 4; 17, 2019, inozemstvo**

- Joler, M.; Kolonić, A.; Boljkovac, M. A Wideband Circularly Polarized Jeans-Based Antenna at 2.45 GHz, *Open Journal of Antennas and Propagation*, ISSN Print: 2329-8421 // ISSN online: 2329-8413, 8 (1), 1-18, 2020, inozemstvo
- Xie, Y.; Raj, A. N. J.; Hu, Z.; Huang, S.; Fan, Z.; Joler, M. A Twofold Lookup Table Architecture for Efficient Approximation of Activation Functions, *IEEE Transactions on Very Large Scale Integration (VLSI) Systems*, Electronic ISSN: 1557-9999 // Print ISSN: 1063-8210, rani pristup: DOI: 10.1109/TVLSI.2020.3015391, 44136, 2020, inozemstvo
- Krsnik, I.; Glavaš, G.; Krsnik, M.; Miletić, D.; Štajduhar, I. Automatic Annotation of Narrative Radiology Reports, *Diagnostics*, EISSN 2075-4418, 10(4), 196: 1-15, 2020, inozemstvo
- Jozinović, D.; Lomax, A.; Štajduhar, I.; Michelini, A. Rapid prediction of earthquake ground shaking intensity using raw waveform data and a convolutional neural network, *Geophysical Journal International*, Online ISSN 1365-246X, 222 (2), 1379–1389, 2020, inozemstvo
- Peronja, I.; Lenac, K.; Glavinović, R. Blockchain technology in maritime industry, *Pomorstvo*, ISSN: 1332-0718, e-ISSN 1846-8438, 34 (1), 178-184, 2020, Rijeka, Hrvatska
- Balen, J.; Ljepic, S.; Lenac, K.; Mandzuka, S. Air Quality Monitoring Device for Vehicular Ad Hoc Networks: EnvioDev, *International Journal of Advanced Computer Science and Applications (IJACSA)*, ISSN: 2158-107X, 11 (5), 580-590, 2020, inozemstvo

## POZVANA PREDAVANJA | INVITED LECTURES

- Jonatan Lerga, *Computer-Aided Nonstationary Signal Processing Faculty of Informatics, Department of Programming Languages and Compilers, Eötvös Loránd University, 2019, Budimpešta, Mađarska*
- Jonatan Lerga, *Applications of Computer-Aided Signal Processing Department of Mathematics and Informatics, Faculty of Economics, J. Selye University, 2019, Komarno, Slovačka*
- Jonatan Lerga, *Local Entropy Measures with Applications in Biomedicine, 7th Conference on Information Theory and Complex Systems (TINKOS 2019), 2019, Beograd, Srbija*
- Ivan Štajduhar, *Everything you never wanted to know about machine learning, but were forced to find out, 28th Summer School on Image Processing, SSIP 2020, 2020, Szeged, Mađarska*
- Ivan Štajduhar, *BirdbrAln Genius, Riječki znanstveni mostovi, 2019, Rijeka, Hrvatska*
- Goran Mauša, *Artificial intelligence in data science, Department of Mathematics and Informatics, Faculty of Economics, J. Selye University, 2020, Komarno, Slovačka*
- Miroslav Joler, *Some Cases of Antenna Research for Modern Communications, Seminar Series for Masters students from universities in Bratislava, Slovakia, Vienna, Austria, and Brno, Czech Republic, 2019, Brno, Češka Republika*
- Miroslav Joler, *Overview of Some Antenna and Mobile Communication-minded Research at the University of Rijeka, Brno University of Technology, Faculty of Electrical Engineering and Communication Technologies, Department of Radio Electronics, 2019, Brno, Češka Republika*
- Kristijan Lenac, *Blockchain - basic concepts and applicability, Third IAB Workshop-DREAMS-Information management for U-space. 2019., 2019, Madrid, Španjolska*

## MEĐUNARODNI KONGRESI | INTERNATIONAL CONGRESSES

- Selimović, D.; Lerga, J.; Prpić-Oršić, J. *Dynamic Ship Positioning Using the Time-Frequency Distributions and Kalman Filtering, My First Conference 2019, 15-15, 2019, Rijeka, Hrvatska*
- Daković, M.; Ponjavić, M.; Stanković, I.; Lerga, J.; Ioana, C. *Time Frequency Analysis of Ionospheric Whistler Signals, 27th Telecommunications Forum - TELFOR 2019, ISBN: 978-1-7281-4790-1, 1-4, 2019, Beograd, Srbija*
- Saulig, N.; Lerga, J.; Baracska, Z.; Daković, M. *Adaptive Thresholding in Extracting Useful Information from Noisy Time-Frequency Distributions, 11th International Symposium on Image and Signal Processing and Analysis - ISPA 2019, ISBN: 978-1-7281-3140-5, 329-334, 2019, Dubrovnik, Hrvatska*
- Lerga, J.; Prpić-Oršić, J. *Introduction to Time-Frequency Analysis of Signals in Ship Guidance, Navigation and Control, International Conference on Advanced Computational Engineering and Experimenting - ACEX 2019, 21-21, 2019, Atena, Grčka*
- Hrovatić, A.; Kwon, K.; Sušan, D.; Peer, P.; Emeršič, Ž. *Generation of 2D ear dataset with annotated view angles as a basis for angle-aware ear recognition Proceedings of the 28th International Electrotechnical and Computer Science Conference, 2019, Portorož, Slovenija*
- Salkanović, A.; Štajduhar, I.; Ljubić, S. *Floating Hierarchical Menus for Swipe-Based Navigation on Touchscreen Mobile Devices, 22nd International Conference on Human-Computer Interaction (HCI 2020), ISBN: 978-3-030-49061-4, 509-522, 2020, Copenhagen, Danska*
- Mauša, G.; Galinac Grbac, T.; Brezočnik, L.; Podgorelec, V.; Heričko, M. *Software Metrics as Identifiers of Defect Occurrence Severity, 8th workshop on Software quality analysis, monitoring, improvement, and applications (SQAMIA 2019), ISSN: 1613-0073, 9:1 - 9:9, 2019, Ohrid, North Macedonia*
- Gradišnik, M.; Karakatić, S.; Beranić, T.; Heričko, M.; Mauša, G.; Galinac Grbac, T. *The Impact of Refactoring on Maintainability of Java Code: A Preliminary Review 8th workshop on Software Quality Analysis, Monitoring, Improvement, and Applications (SQAMIA 2019), ISSN: 1613-0073, 2:1 - 2:11, 2019, Ohrid, North Macedonia*
- Ilić, V.; Bertolini, A.; Bonsignorio, F.; Jozinović, D.; Bulik, T.; Štajduhar, I.; Secrieru, I.; Koley, S. *Ambient seismic noise suppression in COST action G2Net, EGU General Assembly, 2020, Beč, Austrija*
- Manojlović, T.; Ilić, D.; Miletić, D.; Štajduhar, I. *Using DICOM Tags for Clustering Medical Radiology Images into Visually Similar Groups 9th International Conference on Pattern Recognition Applications and Methods (ICPRAM), 510-517, 2020, Valletta, Malta*
- Spoljar, D.; Crnjarić-Zic, N.; Lenac, K.; Perinovic, V. *Characterisation Of Multipath-Caused Commercial-Grade GPS Positioning Error In Intelligent Transport Systems (ITS) Proceedings of 2019 International Symposium ELMAR, 27-30, 2019, Zadar, Hrvatska*
- Šimunić, S.; Lenac, K. *A blockchain application for validating a path traveled by a drone Proceedings of the 13th Annual RIN Baska GNSS Conference, 2019, Baška, Hrvatska*
- Spoljar, D.; Crnjarić-Zic, N.; Sikirica, N.; Lenac, K. *Statistical Analysis of Ionospheric Scintillation S4 Index Time-Series During Development of an Ionospheric Storm Proceedings of ISGNSS 2019, 2019*
- Špoljar, D.; Ivić, S.; Lenac, K. *Satellite-based Positioning Model as an Optimisation Problem Solution, Proceedings of the 13th Annual RIN Baska GNSS Conference, 2019, Baška, Hrvatska*

MEĐUNARODNA SURADNJA | INTERNATIONAL COLLABORATIONS

- *University of Trieste, Italija, Italy*
- *AIBS Lab S.r.l., Italija, Italy*
- *Faculty of Mathematics and Physics, University of Ljubljana, Slovenija, Slovenia*
- *University of Szeged, Institute of Informatics, Mađarska, Hungary*
- *Medical University of Graz, Austrija, Austria*
- *Faculty of electrical engineering, computing and informatics, University of Maribor, Slovenija, Slovenia*
- *Institute for research in biomedicine, Barcelona, Spain, Španjolska, Spain*
- *University of Maribor, Faculty of Electrical Engineering and Computer Science, Maribor, Slovenija, Slovenia*
- *University of Szeged, Institute of Informatics, Szeged, Hungary, Mađarska, Hungary*
- *Johannes Kepler University Linz, Institute of Signal Processing, Linz, Austria, Austrija, Austria*
- *University of Montenegro, Podgorica, Montenegro, Crna Gora, Montenegro*
- *Eötvös Loránd University, Faculty of Informatics, Budapest, Hungary, Mađarska, Hungary*
- *J. Selye University, Faculty of Economics, Komarno, Slovakia, Slovačka, Slovakia*
- *FH Joanneum, Graz, Austrija, Austria*
- *Brno University of Technology, Brno, Czech Republic, Republika Češka, Czech Republic*
- *Shantou University, Shantou, China, Kina, China*
- *Faculty of Computer and Information Science, University of Ljubljana, Slovenija, Slovenia*

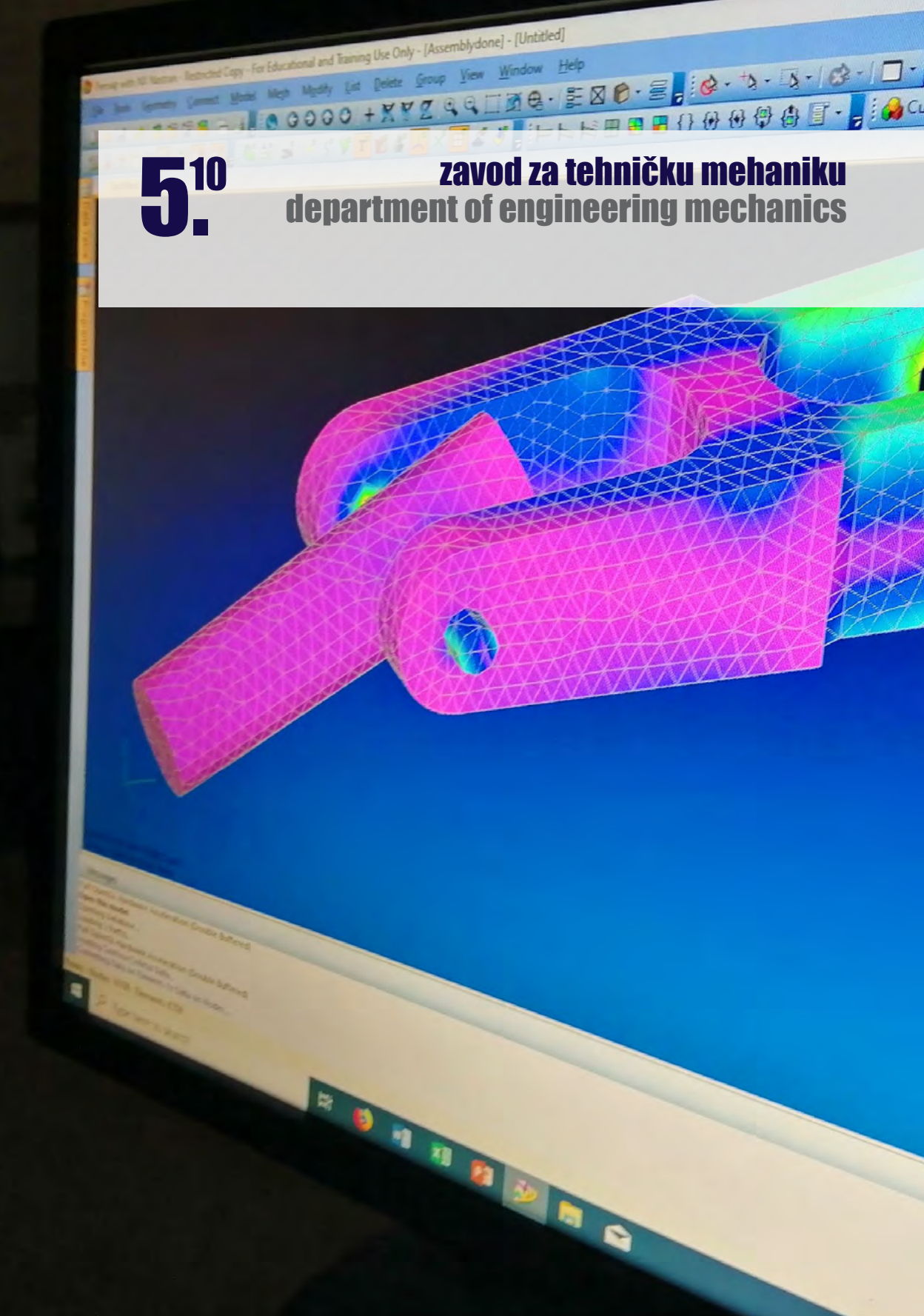

## djelatnici faculty and staff

### PREDSTOJNIK ZAVODA | DEPARTMENT HEAD:



Prof. dr. sc. / Prof. D. Sc. **Goran Turkalj**

*čvrstoća konstrukcija; nelinearna analiza konstrukcija; stabilnost konstrukcija; računarska analiza konstrukcija*  
*strength of materials; nonlinear structural analysis; structural stability; computational structural analysis*

### REDOVITI PROFESORI U TRAJNOM ZVANJU | TENURED PROFESSORS



**Marko Čanadija**

*termomehanika; eksperimentalna mehanika; statika; metoda konačnih elemenata; nanomehanika*  
*thermomechanics; experimental mechanics; statics; finite element method; nanomechanics*



**Roberto Žigulić**

*kinematika; dinamika; dinamika strojeva i robota; mehatronika; eksperimentalna mehanika*  
*kinematics; dynamics; dynamics of robots and machines; mechatronics; experimental mechanics*

### REDOVITI PROFESORI | PROFESSORS



**Sanjin Braut**

*kinematika; dinamika; vibracije; eksperimentalna mehanika; trajnost strojeva i konstrukcija; dinamika rotora*  
*kinematics; dynamics; vibration; experimental mechanics; durability of machines and structures; rotordynamics*



**Domagoj Lanc**

*čvrstoća; elasto-plastomehanika; stabilnost konstrukcija; kompozitne konstrukcije*  
*strength of materials; elasto-plastomechanics; structural stability; composite structures*

### IZVANREDNI PROFESOR | ASSOCIATE PROFESSOR

**Marino Brčić**

*statika; čvrstoća konstrukcija; mehanika i elementi konstrukcija; laboratorijske vježbe; eksperimentalna ispitivanja u mehanici konstrukcija i strojeva; metoda konačnih elemenata; nanomehanika*  
*statics; strength of materials; mechanics and structural elements; experimental methods in mechanics; finite element method; nanomechanics*



### DOCENTI | ASSISTANT PROFESSORS

**Sanjin Krščanski**

*statika; čvrstoća konstrukcija; mehanika i elementi konstrukcija; trajnost strojeva i konstrukcija; zamor; mehanika loma*  
*statics; strength of materials; mechanics and structural elements; durability of machines and structures; fatigue; fracture mechanics*



**Ante Skoblar**

*kinematika; dinamika; vibracije; akustika*  
*kinematics; dynamics; vibration; acoustics*



**Goranka Štimac Rončević**

*kinematika; dinamika; regulacija; aktivni magnetski ležajevi*  
*kinematics; dynamics; control; active magnetic bearings*



### ASISTENTI | ASSISTANTS

**Damjan Banić**

*čvrstoća konstrukcija; stabilnost konstrukcija; kompozitne konstrukcije; laboratorijske vježbe*  
*strength of materials; structural stability; composite structures; laboratory exercises*



**Sandra Kvaternik**

*čvrstoća konstrukcija; stabilnost konstrukcija; kompozitne konstrukcije; laboratorijske vježbe*  
*strength of materials; structural stability; composite structures; laboratory exercises*



**Martin Zlatić**

*statika; čvrstoća konstrukcija; laboratorijske vježbe*  
*statics; strength of materials; laboratory exercises*





## PROFESOR EMERITUS | PROFESSOR EMERITUS



Josip Brnić

*teorija elastičnosti i plastičnosti; metoda konačnih elemenata; eksperimentalna mehanika; optimizacija konstrukcija; mehanika grešaka i loma*  
*theory of elasticity and plasticity; finite element analysis; experimental mechanics; optimization of structure; fracture mechanics*

## VANJSKI SURADNICI | ASSOCIATES

## Igor Pešić

Sveučilište u Rijeci, Odsjek za politehniku  
 | University of Rijeka, Department of Polytechnics

*statika; čvrstoća konstrukcija*  
*statics; strength of materials*

## Franc Kosel

Fakulteta za Strojništvo, Univerza v Ljubljani, Ljubljana, Slovenija  
 | Faculty of Mechanical Engineering, University of Ljubljana, Ljubljana, Slovenia

*tehnička mehanika; čvrstoća; elasto-plastomehanika*

*engineering mechanics; strength of materials; elasto-plastomechanics*

## Neven Munjas

Istarsko veleučilište  
 | Istrian University

*statika; čvrstoća konstrukcija; mehanika i elementi konstrukcija*

*statics; strength of materials; mechanics and structural elements*

## Stojan Kravanja

Fakulteta za gradbeništvo, Univerza v Mariboru, Maribor, Slovenija  
 | Faculty of Civil Engineering, University of Maribor, Maribor, Slovenia

*tehnička mehanika; optimizacija konstrukcija*  
*engineering mechanics; structural optimization*

## nastava i znanost education and science

Nastava se izvodi iz područja primijenjene mehanike što uključuje analitičku, računalnu i eksperimentalnu mehaniku. Prema sadržaju razmatranja ovdje spadaju: statika, čvrstoća konstrukcija, stabilnost konstrukcija, mehanika konstrukcija, optimizacija konstrukcija, konačnoelementna analiza, tankostijene konstrukcije, računalna analiza konstrukcija, kompozitne konstrukcije, eksperimentalna ispitivanja u mehanici konstrukcija i strojeva, termomehanika, kontaktna mehanika, kinematika, dinamika, vibracije; akustika, regulacija i upravljanje dinamičkim sustavima; trajnost strojeva i konstrukcija; mehatronika, i.t.d.

Courses are running in the field of applied mechanics and includes analytical, computational and experimental mechanics. According to the content of consideration, here belong: statics, strength of materials, structural stability, structural mechanics, optimization of structures, finite element analysis, thin-walled structures, computational analysis of structures, composite structures, experimental testing of structures and machines, thermomechanics, contact mechanics, kinematics, dynamics, vibrations, vibroacoustics, dynamic system control, durability of machines and structures; mechatronics, etc.

## KOLEGIJI NA PREDDIPLOMSKIM SVEUČILIŠNIM STUDIJIMA

| UNDERGRADUATE UNIVERSITY COURSES

- |   |   |
|---|---|
| • Statika                                   | • Statics                                     |
| • Čvrstoća konstrukcija I                   | • Strength of Materials I                     |
| • Osnove primjene metode konačnih elemenata | • Introduction to Finite Element Method (FEM) |
| • Čvrstoća konstrukcija                     | • Strength of Materials                       |
| • Računarska analiza konstrukcija           | • Computational Structural Analysis           |

- *Mehanika i elementi konstrukcija*
- *Kinematika*
- *Dinamika*

- *Mechanics and Structural Elements*
- *Kinematics*
- *Dynamics*

## KOLEGIJI NA DIPLOMSKIM SVEUČILIŠNIM STUDIJIMA

| GRADUATE UNIVERSITY COURSES

- |  |  |
|--|--|
| • Čvrstoća konstrukcija II                                       | • Strength of Materials II                                     |
| • Metoda konačnih elemenata čvrstih tijela                       | • Finite Element Method of Solids                              |
| • Optimalni dizajn konstrukcija                                  | • Optimization of Structures                                   |
| • Eksperimentalna ispitivanja u mehanici konstrukcija i strojeva | • Experimental Testing in Mechanics of Structures and Machines |
| • Termomehanika  | • Thermomechanics  |
| • Stabilnost konstrukcija  | • Stability of Structures                                      |
| • Teorija strojeva i mehanizama                                  | • Theory of machines and mechanisms                            |
| • Eksperimentalna ispitivanja u mehanici konstrukcija i strojeva | • Experimental Testing in Mechanics of Structures and Machines |
| • Regulacija i upravljanje dinamičkim sustavima                  | • Dynamic Systems Control                                      |
| • Trajnost strojeva i konstrukcija                               | • Durability of Machines and Structures                        |
| • Vibracije  | • Vibration  |
| • Mehanika kompozita   | • Mechanics of Composites                                      |

## KOLEGIJI NA PREDDIPLOMSKIM STRUČNIM STUDIJIMA

| UNDERGRADUATE VOCATIONAL COURSES

- |  |   |
|--|---|
| • <i>Mehanika I</i>                          | • <i>Mechanics I</i>                          |
| • <i>Mehanika i elementi konstrukcija ST</i> | • <i>Mechanics and Structural Elements ST</i> |
| • <i>Čvrstoća</i>                            | • <i>Strength of Materials</i>                |
| • <i>Mehanika II</i>                         | • <i>Mechanics II</i>                         |

## KOLEGIJI NA POSLIJEDIPLOMSKIM SVEUČILIŠNIM (DOKTORSKIM) STUDIJIMA

| POSTGRADUATE UNIVERSITY (DOCTORAL) COURSES

- |   |   |
|---|---|
| • <i>Elastomehanika i plastomehanika</i>              | • <i>Elastomechanics and Plastomechanics</i>                  |
| • <i>MKE i optimizacija konstrukcija</i>              | • <i>FEM and Optimization of Structures</i>                   |
| • <i>IP iz termomehanike</i>                          | • <i>Advanced Thermomechanics</i>                             |
| • <i>Nanomehanika</i>                                 | • <i>Nanomechanics</i>  |
| • <i>Nelinearna analiza konstrukcija</i>              | • <i>Nonlinear Structural Analysis</i>                        |
| • <i>Računarska analiza stabilnost konstrukcija</i>   | • <i>Computational Structural Stability Analysis</i>          |
| • <i>Vibracije i trajnost strojeva i konstrukcija</i> | • <i>Vibrations and Durability of Machines and Structures</i> |
| • <i>Dinamika nelinearnih mehaničkih sustava</i>      | • <i>Dynamics of nonlinear mechanical systems</i>             |
| • <i>Zaštita od buke i vibracija</i>                  | • <i>Protection against Noise and Vibration</i>               |
| • <i>Viskoelastičnost i viskoplastičnost</i>          | • <i>Viscoelasticity and Viscoplasticity</i>                  |

## ZNASTVENOISTRAŽIVAČKI RAD | SCIENTIFIC RESEARCH

- *Primijenjena mehanika: računalna mehanika, eksperimentalna mehanika, mehanika grešaka i loma konstrukcija, optimalni dizajn konstrukcija, stabilnost konstrukcija, vibracije, vibroakustika, dinamika strojeva i konstrukcija, dinamika rotora, mehatronika, termomehanika, nanomehanika, integritet konstrukcija*

*Applied mechanics: computational mechanics, experimental mechanics, failure and fracture mechanics of structures, optimal structural design, structural stability, vibrations, vibroacoustics, dynamics of structures and machines, rotor dynamics, mechatronics, thermomechanics, nanomechanics, structural integrity.*

## PROJEKTI | PROJECTS

- *Istraživanje, analiza i modeliranje ponašanja konstrukcijskih elemenata opterećenih pri sobnoj i povišenim temperaturama, Sveučilište u Rijeci, uniri-technic-18-42, Josip Brnić.*

*Investigation, analysis and modeling the behavior of structural elements stressed at room temperature and high temperatures, University of Rijeka, uniri-technic-18-42, Josip Brnić*

- *Numeričko modeliranje FG kompozitnih konstrukcija grednog tipa, Sveučilište u Rijeci, uniri-technic-18-139, Domagoj Lanc*  
*Numerical modeling of FG composite beam-type structures, University of Rijeka, uniri-technic-18-139, Domagoj Lanc*
- *Konačnoelementni modeli za analizu nelinearnog odziva tankostjenih grednih konstrukcija, Sveučilište u Rijeci, uniri-technic-18-107, Goran Turkalj*  
*Finite element models for nonlinear analysis of thin-walled beam-type structure, University of Rijeka, uniri-technic-18-107, Goran Turkalj*
- *Nelinearno dinamičko ponašanje rotacijskih strojeva, uniri-tehnic-18-225, Sveučilište u Rijeci, Sanjin Braut, od 2019.*  
*Nonlinear dynamic behavior of rotating machines, uniri-tehnic-18-225, University of Rijeka, Sanjin Braut, since 2019.*
- *Procjena granične nosivosti inženjerskih konstrukcija, LOCAPES, IP-2019-04-8615, HRZZ, Domagoj Lanc*  
*Estimation of limit load capacity of engineering structures, LOCAPES, IP-2019-04-8615, HRZZ, Domagoj Lanc*
- *Nelokalni mehanički modeli nanogreda, IP-2019-04-4703. Hrvatska zaklada za znanost, Marko Čanađija, od 2020.*  
*Nonlocal mechanical models of nanobeams, IP-2019-04-4703, Croatian Science Foundation, Marko Čanađija, since 2020.*
- *Mehaničko ponašanje nanostruktura, uniri-tehnic-18-37 Sveučilište u Rijeci, Marko Čanađija, od 2019.*  
*Mechanical behavior of nanostructures, uniri-tehnic-18-37, University of Rijeka, Marko Čanađija, since 2019.*

#### PUBLIKACIJE | PUBLICATIONS

#### RADOVI U ČASOPISIMA | JOURNAL PAPERS

- *Kršćanski, S.; Brnić, J. Prediction of Fatigue Crack Growth in Metallic Specimens under Constant Amplitude Loading Using Virtual Crack Closure and Forman Model, Metals, 2075-4701 10, 7;977, 14, 2020*
- *Gao, Z.; Ba, X.; Yang, H.; Yin, C.; Liu, S.; Niu, J.; Brnić, J. Joining of Silicon Particle-Reinforced Aluminum Matrix Composites to Kovar Alloys Using Active Melt-Spun Ribbons in Vacuum Conditions, Materials, 1996-1944, 13, 2965, 2020*
- *Brnić, J.; Krščanski, S.; Brčić, M. Mechanical Behavior Analysis of Stainless Steels Subjected to Uniaxial Stress Tests, Materials science and engineering, 1757-8981, 840, 1; 012012, 6, 2020*
- *Gao, Z.; Yang, H.; Feng, J.; Ji, F.; Niu, J.; Brnić, J. Flux-Free Diffusion Joining of SiCp/6063 Al Matrix Composites Using Liquid Gallium with NanoCopper Particles in Atmosphere Environment Nanomaterials, 2079-4991, 10, 437-449, 2020*
- *Brnić, J.; Krščanski, S.; Brčić, M.; Geng, L.; Niu, J.; Ding, B. Reliable experimental data as a key factor for design of mechanical structures, Structural Engineering and Mechanics, 1225-4568 72, 245-256, 2019*
- *Randić, M.; Pavletić, D.; Turkalj, G. Multiparametric Investigation of Welding Techniques on Toe Radius of High Strength Steel at Low- Temperature Levels Using 3D-Scanning Techniques Metals, 2075-4701, 9, 1355, 2019*

- *Kvaternik, S.; Filippi, M.; Lanc, D.; Turkalj, G.; Carrera, E. Comparison of classical and refined beam models applied on isotropic and FG thin-walled beams in nonlinear buckling response Composite Structures, 0263-8223, 229, 111490, 2019*
- *Barretta, R.; Čanađija, M.; Marotti de Sciarra, F. On Thermomechanics on Multilayered Beams International Journal of Engineering Science, 0020-7225, 155, 103364, 2020*
- *Barretta, R.; Čanađija, M.; Marotti de Sciarra, F. Nonlocal Mechanical Behavior of Layered Nanobeams, Symmetry, 2073-8994, 12, 717, 2020*
- *Brnić, J.; Brčić, M.; Krščanski, S.; Čanađija, M.; Niu, J. Analysis of Materials of Similar Mechanical Behavior and Similar Industrial Assignment Procedia Manufacturing, doi:10.1016/j.promfg.2019.12.037, 37, 207-213, 2019*
- *Brčić, M.; Brnić, J.; Čanađija, M. Equivalent beam model of SWNT and DWNT with imperfections, Procedia Manufacturing, doi:10.1016/j.promfg.2019.12.068, 37, 417-424, 2019*
- *Braut, S.; Pavlović, A.; Beno, P.; Babic, M. Measuring Strain in Sheet Metals, FME TRANSACTIONS, 1451-2092, 47, 477-486, 2019*
- *Braut, S.; Žigulić, R.; Skoblar, A.; Štimac Rončević, G. Partial Rub Detection Based on Instantaneous Angular Speed Measurement and Variational Mode Decomposition, Journal of Vibration Engineering & Technologies, 2321-3558, 8, 351-364, 2020*
- *Piličić, S.; Kegalj, I.; Tserga, E.; Milošević, T.; Žigulić, R.; Skoblar, A.; Traven, L. Influence of meteorological conditions on noise dispersion in the Port of Thessaloniki, Noise Mapping doi:10.1515/noise-2020-0012, 7, 135-145, 2020*
- *Piličić, S.; Traven, L.; Milošević, T.; Kegalj, I.; Skoblar, A.; Žigulić, R. Noise Pollution – Introduction to the State of the Research and the Implementation in the Horizon 2020 Project Pixel, Journal of Maritime & Transportation Sciences, 0554-6397, 3, 133-145 2020*
- *Cazin, D.; Braut, S.; Božić, Ž.; Žigulić, R. Low cycle fatigue life prediction of the demining tiller tool, Engineering failure analysis, 1350-6307, 111, 2020*
- *Muminović, A.; Braut, S.; Muminović, A.; Šarić, I.; Štimac Rončević, G. Improvement of flexible rotor/active magnetic bearings system performance using PI-D control, Engineering review 1330-9587, 40, 112-123, 2020*

#### POZVANA PREDAVANJA | INVITED LECTURES

- *Sanjin Braut, Marina Tevčić, Mirko Butković, Željko Božić, Roberto Žigulić, Locati method in fatigue strength testing of turbo machine blades, 4th International Conference on Structural Integrity and Durability, 2020, Dubrovnik, Hrvatska*

#### MEĐUNARODNI KONGRESI | INTERNATIONAL CONGRESSES

- *Banić, D.; Turkalj, G.; Lanc, D.; Kvaternik, S. Shear deformable beam model for stability analysis of beam type structures with composite cross sections, MECHCOMP 2019, 5th International Conference on Mechanics of Composites, 30, 2019, Lisabon, Portugal*
- *Kvaternik, S.; Lanc, D.; Turkalj, G.; Banić, D. Beam model for thermal buckling analysis of thin-walled functionally graded open section beams, MECHCOMP 2019, 5th International Conference on Mechanics of Composites, 135, 2020, Lisabon, Portugal*
- *Lanc, D.; Turkalj, G.; Krščanski, S. Behaviour of axially loaded FG column in creep regime, MECHCOMP 2019, 5th International Conference on Mechanics of Composites, 135, 2020, Lisabon, Portugal*

- Brnić, J.; Brčić, M.; Krščanski, S. *Considerations relating to the behavior of steel alloys of similar industrial applications, The 9th International Conference on Physical and Numerical Simulation of Materials Processing (9th ICPNS), 2019, Moskva/St. Petersburg, Rusija*
- Piličić, S.; Traven, L.; Milošević, T.; Kegalj, I.; Skoblar, A.; Žigulić, R. *Noise Pollution – Introduction to the State of the Research and the Implementation in the Horizon 2020 Project PIXEL, 8th International Conference on Marine Technology – WINKLER 2019, 1-2, 2019 Rijeka, Hrvatska*
- Braut, S.; Sikanen, E.; Nerg, J.; Sopanen, J.; Božić, Ž. *Fatigue Life Prediction of Electric Raceabout (ERA) Traction Motor Rotor, 4th International Conference on Structural Integrity and Durability, 1, 2020, Zagreb, Hrvatska*

#### MEĐUNARODNA SURADNJA | INTERNATIONAL COLLABORATIONS

- *Civil Engineering Faculty, University of Maribor, Slovenija, Slovenia*
- *Institute of Mechanics Department of Mechanical Engineering TU Dortmund, Njemačka, Germany*
- *School of Materials Science and Engineering, Henan Polytechnic University, Kina, China*
- *Harbin Institute of Technology, School of Materials Science and Engineering, Kina, China*
- *University of Bologna, Italija, Italia*
- *Faculty of Engineering - University of Kragujevac, Srbija, Serbia*
- *Faculty of Mechanical Engineering - University of Montenegro, Crna Gora, Montenegro*
- *Faculty of Mechanical Engineering, University of Ljubljana, Slovenija, Slovenia*
- *Institute of Materials and Welding, Graz University of Technology, Austrija, Austria*
- *Faculty of Engineering and Environment, Northumbria University, Newcastle upon Tyne, Velika Britanija, United Kingdom*
- *L'Università degli Studi di Napoli Federico II, Naples, Italija, Italy*
- *Lappeenranta University of Technology, Finska, Finland*
- *Dipartimento di Ingegneria Meccanica e Aerospaziale, Politecnico di Torino, Italija, Italy*
- *La Trobe University, Department of Civil Engineering and Physical Sciences, Melbourne, Australija, Australia*
- *Faculty of Mechanical Engineering, University of Sarajevo, BiH, Bosnia and Herzegovina*
- *Dipartimento di Meccanica, Politecnico di Milano, Italija, Italy*

5<sup>11</sup>

**zavod za termodinamiku i energetiku**  
**department of thermodynamics and**  
**energy engineering**

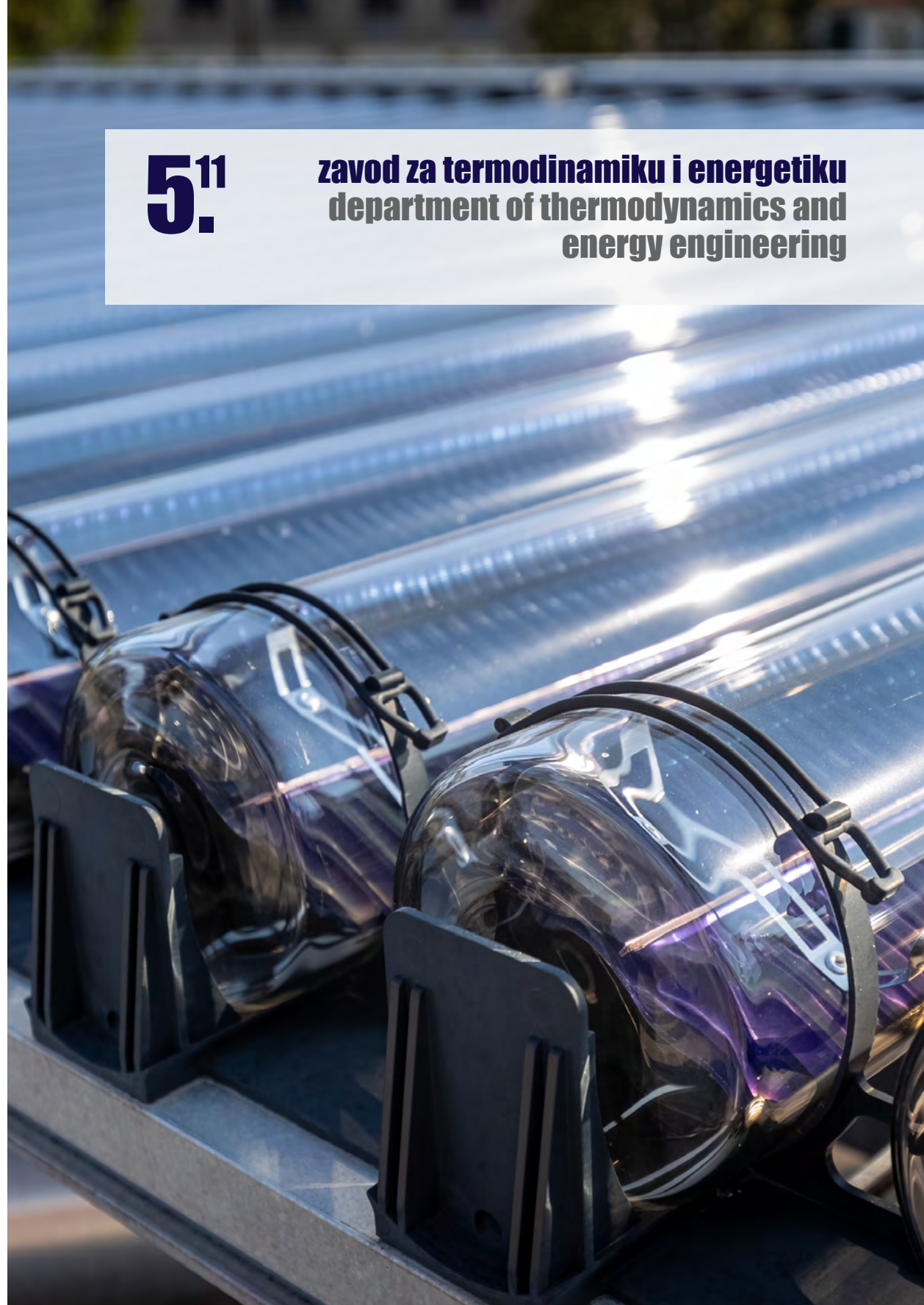



## djelatnici faculty and staff

### PREDSTOJNIK ZAVODA | DEPARTMENT HEAD:



Prof. dr. sc. / Prof. D. Sc. **Branimir Pavković**

*tehnika hlađenja; kompresori; procesna oprema; dizalice topline; energetska učinkovitost; obnovljivi izvori energije*  
refrigeration; compressors; process equipment; heat pumps; energy efficiency; renewable energy sources

### REDOVITI PROFESORI U TRAJNOM ZVANJU | TENURED PROFESSORS



**Tomislav Mrakovčić**

*brodski energetske sustavi; brodski pogonski sustavi; brodski pomoćni strojevi; numeričko modeliranje prijenosa topline i tvari*  
marine energy systems; marine propulsion systems; marine auxiliary machinery; numerical modeling of heat and mass transfer



**Anica Trp**

*termodinamika; izmjenivači topline; numeričko modeliranje prijenosa topline i tvari; obnovljivi izvori energije*  
thermodynamics; heat exchangers; numerical modeling of heat and mass transfer; renewable energy sources

### REDOVITI PROFESOR | PROFESSOR



**Kristian Lenić**

*termodinamika; izmjenivači topline; numeričko modeliranje prijenosa topline i tvari; obnovljivi izvori energije*  
thermodynamics; heat exchangers; numerical modeling of heat and mass transfer; renewable energy sources

### IZVANREDNI PROFESORI | ASSOCIATE PROFESSORS



**Tomislav Senčić**

*toplinski strojevi i uređaji; goriva, maziva i voda*  
thermal machines; fuels, lubricants and water

**Igor Wolf**



*tehnika grijanja; sustavi ventilacije i klimatizacije; obnovljivi izvori energije; središnji nadzorni i upravljački sustavi; energetska učinkovitost; mjerenja u termotehnici*  
hvac systems; renewable energy sources; central management and control systems; energy efficiency; thermal measurements

### DOCENTI | ASSISTANT PROFESSORS

**Paolo Blecich**



*termodinamika; numeričko modeliranje prijelaza topline i izmjene tvari; obnovljivi izvori energije*  
thermodynamics; numerical modelling of heat and mass transfer; renewable energy sources

**Igor Bonefačić**



*termodinamika; numeričko modeliranje procesa izgaranja, prijenosa topline i tvari; obnovljivi izvori energije*  
thermodynamics; numerical modelling of combustion, heat and mass transfer; renewable energy sources

**Ozren Bukovac**



*motori s unutrašnjim izgaranjem; termodinamika; toplinski strojevi; numeričko modeliranje; neuronske mreže*  
internal combustion engines; thermodynamics; heat engines; numerical modeling; neural networks

**Boris Delač**



*tehnika hlađenja; mjerenja u termotehnici; kompresori; procesna oprema; dizalice topline*  
refrigeration; thermal measurements; compressors; process equipment; heat pumps

**Viktor Dragičević**



*energetski sustavi; energetske i procesne uređaje; inženjerstvo zaštite okoliša*  
energy systems; energy and process facilities; environmental engineering

**Vladimir Glažar**



*termodinamika; izmjenivači topline; numeričko modeliranje prijenosa topline i tvari; energetska postrojenja; inženjerska vizualizacija*  
thermodynamics; heat exchangers; numerical modeling of heat and mass transfer; energy plants; engineering visualization

**Vedran Mrzljak**

*motori s unutarnjim izgaranjem; termodinamika; toplinski strojevi; toplinske turbine; energetska postrojenja; numeričko modeliranje*  
*internal combustion engines; thermodynamics; heat engines; heat turbines; energy plants; numerical modeling*

**ASISTENTI | ASSISTANTS****Josip Batista**

*termodinamika; izmjenjivači topline; numeričko modeliranje prijenosa topline i tvari; obnovljivi izvori energije*  
*thermodynamics; heat exchangers; numerical modeling of heat and mass transfer; renewable energy sources*

**Mateo Kirinčić**

*termodinamika; izmjenjivači topline; numeričko modeliranje prijenosa topline i tvari; obnovljivi izvori energije*  
*thermodynamics; heat exchangers; numerical modeling of heat and mass transfer; renewable energy sources*

**Vedran Medica - Viola**

*numeričko modeliranje i simulacije toplinskih sustava; brodski sustavi; motor s unutarnjim izgaranjem; toplinske turbine; tehnika hlađenja*  
*numerical modelling and simulation of thermal systems; marine systems; internal combustion engines; heat turbines; refrigeration*

**Fran Torbarina**

*termodinamika; izmjenjivači topline; numeričko modeliranje prijenosa topline i tvari; obnovljivi izvori energije*  
*thermodynamics; heat exchangers; numerical modeling of heat and mass transfer; renewable energy sources*

**PROFESOR EMERITUS | PROFESSOR EMERITUS****Špiro Milošević**

## nastava i znanost education and science

*Nastava iz područja znanstvenih polja strojarstva, temeljnih i interdisciplinarnih tehničkih znanosti, znanstvenih grana procesnog energetskeg strojarstva, brodskog strojarstva, termodinamike, energetike i inženjerstva okoliša, Energetski sistemi; Energetska postrojenja; Energetska oprema, uređaji i strojevi; Zaštita okoliša; Procesno inženjerstvo.*

**CO:** 1. Program stručnog osposobljavanja osoba koje provode energetske preglede i/ili energetske certificiranje zgrada s jednostavnim tehničkim sustavom (Modul 1)  
 2. Program stručnog osposobljavanja osoba koje provode energetske preglede i/ili energetske certificiranje zgrada sa složenim tehničkim sustavom (Modul 2)  
 3. Program izobrazbe osoba koje provode energetske preglede za velika poduzeća

*Lectures in the field of scientific fields of Mechanical Engineering, Fundamental and Interdisciplinary Engineering Sciences, the scientific branches of Process Energy Engineering, Marine Engineering, Thermodynamics, Energy Engineering and Environmental Engineering, Energy systems; Power plants; Energy equipment, facilities and engines; Environmental protection, Process engineering.*

**CO:** 1. Education of persons who are to perform energy audits and/or energy certification of buildings with a simple technical system (Module 1)  
 2. Education of persons who are to perform energy audits and/or energy certification of buildings with a complex technical system (Module 2)  
 3. Education program for persons who are to perform energy audits of big enterprises

**KOLEGIJI NA PREDDIPLOMSKIM SVEUČILIŠNIM STUDIJIMA**

| UNDERGRADUATE UNIVERSITY COURSES

- *Toplinski strojevi i uređaji*
- *Izvori energije*
- *Termodinamika I*
- *Termodinamika BG*
- *Termodinamika i energetika*
- *Energetski sustavi*
- *Tehnika grijanja*
- *Brodski pomoćni strojevi*
- *Thermal machine and devices*
- *Energy Sources*
- *Thermodynamics I*
- *Thermodynamics NA*
- *Thermodynamics and Energy Engineering*
- *Energy systems*
- *Heating Systems*
- *Marine Auxiliary Machinery*

**KOLEGIJI NA DIPLOMSKIM SVEUČILIŠNIM STUDIJIMA**

| GRADUATE UNIVERSITY COURSES

- *Goriva, maziva i voda*
- *Termodinamika II*
- *Numeričko modeliranje u termodinamici*
- *Plinska tehnika*
- *Tehnički izmjenjivači topline*
- *Termodinamika smjesa*
- *Energetski i procesni uređaji*
- *Termoenergetska postrojenja*
- *Energetska postrojenja*
- *Inženjerstvo zaštite okoliša*
- *Procesno inženjerstvo*
- *Tehnika klimatizacije i automatska regulacija*
- *Brodski termotehnički sustavi*
- *Obnovljivi izvori energije*
- *Toplinska mjerenja*
- *Fuels, lubricants and water*
- *Thermodynamics II*
- *Numerical Modelling in Thermodynamics*
- *Gas Engineering*
- *Heat Exchangers*
- *Thermodynamics of Mixtures*
- *Energy and process facilities*
- *Thermal power plants*
- *Power plants*
- *Environmental engineering*
- *Process engineering*
- *Air Conditioning and Automation Systems*
- *Marine HVAC&R Systems*
- *Renewable Energy Sources*
- *Thermal Measurements*

- Brodski energetski uređaji
- Brodski sustavi
- Toplinske turbine
- Kompresori
- Tehnika hlađenja
- Laboratorijske vježbe u termotehnici
- Oprema procesnih postrojenja
- Računalno modeliranje sustava u termotehnici i termoenergetici
- Ship Energy Facilities
- Ship Systems
- Heat turbines
- Compressors
- Refrigeration
- Laboratory Practice in Thermal Engineering
- Process Plants Equipment
- Računalno modeliranje sustava u termotehnici i termoenergetici

**KOLEGIJI NA PREDDIPLOMSKIM STRUČNIM STUDIJIMA**

| UNDERGRADUATE VOCATIONAL COURSES

- Toplinski strojevi i uređaji 2
- Toplina
- Energetika u procesnoj industriji
- Zaštita okoliša i radne sredine
- Tehnološki procesi u procesnoj industriji
- Grijanje i klimatizacija
- Brodski sustavi, pomoćni strojevi i uređaji
- Toplinski strojevi i uređaji 1
- Thermal machines and devices 2
- Thermodynamics
- Energetics in process industry
- Environmental and working space protection
- Technological processes in process industry
- Heating and Air-Conditioning Systems
- Ship Systems and Auxiliaries
- Thermal machines and devices 1

**KOLEGIJI NA POSLIJEDIPLOMSKIM SVEUČILIŠNIM (DOKTORSKIM) STUDIJIMA**

| POSTGRADUATE UNIVERSITY (DOCTORAL) COURSES)

- Eksperimentalne metode u toplinskoj tehnici i termoenergetici
- Izabrana poglavlja iz toplinskih znanosti
- Izabrana poglavlja iz izmjenjivača topline
- Numeričko modeliranje prijelaza topline
- Termodinamička analiza procesa
- Termodinamika smjesa i toplinski uređaji
- Izabrana poglavlja iz grijanja i klimatizacije
- Obnovljivi izvori energije
- Izabrana poglavlja iz brodskih energetskih postrojenja
- Izabrana poglavlja iz brodskih strojnih kompleksa
- Izabrana poglavlja iz tehnike hlađenja i tehnike niskih temperatura
- Zaštita okoliša u tehnici hlađenja
- Experimental Methods in Thermal and Power Engineering
- Selected Topics on Thermal Sciences
- Selected Topics on Heat Exchangers
- Numerical Modeling of Heat Transfer
- Thermodynamic Analysis of Processes
- Thermodynamics of Mixtures and Thermal Devices
- Selected Topics on Heating and Air-Conditioning
- Renewable Energy Sources
- Selected Topics Marine Energy Systems
- Selected Topics of Marine Machinery Systems
- "Selected Chapters on Refrigeration and Low-Temperature Refrigeration"
- Environmental Refrigeration

**ZNANSTVENOISTRAŽIVAČKI RAD | SCIENTIFIC RESEARCH**

- Istraživanja na toplinskim aparatima i uređajima, izmjenjivačima topline i toplinskim spremnicima koja obuhvaćaju teorijska i laboratorijska istraživanja prijelaza topline, prijenosa mase te izmjene topline pri promjeni faza; istraživanja i optimizacija sustava grijanja i klimatizacije te sustava za korištenje obnovljivih izvora energije; istraživanja na području rashladne tehnike koja obuhvaćaju kompresijske i apsorpcijske rashladne uređaje i dizalice topline; istraživanja u području energetske učinkovitosti i optimizacija termotehničkih sustava grijanja, hlađenja i klimatizacije; istraživanja utjecaja parametara vlažne pare na proces erozije rotorskih lopatica toplinskih turbina; istraživanja erozije korozije protočnog dijela parnih turbina; istraživanja mogućnosti smanjenja emisije štetnih tvari motora s unutarnjim izgaranjem uz zadržavanje niske specifične potrošnje goriva te s ciljem povećanja specifične snage i pouzdanosti u preuzimanju naglih opterećenja snage kod motora s prednabijanjem; istraživanja iz broskog strojarstva s ciljem optimalnog i energetski racionalnog vođenja brodskih pogonskih sustava; istraživanja na području optimizacije energetskih procesa; istraživanja na području smanjenja emisija štetnih sastojaka iz energetskih i procesnih postrojenja.

Research on heat devices, heat exchangers and heat storages which encompass theoretical and laboratory research of heat and mass transfer, as well as heat transfer during phase change processes; research and optimization of heating and cooling systems, as well as of renewable energy systems; research into the field of refrigeration which embraces compression and absorption cooling devices and heat pumps; research into energy efficiency and optimization of HVAC&R systems; research into influence of wet steam parameters on the erosion process of rotor turbine blades; research into erosion - corrosion in the flowing part of steam turbines; research into reducing pollution species emission of internal combustion engines while retaining low specific fuel consumption and aiming at increasing specific power and reliability by sudden overload of a super charged engine; research to field of marine engineering aiming at the optimizing ships power plant control; investigation into optimization of energy processes; investigation into the field of emission reduction from energy and process facilities.

- **Optimizacija energetske učinkovitosti izmjenjivača topline (HEXENER), istraživački projekt financiran od Hrvatske zaklade za znanost, 2017.-2021., voditeljica projekta prof. dr. sc. Anica Trp.**  
Optimisation of energy systems; Environmental protection in energy plants
- **Članovi Zavoda uključeni su u rad istraživačkog projekta financiranog od Hrvatske zaklade za znanost pod nazivom Povećanje energetske učinkovitosti izmjenjivača topline (HEXENER) voditeljice prof. dr. sc. Anice Trp.**  
The members of the Department are involved in the work of a research project financed by the Croatian Science Foundation entitled Enhancement of the heat exchanger energy efficiency (HEXENER), project leader D. Sc. Anica Trp.

**PROJEKTI | PROJECTS**

- **Povećanje energetske učinkovitosti izmjenjivača topline (HEXENER), istraživački projekt financiran od Hrvatske zaklade za znanost, 2017.-2021., voditeljica projekta prof. dr. sc. Anica Trp.**  
Enhancement of the heat exchanger energy efficiency (HEXENER), research project financed by the Croatian Science Foundation, 2017-2021, project leader Prof. D. Sc. Anica Trp.
- **Akumulacija i izmjena toplinske energije u sustavima obnovljivih izvora energije, potpora znanstvenim istraživanjima Sveučilišta u Rijeci, voditeljica prof. dr. sc. Anica Trp.**  
Thermal energy storage and heat transfer in a renewable energy systems, support for scientific research, University of Rijeka, head prof. D. Sc. Anica Trp.
- **Optimizacija dizalice topline i rashladnih sustava koji koriste radne tvari niskog utjecaja na globalno zatopljenje korištenjem numeričkih simulacija, potpora znanstvenim istraživanjima Sveučilišta u Rijeci, voditelj prof. dr. sc. Branimir Pavković.**  
Optimization of heat pumps and refrigeration systems with low global warming potential refrigerants using numerical simulation, support for scientific research, University of Rijeka, head prof. D. Sc. Branimir Pavković.

**PUBLIKACIJE | PUBLICATIONS****RADOVI U ČASOPISIMA | JOURNAL PAPERS**

- Pelić, V.; Mrakovčić, T.; Bukovac, O.; Valčić, M. Development and Validation of 4 Stroke Marine Diesel Engine Numerical Model, Pomorski zbornik, ISSN: 0554-6397, 3, 359-372, 2020, Rijeka
- Glažar, V.; Trp, A.; Lenić, K. Optimization of air-water microchannel heat exchanger using response surface methodology, International journal of heat and mass transfer, ISSN: 0017-9310 157, 2020, Oxford, United Kingdom
- Mrzljak, V.; Blečić, P.; Anđelić, N.; Lorencin, I. Energy and exergy analyses of forced draft fan for marine steam propulsion system during load change, Journal of Marine Science and Engineering, ISSN: 2077-1312, 7 (11), 1-26, 2019, Basel, Švicarska

- Lorencin, I.; Anđelić, N.; Mrzljak, V.; Car, Z. Multilayer perceptron approach to condition-based maintenance of marine CODLAG propulsion system components, *Pomorstvo: Scientific Journal of Maritime Research*, ISSN: 1332-0718, 33 (2), 181-190, 2019, Rijeka
- Kocijel, L.; Mrzljak, V.; Čohodar Husić, M.; Čekić, A. Numerical Analysis of Fuel Injector Nozzle Geometry-Influence on Liquid Fuel Contraction Coefficient and Reynolds Number, *Pomorski zbornik*, ISSN: 0554-6397, 57 (1), 23-45, 2019, Rijeka
- Mrzljak, V.; Anđelić, N.; Lorencin, I.; Car, Z. Analysis of Gas Turbine Operation before and after Major Maintenance, *Pomorski zbornik*, ISSN: 0554-6397, 57 (1), 57-70, 2019, Rijeka
- Lorencin, I.; Anđelić, N.; Mrzljak, V.; Car, Z. Genetic algorithm approach to design of multi-layer perceptron for combined cycle power plant electrical power output estimation, *Energies* ISSN: 1996-1073, 12 (22), 1-26, 2019, Basel, Švicarska
- Poljak, I.; Orović, J.; Mrzljak, V.; Bernečić, D. Energy and Exergy Evaluation of a Two-Stage Axial Vapour Compressor on the LNG Carrier, *Entropy*, ISSN: 1099-4300, 22 (1), 1-19, 2020, Basel, Švicarska
- Poljak, I.; Orović, J.; Knežević, V.; Mrzljak, V. LNG carrier main steam turbine reliability in the exploitation period of time, *TransNav: International Journal on Marine Navigation and Safety of Sea Transportation*, ISSN: 2083-6473, 14 (1), 39-42, 2020, Gdynia, Poljska
- Kocijel, L.; Poljak, I.; Mrzljak, V.; Car, Z. Energy Loss Analysis at the Gland Seals of a Marine Turbo-Generator Steam Turbine, *Tehnički glasnik*, ISSN: 1846-6168, 14 (1), 19-26, 2020, Koprivnica
- Poljak, I.; Glavan, I.; Orović, J.; Mrzljak, V. Three Approaches to Low-Duty Turbo Compressor Efficiency Exploitation Evaluation, *Applied Sciences*, ISSN: 2076-3417, 10 (10), 1-20, 2020 Basel, Švicarska
- Kocijel, L.; Mrzljak, V.; Glažar, V. Conversion of A medium heavy heating oil tank into A heat storage tank, *Heat and Mass Transfer*, ISSN: 0947-7411, 56 (3), 871-890, 2020, Berlin, Njemačka
- Kocijel, L.; Mrzljak, V.; Glažar, V. Numerical analysis of geometrical and process parameters influence on temperature stratification in a large volumetric heat storage tank *Energy*, ISSN: 0360-5442, 194, 1-21, 2020, London, Velika Britanija
- Škopac, L.; Medica-Viola, V.; Mrzljak, V. Selection Maps of Explicit Colebrook Approximations according to Calculation Time and Precision, *Heat Transfer Engineering*, ISSN: 0145-7632, 1-15 2020, Abingdon, Velika Britanija
- Medica-Viola, V.; Mrzljak, V.; Anđelić, N.; Jelić, M. Analysis of Low-Power Steam Turbine With One Extraction for Marine Applications, *NAŠE MORE: znanstveni časopis za more i pomorstvo*, ISSN: 0469-6255, 67 (2), 87-95, 2020, Dubrovnik
- Car, Z.; Baressi Šegota, S.; Anđelić, N.; Lorencin, I.; Mrzljak, V. Modeling the Spread of COVID-19 Infection Using a Multilayer Perceptron, *Computational and Mathematical Methods in Medicine*, ISSN: 1748-670X, 1-10, 2020, London, Velika Britanija
- Kocijel, L.; Mrzljak, V.; Glažar, V. Pressure drop in large volumetric heat storage tank radial plate diffuser, *Journal of Energy Storage*, ISSN: 2352-152X, 29, 1-18, 2020, London, Velika Britanija
- Medica-Viola, V.; Baressi Šegota, S.; Mrzljak, V.; Štifanić, D. Comparison of conventional and heat balance based energy analyses of steam turbine, *Pomorstvo: Scientific Journal of Maritime Research*, ISSN: 1332-0718, 34 (1), 74-85, 2020, Rijeka
- Mrzljak, V.; Kudláček, J.; Begić-Hajdarević, Đ.; Musulin, J. The Leakage of Steam Mass Flow Rate through the Gland Seals-Influence on Turbine Produced Power, *Pomorski zbornik* ISSN: 0554-6397, 58 (1), 39-56, 2020, Rijeka

- Poljak, I.; Bielić, T.; Mrzljak, V.; Orović, J. Analysis and Optimization of Atmospheric Drain Tank of Lng Carrier Steam Power Plant, *Journal of Marine Science and Engineering*, ISSN: 2077-1312, 8 (8), 1-19, 2020, Basel, Švicarska

## MEĐUNARODNI KONGRESI | INTERNATIONAL CONGRESSES

- Batista, J.; Lenić, K.; Trp, A.; Torbarina, F. A comparison study of sensible and latent thermal energy storage used in domestic hot water solar heating system, *14th International Renewable Energy Storage Conference (IRES2020)*, 2020, Düsseldorf, Njemačka
- Kirinčić, M.; Trp, A.; Lenić, K.; Wolf, I. Experimental investigation on melting of paraffin in latent thermal energy storage, *Proceedings of the 14th International Renewable Energy Storage Conference*, 2020, Düsseldorf, Njemačka
- Kirinčić, M.; Trp, A.; Lenić, K.; Torbarina, F. Experimental analysis of latent thermal energy storage charging and discharging, *Proceedings of EuroSun 2020: 13th International Conference on Solar Energy for Buildings and Industry*, 2020, Atena, Grčka
- Mrzljak, V.; Baressi Šegota, S.; Kocijel, L.; Prpić-Oršić, J. Energy (isentropic) analysis of three-cylinder steam turbine with re-heating, *INTERNATIONAL SCIENTIFIC CONFERENCE HIGH TECHNOLOGIES. BUSINESS. SOCIETY 2020 - PROCEEDINGS* ISSN 2535-0005, 1, 29-32 2020, Sofija, Bugarska
- Mrzljak, V.; Prpić-Oršić, J.; Lorencin, I.; Anđelić, N. Thermodynamic analysis of three-cylinder steam turbine from combined cycle power plant, *INTERNATIONAL SCIENTIFIC CONFERENCE TECHNICAL SCIENCES. INDUSTRIAL MANAGEMENT. 2020 - PROCEEDINGS*, ISSN 2535-0196, 1, 23-26, 2020, Sofija, Bugarska
- Mrzljak, V.; Prpić-Oršić, J.; Poljak, I.; Baressi Šegota, S. Exergy analysis of steam condenser at various loads during the ambient temperature change, *INTERNATIONAL SCIENTIFIC CONFERENCE MACHINES. TECHNOLOGIES. MATERIALS 2020 - Winter Session - PROCEEDINGS*, ISSN 2535-0021, 1, 14-17, 2020, Sofija, Bugarska
- Mrzljak, V.; Prpić-Oršić, J.; Medica-Viola, V.; Anđelić, N. The change in energy flow streams for main marine propulsion steam turbine at different loads, *XXVIII INTERNATIONAL SCIENTIFIC CONFERENCE Trans & MOTAUTO 2020 - PROCEEDINGS*, ISSN 1313-5031, 1, 8-11, 2020, Sofija, Bugarska
- Prpić-Oršić, J.; Mrzljak, V.; Baressi Šegota, S.; Lorencin, I. Solver parameter influence on the results of multilayer perceptron for estimating power output of a combined cycle power plant, *V INTERNATIONAL SCIENTIFIC CONFERENCE - INDUSTRY 4.0 - SUMMER SESSION - 2020 - PROCEEDINGS*, ISSN 2535-0153, 1, 8-11, 2020, Sofija, Bugarska
- Mrzljak, V.; Prpić-Oršić, J.; Musulin, J.; Štifanić, D. Energy and exergy analysis of deaerator from combined-cycle power plant, *VIII INTERNATIONAL SCIENTIFIC CONFERENCE-TECHNICS. TECHNOLOGIES. EDUCATION. SAFETY, 2020 - PROCEEDINGS*, ISSN 2535-0315, 1, 5-8, 2020, Sofija, Bugarska
- Orović, J.; Mrzljak, V.; Poljak, I. Analysis of auxiliary exergy flow stream during the change in marine steam propulsion system load, *NAŠE MORE 2019, 1st International Conference of Maritime Science & Technology, Conference Proceedings*, ISBN 978-953-7153-52-6, 1, 470-480, 2019, Dubrovnik

## MEĐUNARODNA SURADNJA | INTERNATIONAL COLLABORATIONS

- ASHRAE – American Society of Heating, Refrigerating and Air-Conditioning Engineers. California Institute of Technology, SAD, USA
- Dipartimento di energetica, Università degli studi di Trieste, Italija, Italy

- *Dipartimento di energetica, Politecnico di Milano, Italija, Italy*
- *EURAMMON - a joint initiative by companies, institutions and individuals committed to increasing the use of natural refrigerants, Frankfurt, Njemačka, Germany*
- *Faculty of Mechanical Engineering, University of Ljubljana, Slovenija, Slovenia*
- *GRETh, Bâtiment Lynx, SavoieTechnolac, Le Bourget du Lac – Cedex, Francuska, France*
- *Institute of Energy Technology, ETH Zürich, Švicarska, Switzerland*
- *International Institute of Refrigeration, Paris, Francuska, France*
- *ISES – The International Solar Energy Society, Freiburg, World Organisation, Germany/ Njemačka ISES Europe Freiburg, Njemačka, Germany*
- *Laboratory for Heating, Sanitary and Solar Technology, University of Ljubljana, Slovenija, Slovenia*
- *Research and Development Center, Compagnie Industrielle d'Applications Thermiques (CIAT), Culoz, Francuska, France*





# SLUŽBE

DEKANAT, TAJNIŠTVO

RAČUNALNI CENTAR

STUDENTSKA EVIDENCIJA

KNJIŽNICA

**6** stručne službe  
professional and administrative staff

# 6.1 knjižnica library



**Sanja Orešković** prof. i dipl. knjižničarka prof., grad. librarian  
*voditeljica*  
*head*



**mr. sc. Mario Šlosar-Brnelić** dipl. knjižničar grad. librarian

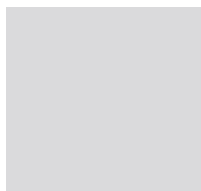
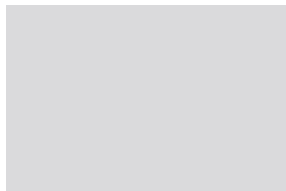

Knjižnica Tehničkog fakulteta Sveučilišta u Rijeci dio je znanstvene, istraživačke i obrazovne djelatnosti Fakulteta. Obavlja poslove oblikovanja i izgradnje knjižničkog fonda (nabava, stručna obrada), pružanja knjižničnih usluga korisnicima (posudba i korištenje građe, informacijsko-edukacijsku djelatnost) te ostale poslove koji proizlaze iz tih procesa.

Korisnici knjižnice su redovni i izvanredni studenti, nastavno osoblje i stručni suradnici Fakulteta, ali i ostali članovi šire društvene zajednice koji se bave znanstvenim i stručnim radom, a usluge knjižnice koriste po posebnim uvjetima. Knjižnica funkcionira kao informacijsko, izobrazbeno i komunikacijsko središte. Nalazi se u prizemlju zgrade Fakulteta, gdje su na 403 m<sup>2</sup>, na dvije etaže, smještene čitaonica, računalna čitaonica te otvoreni i zatvoreni fond.

Čitaonica se sastoji od trideset i tri mjesta za učenje i korištenje prijenosnih računala s priključcima na mrežu. Računalna čitaonica ima dvadeset i četiri mjesta s osam računala namijenjenih istraživanju i učenju; preko njih studenti imaju pristup bazama podataka i katalozima svih knjižnica. Nedavnom modernizacijom knjižničkog sustava, Knjižnica je integrirana u knjižnični sustav Sveučilišta u Rijeci, dodano je niz novih

The Library of the Faculty of Engineering, University of Rijeka is a part of the scientific, research and educational activities of the Faculty. It performs tasks of designing and construction of the library collection (procurement, expertise), the provision of library services to users (loan and the use of materials, information and educational activities) and other matters arising from these processes.

The Library is used by full and part-time students, faculty and professional staff of the Faculty but also by other members of the wider community engaged in scientific and professional work who use library facilities under special conditions. Therefore, the library functions as a media, education and communication center. It is located on the ground floor of the Faculty, namely on two floors covering 403 m<sup>2</sup> where there are situated a Reading Room, computer Reading Room, Open and Closed-End Fund. The Reading Room consists of thirty-three places for learning and using laptop computers with connections to the network. The Computer Reading Room has twenty-four places with eight computers intended for research and learning; through them, students have access to licensed databases and catalogs of all libraries.

funkcionalnosti i usluga i omogućeno je pretraživanje svih baza kroz jedan sustav. Pomoću Discovery servisa, jedinstvenog sučelja za pretraživanje, omogućeno je pretraživanje skupnog kataloga Sveučilišta čime i kataloga svih knjižnica Sveučilišta, pretplaćenih baza podataka dostupnih na Fakultetu i Sveučilištu u Rijeci, portala znanstvenih časopisa RH HRČAK i drugih odabranih znanstvenih izvora u slobodnom pristupu na internetu.

Knjižnični fond Knjižnice je svojim sadržajem i obimom prilagođen znanstvenoistraživačkom programu rada na Fakultetu. Kontinuirano se dopunjava, obnavlja i osuvremenjuje pri čemu se težište stavlja na nabavu literature iz tehničkih znanosti, elektrotehnike, brodogradnje, računarstva. Početkom 2019. godine, knjižnični fond iznosi oko 22000 svezaka omeđenih publikacija te oko 750 naslova domaćih i stranih periodičkih publikacija. Uz klasičnu posudbu tiskane građe, pridaje se pažnja i pretraživanju i odabiru relevantne građe prema individualnim potrebama korisnika kao i njihovoj edukaciji za samostalno pretraživanje izvora informacija. Knjižnica, prema zahtjevima korisnika, vrši usluge i međuknjižnične posudbe.

Uključeni smo u sustav upravljanja kvalitetom ISO 9001.

With recent modernization of the library system, the Library has been integrated into the library system of the University of Rijeka, a number of new features and services have been added and searches over databases through one system enabled. Using the Discovery Service as a unified search interface, it is now possible to search not only over the Union University Catalogue but also over the catalogs of all the libraries of the University, subscribed databases available on the Faculty and the University of Rijeka, the central portal of Croatian scientific journals named RH HRČAK and other selected scientific resources freely accessible on the Internet.

The library fund of the Library is in its funding sources, contents and scope adjusted to scientific research program at the Faculty. It has been continuously complemented, renewed and modernised whereby the emphasis has been placed on the acquisition of literature in engineering sciences, electrical engineering, naval architecture and computing. In early 2015 the library fund covered about 22,000 volumes of monographs and 750 titles of domestic and foreign periodicals. However, apart from lending the classic printed materials, due attention is also given to the search and selection of relevant material for individual search of sources of information according to the individual needs of users as well as their education. The Library provides services and interlibrary loans meeting thus the requirements of their users.

It is also worth pointing out that the Library and its members are involved in the quality management system ISO 9001 standard.

## 6.2 računalni centar computer center



**Domagoj Crljenko**, dipl. ing. m.eng.

*voditelj  
head*



**Damir Koščić**, dipl. ing. m.eng.

*stručni suradnik  
associate*



**Tatjana Škorjanc**, dipl. ing. m.eng.

*stručni suradnik  
associate*



**Siniša Vukotić**

*tehnički suradnik  
associate*

### RAČUNALNI KABINETI

- Računalni kabinet 1: 20 + 1 računalo
- Računalni kabinet 2: 20 + 1 računalo
- Računalni kabinet 3: 20 + 1 računalo
- Računalni kabinet 4: 16 + 1 računalo
- Računalni kabinet 5: 10 + 1 računalo
- Računalni kabinet 6: 20 + 1 računalo
- Računalni kabinet 7: 20 + 1 računalo
- Računalni kabinet 8: 20 + 1 računalo

### COMPUTER CLASSROOMS

- Computer Classroom 1: 20 + 1 computers
- Computer Classroom 2: 20 + 1 computers
- Computer Classroom 3: 20 + 1 computers
- Computer Classroom 4: 16 + 1 computers
- Computer Classroom 5: 10 + 1 computers
- Computer Classroom 6: 20 + 1 computers
- Computer Classroom 7: 20 + 1 computers
- Computer Classroom 8: 20 + 1 computers



## 6.3 financijska služba accounting division



**Ana Mirković Pavlović**, mag. oec. grad. economist  
*voditeljica*  
*head*

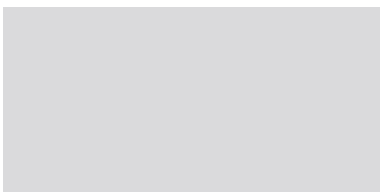

**Goran Brodarac**, mag. oec. grad. economist  
*računovodstveni poslovi*  
*accounting activities*

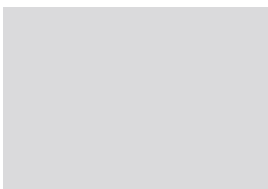

**Ariana Gregur**, dipl.oec. grad. economist  
*financijski poslovi*  
*financial activities*

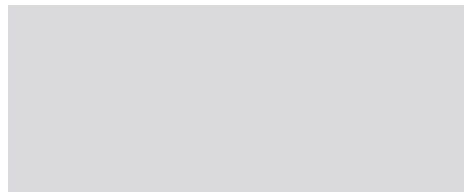

**Ana Šutalo**, struc. spec. oec. spec. grad. economist  
*financijski poslovi*  
*financial activities*

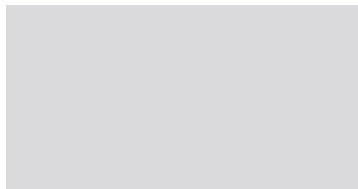

Financijska služba obavlja financijske i računovodstvene poslove. Financijska služba vodi računa o zakonitosti financijskog poslovanja, obavlja sve isplate vezane uz plaće, autorske honorare i ugovore o djelu, kontrolira, obračunava i isplaćuje putne naloge, plaća račune u tuzemstvu i inozemstvu, knjiži na računima glavne knjige sve poslovne događaje, sastavlja prijedlog financijskog plana Fakulteta te mjesečne, tromjesečne, polugodišnje i godišnje izvještaje, kontaktira s Ministarstvom znanosti i obrazovanja, Sveučilištem u Rijeci, Poreznom upravom, FINA-om, Revizijom, bankama i usklađuje svoje poslovanje i izvještaje s tim subjektima iz okruženja.

The accounting division performs financial and accounting activities. Specifically, it takes into account the legality of the financial business and performs all payments related to salaries, author's fees and work contracts. Furthermore, the accounting division controls, calculates and pays travel orders, pays domestic and foreign accounts, records all business events in the ledger accounts, compiles the proposal of the Faculty's financial plan as well as the monthly, quarterly, semi-annual and annual reports. It also maintains contact with the Ministry of Science and Education, the University of Rijeka, the Tax Office, the Financial Administration, the Audit, the banks and it coordinates its own business and reports with all these entities from the area.

## 6.4 služba nabave i komercijale procurement and commerciale office

## 6.5 služba općih i kadrovskih poslova general and personnel office



**Robert Mohorić**, dipl. oec. grad. economist

*voditelj  
head*



**Tijana Čupurdija**,  
mag. oec. grad. economist

*ekonom za inventar  
inventory economist*



**Bruna Martinović**,  
mag. oec. grad. economist

*ekonom za inventar  
inventory economist*



**Mladen Ostrogović**,  
mag. oec. grad. economist

*ekonom za potrošni materijal  
economist for consumables*

Služba obavlja poslove komercijale, nabave i ekonomata. Vodi poslove u vezi nabave roba, usluga i radova, izradom plana nabave robe, usluga i radova za tekuću godinu, priprema i provodi postupke odabira godišnjih dobavljača, vodi evidenciju nabave male i velike vrijednosti, administrativno provodi postupke nabave prema Zakonu o javnoj nabavi, priprema dokumentaciju ovisno o načinu nabave, kontaktira s dobavljačima, sudjeluje u pripremanju odluka i prijedloga ugovora, pohranjuje cjelokupnu dokumentaciju o nabavi, preuzima naručenu robu, vodi evidenciju o sitnom inventaru, osnovnim sredstvima i potrošnom materijalu, radi na izradi, održavanju i unapređenju baza podataka Službe te održava i unapređuje sustav kontrole kvalitete u Službi.

Skriptarnica je u zakupu firme TEHNIČAR COPYSERVIS d.o.o., Zagreb.

This office performs commercial, procurement and economic services. It runs services connected with the procurement of goods and services, prepares and implements the procedures for the annual selection of suppliers, contracts with suppliers, receives ordered goods, keeps records of small inventories, basic resources and consumables, works on the office's databases and maintains and improves the system of quality control of its services.

The copy shop is leased by the firm TEHNIČAR COPYSERVIS Ltd, Zagreb.

**Marijana Burić Redžović**, dipl. iur. grad.law.

*voditeljica opće i kadrovske službe  
general and personnel office head*



**Snježana Mikuličić**

*voditeljica kadrovskih poslova  
personnel operation manager*



**Lidija Petričić**

*administrativna tajnica  
administrative secretary*



### TAJNICE ZAVODA | DEPARTMENT SECRETARY:

**Valnea Burić Marohnić**, mag. cult.



**Tina Kažić**, struč. spec. eoc.



**Natalija Forgić**



**Lovorka Malinić**



**Patricija Vukić**



SPREMAČICE | CLEANING STAFF:



Snježana Ban



Danijela Ćuk



Marina Djaković



Marica Gnjatović



Valentina Kajfeš



Mirjana Košpić



Julijana Nenadović



## 6.6 služba studentske evidencije student's registrar and affairs office



**Žarko Burić**, mag. ing. m.eng.

*voditelj  
head*



**Antonela Čaleta**

*voditelj ostalih  
ustrojstvenih jedinica  
head of other  
organizational units*



**Tanja Veljčić**

*voditelj odsjeka III  
head of department III*



**Adriana Muždeka Prodanović**

*voditelj ostalih ustrojstvenih jedinica  
head of other organizational units*



**Darko Vidučić**

*stručni savjetnik ISVU  
ISVU Advisor*

Služba studentske evidencije Fakulteta obavlja sve poslove vezane uz potrebe studenata. Zaprima i obrađuje dokumentaciju za razredbeni postupak, obavlja upis studenata u prvu i u više studijske godine, priprema dokumentaciju studenata za završni ili diplomski ispit, organizira promocije završenih studenata, prima i izdaje razne zahtjeve, uvjerenja i potvrde, izrađuje izvješća prostručne analize za potrebe Fakulteta te vodi potrebnu korespondenciju i daje izvješća zainteresiranim strankama.

The students' Registrar and Affairs Office is in charge of all the issues pertaining to students' needs. It collects and manages documentation for the admission exams, manages the enrolment of students to all the study years, prepares students' documents for the graduation exams, organizes the commencement of graduates, receives and delivers various requests and certificates, produces reports and analyses as per Faculty need, manages the necessary correspondence and gives reports to interested parties.

## 6.7 tehnička služba technical and maintenance services



**Goran Bakotić**,  
struč. spec. ing. sec.

*voditelj  
head*



**Josip Jurasic**



**Frane Polegubić**



### DOMARI - KUĆEPAZITELJI | MAJOR - DOMO

**Miljenko Pujic**



Tehnička služba obavlja poslove održavanja, zaštite na radu i zaštite od požara. U sastavu Tehničke službe su i laboranti koji pod nadzorom nastavnika sudjeluju u pripremi, odnosno izvedbi dijela nastave.

**Bernardo Badurina**,  
bacc.ing. bacc.eng.



**Andrej Miljuš**



**Nevio Poniš**,  
dipl. ing. m.eng.



**Boris Šegota**



The Technical and Maintenance Services perform activities pertaining to maintenance, work safety and fire protection. Involved in the Technical Services are also laboratory technicians that, under supervision of teaching staff, participate in the preparation of performing parts of lectures.





## 7 studentske aktivnosti student activities

### 7.1 studentski zbor tehničkog fakulteta student council at the faculty of engineering



Studentski zbor Tehničkog fakulteta u Rijeci je najviše predstavničko tijelo studenata unutar Fakulteta. Rad Studentskog zbora definiran je Statutom Studentskoga zbora u kojemu su navedene i sljedeće zadaće:

- » biranje studentskog predstavnika u Skupštinu pri Studentskom zboru Sveučilišta u Rijeci,
- » biranje studentskih predstavnika u radna tijela Fakulteta i sudjelovanje u radu i odlučivanju tih tijela,
- » briga o kvaliteti života studenata, a posebice o kvaliteti studijskog procesa, studentskom standardu, ostvarivanju studentskih prava i drugim pitanjima važnim za studente Fakulteta,
- » predlaganje plana financiranja studentskih aktivnosti nadležnim tijelima Fakulteta,
- » poticanje izvannastavnih aktivnosti studenata Fakulteta,
- » obavljanje drugih poslova od interesa studenata Fakulteta.

RITEH Game Nights bio je najznačajniji projekt Studentskoga zbora ove akademske godine. Održavao se posljednjega petka u mjesecu, od listopada do veljače, a tad je epidemija SARS-CoV-2 virusa, nažalost, obustavila sva društvena događanja na Fakultetu.

Osim RITEH Game Nightsa, Zbor se založio za preuređenje studentske prostorije pa je opremljena novim namještajem, a planira se i dodatno opremiti tehničkom opremom koja će poslužiti za multimedijске zabave među studentima.

Studentski zbor je u akademskoj 2019./2020 godini brojao ukupno 27 članova (14 predstavnika i 13 zamjenika) koji su imali pravo biti članovima Studentskog zbora.

The Student Council of the Faculty of Engineering in Rijeka is the highest representative body of the students within the Faculty whose work is defined by the Statute of the Student Council where the following activities are mentioned:

- » election of the students' representative for the Student Council of the University of Rijeka,
- » election of student representatives who are actively involved in the work of the Faculty Council participating in decision making,
- » care of the quality of students' lives, especially the quality of study programs, the student standard, the realization of students' rights, and other issues of relevance for the students of the Faculty,
- » proposing the funding plan for students' activities to the competent authorities,
- » promoting extracurricular activities of the students of the Faculty,
- » any other activity of interest for the students of the Faculty.

The most important project that was held by the Student Council was RITEH Game Nights which has, already traditionally, been held every last Friday monthly since October until February, when the epidemic of SARS-CoV-2 virus unfortunately suspended all social gatherings at the Faculty. Except for RITEH Game Nights, the Student Council has taken up the obligation to refresh the students' room whose furniture has been renewed and there are plans to equip it with modern technical equipment which will be used for students' multimedial activities.

The Student Council in the 2019./2020. academic year had a total of 27 members (14 representatives and 13 deputies) who had the right to be a part of the Student Council.

## članovi studentskog zbora po izbornim jedinicama members, listed by electoral wards

I PREDDIPLOMSKI SVEUČILIŠNI STUDIJ STROJARSTVA I BRODOGRADNJE  
I UNDERGRADUATE UNIVERSITY STUDY OF MECHANICAL ENGINEERING AND NAVAL ARCHITECTURE

PREDSTAVNIK | REPRESENTATIVE

- » Ante Rašić
- » Daniel Ivaničić
- » Filip Hadrović-Pavišić
- » Maša Stanković
- » Petra Gugleta
- » Filip Bratoš

ZAMJENIK | DEPUTY

- » Bruno Belobrajdić
- » Franko Antić
- » Antun Lukić
- » Elena Miletić
- » Andrej Raguzin
- » Andro Golja

II PREDDIPLOMSKI SVEUČILIŠNI I DIPLOMSKI SVEUČILIŠNI STUDIJ ELEKTROTEHNIKE I RAČUNARSTVA I PREDDIPLOMSKI STRUČNI STUDIJ ELEKTROTEHNIKE  
II UNDERGRADUATE AND GRADUATE STUDIES OF ELECTRICAL AND COMPUTER ENGINEERING AND UNDERGRADUATE VOCATIONAL STUDIES OF ELECTRICAL ENGINEERING

PREDSTAVNIK | REPRESENTATIVE

- » Erik Smoljan  
(predsjednik / president)
- » Luka Vukonić
- » Denis Mijolović  
(pravobranitelj / pleader)
- » Romario Novak
- » Azra Subašić  
(potpredsjednik / vice president)
- » Toni Polonijo
- » Vito Medved

ZAMJENIK | DEPUTY

- » Roko Katalinić
- » Marin Vidaković-Lipovac
- » Damjan Batinović
- » Tibor Jaklin
- » Josipa Raspor

III POSLIJEDIPLOMSKI SVEUČILIŠNI (DOKTORSKI) STUDIJ  
III POSTGRADUATE DOCTORAL STUDIES IN THE AREA OF ENGINEERING SCIENCES

PREDSTAVNIK | REPRESENTATIVE

- » Damjan Banić
- » Maja Marković

ZAMJENIK | DEPUTY

- » Sandra Kvaternik
- » David Ištoković



## 7.2 IEEE studentski ogranak sveučilišta u rijeci IEEE university of rijeka student branch



IEEE studentski ogranak Sveučilišta u Rijeci nastao je 2006. godine kao jedan od studentskih ograna unutar Hrvatske sekcije IEEE. Cilj mu je okupljanje studenata iz različitih područja tehničkih znanosti i organizacija raznovrsnih događanja. Pod okriljem Ogranka održavaju se predavanja iz područja tehničkih znanosti, natjecanja, radionice i razna druženja. Time se studentima omogućuje razmjena ideja i iskustava, sklapanje niza korisnih poznanstava, ali i nerazdvojenih prijateljstava. Sve to vodi boljoj umreženosti i napretku na privatnom i poslovnom planu svake osobe.

Studentski ogranak u Rijeci je tijekom godina otvorio i dva podogranka te društva unutar IEEE-a. Podogranci koji djeluju u sklopu ogranka su Computer Society (CS) kojeg čine uglavnom studenti računarstva i Power and Energy Society (PES) koji okuplja studente elektrotehnike i energetike, uz koje imamo i aktivno Young Professionals (YP) društvo.

Studentski ogranak provodi brojne aktivnosti svake godine. Neke od njih bit će predstavljene u nastavku teksta.

### Organizirane aktivnosti

Od 2015. godine provodimo Pripremni seminar iz programiranja koji se održava u zadnjem tjednu rujna, prije samog početka akademske godine. Cilj seminara je upoznavanje studenata prve

The IEEE student branch of the University of Rijeka was established in 2006 as one of the student branches within the Croatian section of the IEEE. Its goal is to bring together students from various fields of engineering sciences and to organize various events. Therefore, under the auspices of the Branch, lectures in the field of engineering sciences, competitions, workshops and various gatherings are held. This enables students to exchange ideas and experiences, make a number of useful acquaintances, but also inseparable friendships. All this leads to better networking and progress in the private and business plan of each person.

Over the years, the Student Branch in Rijeka has opened two sub-branches of that society within the IEEE. The sub-branches that operate within the branch are the Computer Society (CS) which consists mainly of computer engineering students and the Power and Energy Society (PES) which brings together students of electrical engineering and power engineering as well as the Young Professionals (YP) society.

The student branch conducts a number of activities each year, some of which will be presented below.

godine studija na Tehničkom fakultetu u Rijeci s osnovnim znanjem iz programiranja. Na taj način studenti su spremniji pristupiti zadacima s kojima se susreću već u prvom semestru. Seminar je održan i ove godine u suradnji sa Zavodom za računarstvo Tehničkog fakulteta, pod vodstvom članova Studentskog ogranka Rijeka.

Uz sva stručna predavanja koja u godini organiziramo, prije nekoliko godina započeli smo s novim formatom predavanja pod nazivom „Success stories“. Pozivamo ljude s riječkog područja koji su nakon završetka studija svojim radom postigli veliki uspjeh na poslovnom i znanstvenom području, a i dalje djeluju na našem području i promiču znanost, aktivno sudjeluju u edukaciji novog kadra i, u konačnici, zapošljavaju mlade inženjere. Do sada smo organizirali šest takvih predavanja.

Svake godine se trudimo organizirati predavanja u kojima promoviramo nove i zanimljive tehnologije. Krajem 2019. godine organizirali smo Computer Society Congress (CSC). Predavači su bili predstavnici raznih tvrtki, udruga i sl., s raznolikim temama, od embedded programiranja u automobilske industriji, preko razvoja računalnih igara pa sve do interaktivnih predavanja (vježbi) na kojima su studenti mogli aktivno sudjelovati programirajući na svojim prijenosnim računalima. Kongres je bio otvoren za sve, ali primarno namijenjen studentima računarstva i osobama koje se bave tim područjem.

### Natjecanja

IEEE organizira natjecanja za svoje studentske članove. Najpopularnije natjecanje je Google Hash, globalno timsko natjecanje u programi-

### Organized activities

Since 2015, we have been conducting a Preparatory Seminar in Programming, which takes place in the last week of September, before the very beginning of the academic year. The aim of the seminar is to acquaint first year students of the Faculty of Engineering in Rijeka with basic knowledge in programming. In this way, students are more willing to approach the tasks they face in the first semester. The seminar was held this year in cooperation with the Department of Computer Engineering of the Faculty of Engineering, under the leadership of the members of the Student Branch of Rijeka.

In addition to all professional lectures that we organize in the year, a few years ago we started with a new format of lectures called "Success stories" where we invite people from the Rijeka area who after graduation achieved great success in business and science, but still work in our field and promote science, actively participate in the education of new staff and ultimately employ young engineers. So far, we have organized six such lectures.

Every year we try to organize lectures in which we promote new and interesting technologies. At the end of 2019, we organized the Computer Society Congress (CSC) where the lecturers were representatives of various companies, associations, etc. Topics varied from embedded programming in the automotive industry, through the development of computer games to interactive lectures (exercises) in which students could actively participate by programming on their laptops in addition to lectures. The congress was open to all, but it was primarily intended





ranju. Održava se jednom godišnje, početkom godine (veljača) i već godinama se naši članovi natječu. Kako bi timovi imali što bolje uvjete za rad, ogranak im svake godine pripremi zajedničku prostoriju na Tehničkom fakultetu gdje, uz računalnu opremu, imaju pristup ostaloj potrebnoj opremi, a počastimo ih hranom i pićem. U zadnje tri godine se promiče još jedno IEEE natjecanje i to je IEEE MadC, natjecanje u izradi mobilnih aplikacija. Već tri godine naši članovi su dio tima ambasadora koji promiču natjecanje, nude edukaciju i sami se natječu. I ove godine naši članovi su se prijavili i osvojili dijeljeno prvo mjesto u svijetu sa svojom aplikacijom za konferencije.

#### Suradnja

IEEE Studentski ogranak Sveučilišta u Rijeci aktivno surađuje s ostalim ogranacima u Hrvatskoj što utječe na unapređenje kvalitete i sadržaje aktivnosti na razini Hrvatske sekcije IEEE-a. Osim što blisko surađujemo s ostalim članovima IEEE-a, na lokalnoj razini surađujemo s brojnim drugim studentskim udrugama, organizacijama, fakultetima i tvrtkama. Rezultat suradnje je bolja umreženost naših članova s drugim aktivnim grupama, ali i bolji i kvalitetniji sadržaj kojega možemo ponuditi studentima, bolja promocija aktivnosti i njihova veća posjećenost. Neke od naših suradnji kroz prošlu i ovu godinu bila su sa Studentskim zborom Tehničkog fakulteta i Studentskim zborom Sveučilišta u Rijeci s kojima smo, između ostaloga, organizirali Computer Society Congress kongres, Alumni Tehničkog fakulteta s kojima smo organizirali stručna predavanja.

#### Ostale aktivnosti

Osim aktivnosti koje organiziramo, naši članovi

for computer engineering students and people working in the field.

#### Competitions

The IEEE organizes competitions for its student members. The most popular competition is Google Hash, a global team programming competition. It is held once a year, at the beginning of the year (around February) and our members have been competing for years. In order for the teams to have the best possible working conditions, the branch prepares a common room for them at the Faculty of Engineering every year, where they have access to other necessary equipment in addition to computer equipment, and we also treat them to food and drinks. In the last three years, another IEEE competition has been promoted and that is IEEE MadC, a competition in mobile application development. For three years now, our members have been part of a team of ambassadors who promote the competition, offer education and compete on their own. And this year, our members signed up and won a shared first place in the world with their conference app.

#### Cooperation

The IEEE Student Branch of the University of Rijeka actively cooperates with other branches in Croatia and improves the quality and content of activities at the level of the Croatian section of the IEEE. In addition to working closely with other IEEE members, we work with a number of other student associations, organizations, colleges, and firms locally. The result of cooperation is better networking of our members with other active groups of people, but also better and higher quality content that we can offer our

imaju priliku posjetiti brojne aktivnosti koje organiziraju drugi ogranaci u Hrvatskoj, a to su razni kongresi, stručna predavanja, radionice, svečane večere i slično.

#### Promocija

Upoznavanje studenata s radom Studentskog ogranka i IEEE-a aktivnost je od posebne važnosti. Kao neprofitna volonterska udruga, aktivnosti koje se organiziraju ovise o vremenu i volji koju članovi ogranka imaju te je stoga potrebno imati aktivno članstvo. To je naročito važno radi opstanka i nastavka rada ogranka. Najbolja promocija našega rada je kroz aktivnosti koje organiziramo, ali postoji i poseban dan početkom listopada kada se na razini IEEE-a promovira cjelokupni rad organizacije. IEEE Day smo u 2019. proslavili štandom u predvorju fakulteta na kojem su bili studenti-volonteri koji su upoznavali studente s radom IEEE-a. Cilj je bio privući nove članove.

Sve naše aktivnosti pronađite na našoj Facebook stranici ([www.facebook.com/ieeesbrijeka](http://www.facebook.com/ieeesbrijeka)) te službenoj IEEE stranici Hrvatske sekcije ([www.ieee.hr](http://www.ieee.hr)) gdje objavljujemo najave novih događaja, osvrte i slike održanih aktivnosti.

students, better promotion of activities and higher attendance. Some of our collaborations over the past and this year are with the Student Council of the Faculty of Engineering and the Student Council of the University of Rijeka with whom we organized, among others, the Computer Society Congress, Alumni of the Faculty of Engineering with whom we organized professional lectures, and others.

#### Other activities

In addition to the activities we organize, our members have the opportunity to visit numerous activities organized by other branches in Croatia, such as various congresses, professional lectures, workshops, gala dinners and the like.

#### Promotion

Introducing students to the work of the Student Branch and the IEEE activity is of particular importance. As a non-profit voluntary association, the activities that are organized depend on the time and will that the members of the branch have, and therefore it is necessary to have an active membership in order for the branch to survive and continue its work. The best promotion of our work is through the activities we organize, but there is also a special day in early October when the entire work of the organization is promoted at the IEEE level. In 2019, we celebrated the IEEE Day with a stand in the lobby of the faculty, where there were student volunteers who introduced students to the work of IEEE and their goal was to attract new members.

Find all our activities on our Facebook page ([www.facebook.com/ieeesbrijeka](http://www.facebook.com/ieeesbrijeka)) and the official IEEE page of the Croatian section ([www.ieee.hr](http://www.ieee.hr)) where we publish announcements of new events and pictures and a review of the activities held.

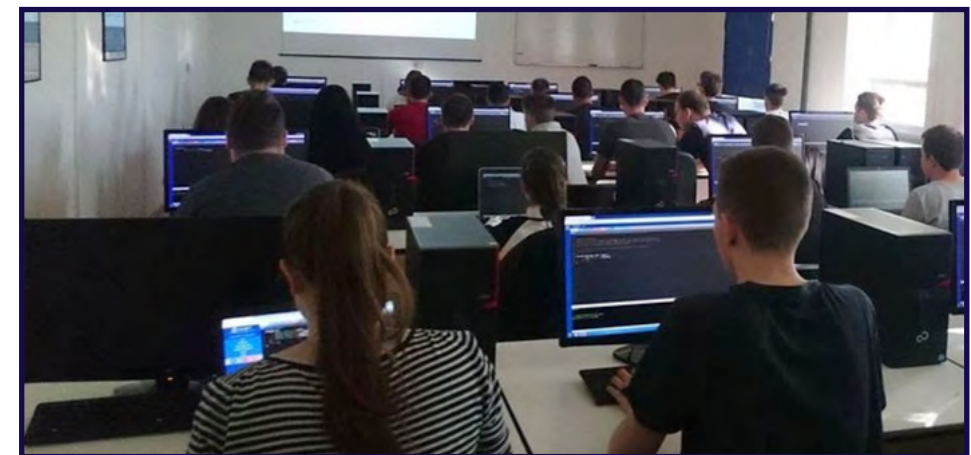

## 7.3 IAESTE



Početak akademske godine aktivno smo krenuli s radom i usmjerili se na Member raising i Job raising komponente. Kako je velik broj naših članova diplomirao 2019. godine, ostali smo na svega šest aktivnih članova pa je primarni cilj bio povećanje tog broja radi održavanja kvalitete i aktivnosti udruge. Održane su prezentacije udruge na Tehničkom i Građevinskom fakultetu te na Sveučilišnim odjelima u Rijeci što je rezultiralo povećanjem broj članova koji dolaze s različitih tehničkih i znanstvenih područja. Sudjelovanjem na JobFairu održanom na Tehničkom fakultetu, uspjeli smo ostvariti suradnju s nekoliko kompanija, kao što su primjerice IHC Engineering Croatia i JGL grupa. Također, naši članovi sudjelovali su u organiziranim druženjima studenata, kao što je npr. GETT (Get Together), u organizaciji IAESTE-a.

With the beginning of the academic year, we actively started with our work and aimed our forces to Member raising and Job raising components. Considering that a large number of our members graduated last year, we were left with only six active members, so our primary goal was to increase that number in order to maintain the quality and activities of our committee. We held presentations at the Faculty of Engineering, Faculty of Civil Engineering and at the Departments of Rijeka University, which resulted in gaining new members from different engineering and scientific areas. Participating at the JobFair, which was held at the Faculty of Engineering, helped us to achieve cooperation with larger companies in this area, as IHC Engineering Croatia and the JGL group. Furthermore, our members took part in student events, like GETT (Get Together), organised by IAESTE.

**IAESTE HRVATSKA**  
new experience today, new expert tomorrow

**IOU**  
iaestecroatia



Druga polovica godine, kao za svih, tako i za nas, obilježena je virusom, što je nama posebno teško palo zbog restrikcija putovanja koje su nas najteže pogodile. Ipak, prilagodili smo se situaciji kako smo najbolje znali pa je uvedena nova vrsta prakse - remote praksa, koja omogućuje rad od kuće. Ustrajali smo u radu pa smo vrijeme, koje bismo inače utrošili oko brige o praktikantima, iskoristili kako bismo još više unaprijedili i proširili naše djelovanje. Došlo je do promjene vodstva u udruzi. Izabrani su novi koordinatori koji su već tijekom ljeta počeli sa aktivnostima. Zbog toga ponosno možemo reći da trenutno brojimo čak 15 članova, što je najveći broj u posljednjih pet godina, iznimno smo aktivni na društvenim platformama, u tijeku smo priprema za internacionalni događaj JUMP, u organizaciji IAESTE, kojim promičemo našu državu, kulturu i običaje te se polako pripremamo za novu akademsku godinu, novi Job Raising i sve avanture koje nam donosi 2020./2021. akademska godina.

The second part of the semester was affected by the virus, which was especially hard for us because of the travel restrictions. However, we adapted to the situation and introduced a new type of internship - Remote internship, which enabled work from home. Moreover, we stayed persistent in our work and used our time to enhance and improve our activities. New leadership was selected and our coordinators started working during the summer. At this very moment we can proudly say that we count 15 members, which is the largest number in last five years. Our activity on social networking sites is constant and we are currently in the middle of the preparations for the JUMP event, which helps us to promote our country, culture and traditions. We are preparing ourselves for the next academic year, the new Job Raising event and all the adventures that the new 2020/2021 academic year brings.

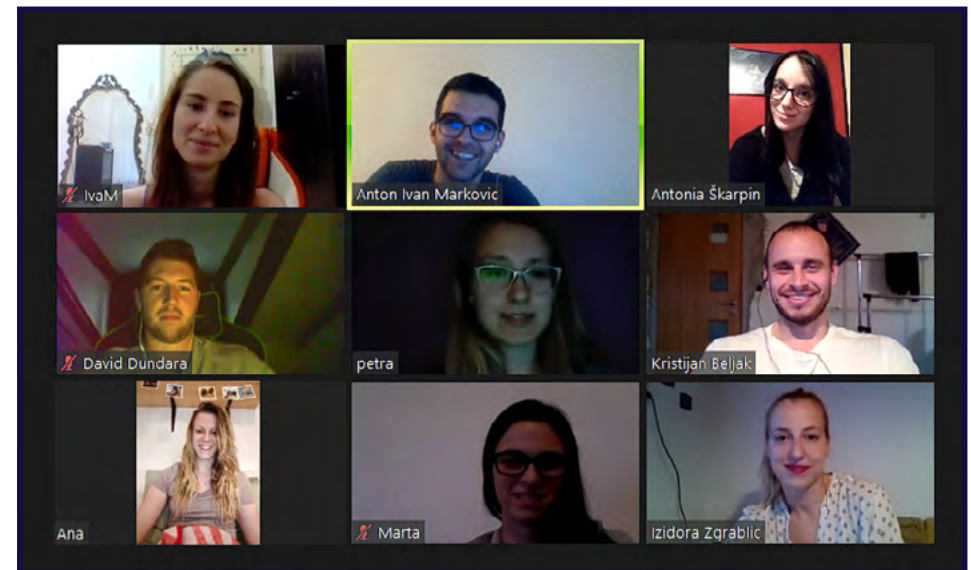

## 7.4 natjecanje timova studenata informatičara hrvatskih sveučilišta 2019 croatian collegiate programming contest 2019



Natjecanje timova studenata informatičara već dulji niz godina organizira Hrvatski savez informatičara (HSIN), kao izlučni dio u procesu stjecanja prava sudjelovanja na najprestižnijem svjetskom studentskom natjecanju u programiranju ACM ICPC. Timovi se sastoje od triju studenata s istog sveučilišta (ne moraju biti s istog fakulteta), a natjecanje se sastoji od rješavanja osam do deset zadataka u vremenskom periodu od pet sati. Programski jezici u kojima studenti mogu pokazati svoje znanje prilikom rješavanja problemskih zadataka su Python, C/C++ i Java na Linux platformi.

Zadatke za natjecanje i sustav za vrednovanje natjecateljskih rješenja osigurava Hrvatski savez informatičara. Prostor za natjecanje, kao i cjelokupnu organizaciju u kontekstu Sveučilišta u Rijeci, već četvrtu godinu zaredom, osigurao je Tehnički fakultet.

Ove akademske godine natjecanje se održalo se u nedjelju 27. listopada 2019. godine. U ukupnoj konkurenciji od 26 timova na razini Hrvatske, sudjelovala su i četiri studentska tima sa Sveučilišta u Rijeci. Tim studenata Tehničkog fakulteta, u sastavu Matija Dizdar, Erik Otović i Ivana Žužić, kao prvorangirani sa Sveučilišta u Rijeci, kvalificirao se na Central Europe Regional Contest (CERC 2019) koji je održan u Pragu kasnije iste godine.

Croatian Collegiate Programming Contest has been organized for many years by the Croatian Computer Science Association (CCSA), as a part in the process of acquiring the right to participate in the world's most prestigious students' programming competition ACM ICPC. Teams consist of three students from the same university (although they do not have to be from the same faculty), and the competition consists of solving 8 to 10 problems over a period of 5 hours. The programming languages, which students can utilize in order to demonstrate their skills in solving problem tasks, are Python, C / C ++ and Java on the Linux platform.

Problem tasks, and the system for automatic evaluation of the submitted solutions, are both provided by the Croatian Computer Science Association. The competition venue, as well as the entire organization in the context of the University of Rijeka, has been provided by the Faculty of Engineering, for the fourth year in a row.

This academic year, the contest was held on Sunday, October 27, 2019. Four student teams from the University of Rijeka competed among the altogether 26 Croatian teams. The students of the Faculty of Engineering, including Matija Dizdar, Erik Otović and Ivana Žužić, qualified for the Central Europe Regional Contest (CERC 2019) which was held in Prague later that year.

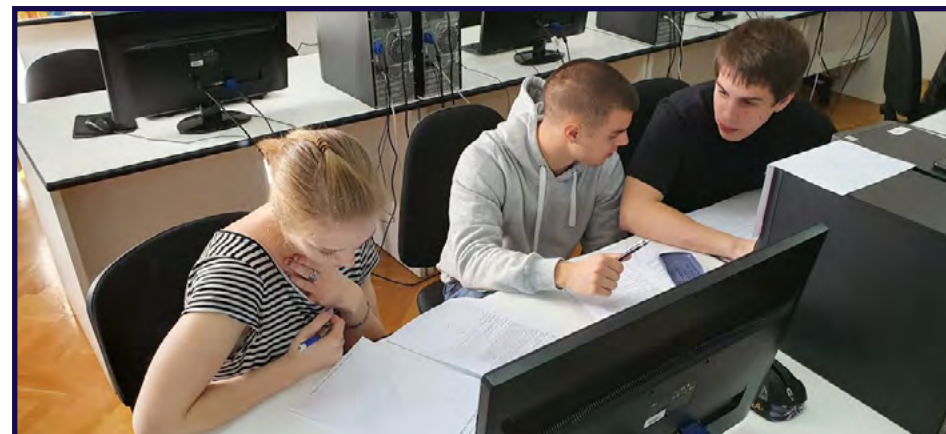

## 7.5 riteh racing team



Početkom akademske godine i nove sezone odredili smo dva cilja: poboljšanje rada prethodnoga bolida RRC5 i razvitak i proizvodnju novoga bolida RRC6. Također, pripremali smo se za nadolazeću sezonu natjecanja na kojoj smo ciljali na barem tri natjecanja, uz postizanje što boljeg rezultata. Iako je godina burno završila, početak je svakako vrijedan spomena kako bismo se upoznali i s ovogodišnjim vrijednim radom naših članova.

FS simpozij u Mađarskoj

S dolaskom novih članova, početkom studenoga otišli smo na redovno organizirano okupljanje entuzijasta u Formula Student svijetu, zvanom FS Symposium. Cilj odlaska u mađarski grad Győr je stjecanje znanja i vještina u raznim područjima inženjerstva u motorsportu. Deset naših članova, od čega četiri nova, prisustvovalo je ovom događanju.

Dan je bio ispunjen obilaženjem predavanja (po vlastitom izboru) koja su održavali razni stručnjaci, a večer druženjem s timovima iz drugih regija. Ovo je svakako bilo vrijedno iskustvo koje će svakoga studenta obogatiti novim znanjem i poznanstvima.

Radni vikend s timovima iz Ljubljane i Zagreba

Za vikend u listopadu organizirali smo druženje i prijenos znanja s našim bliskim timovima: Superior Engineering Ljubljana i FSB Racing Team iz Zagreba. Okupljanje se održalo u Velikom domu Platak gdje smo proveli dvije večeri. Pretresali

At the beginning of the academic year and season, we were set to two goals: to improve the performance of the previous RRC5 car and to develop and produce the new RRC6 car. Also, we were preparing for the upcoming season of competitions, for which we were aiming to compete at least three competitions, but also, of course, to achieve the best possible result. Although the year ended turbulently, the beginning is definitely worth mentioning in order to get to this year's hard work done by our members.

FS Symposium in Hungary

In line with the arrival of new members in early November, we went to a regularly-organized gathering of enthusiasts in the Formula Student world called the FS Symposium. The goal of going to the Hungarian city of Győr for such an event is to acquire knowledge and skills in various fields of engineering in motorsports (and in general). We attended the event with 10 members, of which 4 were new members. The way filled with a tour of lectures (of personal choice) held by various experts, and the evening socializing with teams from other regions. It was certainly a valuable experience for which each student will feel richer in knowledge and acquaintances.

Working weekend with teams from Ljubljana and Zagreb

For the weekend in October, we organized

smo razne interesantne teme, od ovjesa do razvoja električnog bolida (za kojega smo dobili vrijedne informacije od timova čiji bolidi imaju električni pogon), a tema za razgovor i diskusiju nije ponestala. Izuzetno smo zahvalni kolegama na razmjeni znanja, a utvrdili smo kako se uz suradnju, komunikaciju i međusobnu povezanost mogu postići zadani ciljevi.

Cars & Coffee

Kako nismo samo radoholičari koji vrijeme provode u garaži konstruirajući i sklapajući, pokazali smo sudjelovanjem na događaju kao što je Cars & Coffee. Naime, to je smotra luksuznih automobila održana na globalnoj razini, u kojoj je bila uključena i naša skromna, ali vrijedna formula RRC5, te smo se uspjeli pohvaliti svojim dotadašnjim uspjesima i prikupiti razne promatrače. Za nas nije bitan luksuz, već trud i ulaganje!

Nakon izmjena na prošlom bolidu RRC5, morali smo provjeriti efikasnost na testiranju. Testiranje smo obavili u više navrata na poznatoj lokaciji Automotodrom Grobnik. Testiranja sitne problematike završila su zadovoljavajućim rezultatom te smo mogli prebaciti fokus na izgradnju novog bolida, za kojeg garantiramo da će imati još bolje rezultate. Kvizovi krajem siječnja su pokazali izvrsne rezultate inženjerskog znanja naših članova: upali smo na natjecanje u Mađarskoj, ali najvažniji je prolazak na natjecanje koje je ujedno i najprestižnije - Formula Student natjecanje u Europi! S velikim ponosom smo nastavili raditi i pripremiti se za natjecanja, no dogodio se slučaj poznat svima – globalna pandemija COVID-19. S velikom žalošću morali smo privremeno zaustaviti rad na novom bolidu zbog nemogućnosti dolaska na Fakultet, ali i zbog nemogućnosti povratka naših članova iz drugih županija. Tako je naša nova šasija morala ostati gola na neko vrijeme. Uz neke poslove koji su se mogli napraviti preko računala, kao što su konstrukcije i simulacije, omogućili smo kontinuirani rad i u najteža vremena. Zbog pandemije su, naravno, i natjecanja bila otkazana, pa tako i FS Alpe Adria 2020 koja je uspjela stajati na nogama do tjeđan dana prije

a gathering and a knowledge-transfer event with our close teams: Superior Engineering Ljubljana and FSB Racing Team from Zagreb. The gathering took place in the Great House of Platak, where we spent two evenings. We went through various interesting topics, from suspension to the development of an electric car (for which we received valuable information from teams whose cars have an electric drive), and the topic for conversation and discussion did not disappear in the end. We are extremely grateful to our colleagues for the exchange of knowledge, and we have established the item – with cooperation, communication and interconnectedness, significantly greater goals can be achieved.

Cars & Coffee

As we are not just workaholics who spend time in the garage constructing and tuning, we have shown by participating in events such as Cars & Coffee. Namely, it is an exposition of luxury cars held on a global level, which included our modest but valuable formula RRC5, and we were able to brag about our success so far and gather various observers. For us, it is not luxury that matters, but effort and investment!

After modifications to the last RRC5 car, we had to check the efficiency on testing.

We performed the

testing on several occasions at our well-known location Automotodrom Grobnik. Testing ended with a satisfactory result, with minor issues, and we were able to shift the focus to building a new car, which we guarantee will have even better results. The quizzes at the end of January showed excellent results for the engineering knowledge of our members: we qualified for a competition in Hungary, but the most noteworthy result is the qualification for a competition which is the most prestigious Formula Student competition in Europe! We continued to work with great pride to prepare for the competitions, but a case known to everyone happened – the global pandemic COVID-19. With great sadness, we had to temporarily stop working on the new car due to the inability to come to the faculty, but



## 7.6 riteh waterbike team & adria hydrofoil team



samog natjecanja. Zbog toga, nažalost, ove se godine ne možemo pohvaliti konkretnim rezultatima na natjecanjima, ali se zato možemo zahvaliti našim upornim članovima, koji, bez obzira na navedenu situaciju, nikada nisu odustali od tima i nastavili su s radom i u drugim krajevima Hrvatske! Nadamo se da će nam sljedeća godina donijeti više mogućnosti za rad, uspjehe novoga bolida i novih članova, kako bismo i njima pružili izvanredna iskustva i nova znanja!

also due to the inability of our members from other counties to return. So, our new chassis had to stay bare for a while. But with some work that could have been done through computers, such as construction and simulation, we have enabled continuous operation even in the most difficult times. Due to the pandemic, of course, the competitions were also cancelled. So did FS Alpe Adria 2020, which managed to stand on its feet up to the week before the competition itself, and finally due to the closure of certain borders in Europe. So, unfortunately, this year we cannot boast with specific results from competitions, but we can thank our persistent members who, regardless of the situation, never gave up on the team and continued with possible work in other parts of Croatia! We hope that next year will bring us more opportunities, success for the new car and new members to give them such an extraordinary experience and new knowledge!



Pravi osjećaj za inženjersku struku studenti brodogradnje, ali svakako i studenti strojarstva, elektrotehnike i računarstva, mogu stjecati uključivanjem u rad studentskih projekata Riteh Waterbike Team (RWT) i Adria Hydrofoil Team (AHT). U okviru ovih projekata studenti osmišljavaju, projektiraju i izrađuju sofisticirana plovila. Mentor oba studentska tima je prof. dr. sc. Roko Dejhalla. Sudjelovanjem u radu timova, studenti u praksi primjenjuju teorijska znanja stečena na fakultetu čime ujedno stječu i svoja prva iskustva u inženjerskoj struci budući da prolaze kroz sve faze razvoja plovila: od same ideje, razrade projekta, izrade dijelova pa sve do dovršenja plovila, ispitivanja u moru te konačnog sudjelovanja na natjecanjima. Radom u projektu studenti ujedno stječu znanja i vještine iz organizacije, financija, marketinga, logistike i timskog rada. Rad je isključivo volonterskog karaktera, a sredstva za rad studenti prikupljaju samostalno, traženjem sponzorstava i donacija.

RWT je najstariji studentski tim na Tehničkom fakultetu kroz kojega je prošlo više desetaka studenata, danas uspješnih inženjera i uglednih ljudi iz brodograđevne i strojarske struke. RWT se bavi projektiranjem i izradom vodocikla, inovativnog i ekološki prihvatljivog plovila pokretanog isključivo snagom mišića nogu dviju osoba. Vodocikl moraju projektirati i izraditi studenti, pod vodstvom voditelja tima i stručnog mentora.

Students of naval architecture, but certainly also students of mechanical engineering, electrical engineering and computing, can gain a real feeling for the engineering profession by joining the student projects Riteh Waterbike Team (RWT) and Adria Hydrofoil Team (AHT). Within these projects, students conceptualize, design, and build sophisticated vessels. The mentor of both student teams is Prof. Roko Dejhalla. By participating in teams, students in practice apply the theoretical knowledge acquired at the faculty and in this sense also



acquire their first experience in the engineering profession as they go through all stages of vessel development: from the idea, design, making parts and completion of the vessel, testing at sea and final participation in competitions. By participating in the projects, students also acquire knowledge and skills in organization, finance, marketing, logistics and teamwork. The work is exclusively of a voluntary nature and students raise funds for their work independently, by seeking sponsorships and donations.

RWT is the oldest student team at the Faculty of Engineering, and dozens of students, today successful engineers and distinguished people from the shipbuilding and mechanical engineering professions have passed through the team. RWT is engaged in the design and



7.5 riteh racing team

7.6 riteh waterbike team & adria hydrofoil team



Proces započinje razvojem ideje, nakon čega slijedi njegova izrada sve do samog natjecanja na kraju, a sve uz racionalno korištenje financijskih sredstava te organizaciju cjelokupnog projekta. Ne postoje stroga pravila o izgledu vodocikla, stoga su izvedbe inovativne i ovise o dovitljivosti i znanju, tehničkim mogućnostima i spremnosti tima. Prema pravilima, vodocikli ne smiju biti duži od šest metara, širina im ne smije biti veća od dužine, a gaz ne smije prelaziti 1,5 metara. S plovilom se sudjeluje na međunarodnim regatama (International Waterbike Regatta – IWR) na kojima se natječe u više disciplina i na kojima do izražaja dolaze sve prednosti i nedostaci vodocikla. Natjecanje se sastoji od sedam disciplina: sprint 100 m, slalom 100 m, ubrzanje 10 m, naprijed - stop - natrag 50 m, maraton (1 h), vuča na stupu te utrka iznenađenja. RWT je do sada osmislio, projektirao i izradio ukupno pet vodocikala: Esmeralda (1998.), Zvizda (2009.), Kajzer (2010.), Šijun (2013.) i Tramontana (2017). Zadnji vodocikl Tramontana zamišljen je kao jednotrupno plovilo, a izrađen je tehnikom vakuumske infuzije uz primjenu epoksidne smole i ojačanja od ugljikovih vlakana što je rezultiralo vrlo malom masom plovila. Pored samog vodocikla koji je za sada zgotovljen do skoro 90 %, izrađen je i niz od više brodskih vijaka tehnologijom 3D printanja, uz naknadno presvlačenje površina krila ojačanjem od ugljikovih vlakana. Svaki brodski vijak prilagođen je pojedinoj disciplini u natjecanju.

building of a waterbike, an innovative and environmentally friendly vessel powered solely by the strength of the leg muscles of two persons. The waterbike must be designed and built by students, under the guidance of a team leader and a mentor. The process begins with the development of the idea, followed by its development until the competition at the end, all with the rational use of financial resources and the organization of the entire project. There are no strict rules on the appearance of the waterbike, so the performances are innovative and depend on ingenuity and knowledge, technical capabilities and team readiness. According to the rules, waterbikes must not be longer than six meters, their breadth must not exceed the length, and the draft must not exceed 1.5 meters. With the waterbike the team participates in International Waterbike Regattas (IWR) in which the team competes in several disciplines and in which all the advantages and disadvantages of the waterbike become evident. The competition consists of seven disciplines: sprint 100 m, slalom 100 m, acceleration 10 m, forward - stop - reverse 50 m, marathon (1 h), bollard-pull and surprise race. RWT has so far designed and built a total of five waterbikes: "Esmeralda" (1998), "Zvizda" (2009), "Kaiser" (2010), "Šijun" (2013) and "Tramontana" (2017). The last waterbike "Tramontana" was designed as a monohull vessel, and was made by vacuum

AHT je osnovan u jesen 2015. godine na inicijativu dijela studenata iz RWT kroz suradnju Tehničkog fakulteta i Pomorskog fakulteta u Rijeci. U okviru projekta izrađuje se radijski upravljano hidrokrilno plovilo pogonjeno električnim motorom. S plovilom se sudjeluje na natjecanjima „HYDROcontest“ koja se održavaju pod pokroviteljstvom švicarske fondacije Hydros iz Ženeve koja promovira energetske učinkovite plovila.

Primarni cilj projekta je projektiranje i izrada inovativnih hidrokrilnih plovila u cilju razvoja novih tehnologija prijevoza putnika i dobara. Prema koncepciji natjecanja, stavljen je naglasak na inovativnost u razvoju novih tehnologija u brodogradnji i pomorskoj industriji, poput primjene električne propulzije i hidrokrilne tehnologije, a samim time u središtu je i zaštita okoliša jer je smanjenja emisija stakleničkih plinova. Natjecanje se odvija kroz tri discipline od kojih svaka predstavlja potencijalni način usavršavanja budućeg prijevoza: prijevoz lakog i teškog tereta koji simuliraju prijevoz putnika i robe te jednosatna utrka izdržljivosti čime se provjerava projektna brzina i doplov s obzirom na ograničeni kapacitet baterije. Prema pravilima natjecanja, plovilo mora biti pogonjeno električnom propulzijom i upravljivo daljinskim putem, a dimenzijska ograničenja su 2,5 m x 2,5 m x 2 m. AHT je od svog osnutka do danas uspješno izradio tri plovila koja su sudjelovala na međunarodnim natjecanjima u Lozani i St Tropezu.

Tijekom akademske 2019./2020. godine, aktivnosti oba tima bile su znatno smanjene ili su čak i mirovale, jednim dijelom zbog pandemije koronavirusa, ali također i zbog diplomiranja, a samim tim i odlaska starijih članova timova. U svakom slučaju, timovi još uvijek postoje, a u narednom razdoblju trebat će poraditi na povećanju broja studenata u timovima i obnavljaju aktivnosti.

infusion technique with the use of epoxy resin and carbon fiber reinforcements, which resulted in a very small mass of the waterbike. In addition to the waterbike itself, which has so far been completed to almost 90%, a series of several screw propellers was made using 3D printing technology, with subsequent coating of the blade surfaces with carbon fiber reinforcement. Each screw propeller is adapted to a particular discipline in the regatta.

AHT was founded in the fall of 2015 on the initiative of some students from RWT through the cooperation of the Faculty of Engineering and the Faculty of Maritime Studies in Rijeka. Within the project, a radio-controlled hydrofoil vessel is being built. The vessel is powered by an electric motor, with which the team participates in the "HYDROcontest" competitions held under the auspices of the Swiss foundation "Hydros" from Geneva, which promotes energy efficient vessels.

The primary goal of the project is the designing and building of innovative hydrofoil vessels in order to develop new technologies for the transport of passengers and goods. According to the concept of competition, the emphasis is on innovation in the development of new technologies in the shipbuilding and maritime industry, such as the use of electric propulsion and hydrofoil technology, and

thus the focus is on environmental protection which reduces greenhouse gas emissions. The competition takes place in three disciplines, each of which represents a potential way to improve future maritime transport: light and heavy cargo transport that simulates the transport of passengers and goods and a one-hour endurance race in which the design speed and range with regard to limited battery capacity are verified. According to the competition rules, the vessel must be powered by electric propulsion and controlled remotely, with dimension limits of 2.5 m x 2.5 m x 2 m. Since its foundation, AHT has successfully built three vessels that have participated in international competitions in Lausanne and St Tropez.

During the academic year 2019/2020, the activities of both teams were significantly reduced or even idle, partly due to the coronavirus pandemic, but also because older team members left since graduated. In any case, the teams still exist, and in the forthcoming period efforts on increasing the number of students in the teams and resuming activities will be necessary.



7.6 riteh waterbike team &amp; adria hydrofoil team

7.6 riteh waterbike team &amp; adria hydrofoil team

## 7.7 riteh drone team



RiTeh Drone Team je studentski projekt koji djeluje pod mentorstvom izv. prof. dr. sc. Kristijana Lenca i asistenta Franka Hržića te već četvrtu godinu radi na ostvarenju projekata vezanih za bespilotne letjelice.

RiTeh Drone Team osnovali su u lipnju 2016. godine tri studenta: Domagoj Poljančić, Gordan Nekić i Franko Hržić.

Istraživačka sekcija RiTeh Drone Teama fokusira se na istraživanje i razvoj tehnologija vezanih za procesiranje i prikupljanje podataka pomoću bespilotnih letjelica, za potrebe snimanja i fotografiranja objekata iz zraka te za praćenje trenutnih zakonskih regulativa vezanih za bespilotne letjelice u Hrvatskoj. Trkaća sekcija RiTeh Drone Teama ima svoj primarni fokus na istraživanju, primjeni i unaprjeđenju trkaćih dronova, te na sudjelovanju u utrkama dronova.

Ove su nas godine, na natjecanju LUMEN Development, pod imenom Kvadovi, predstavljali studenti Matija Kelemen, Romano Polić, Mislav Tvrđinić i Marin Vidaković Lipovac. Osvojili su drugo mjesto i, dodatno, nagradu za najbolju prezentaciju rješenja. Implementirali su cjelovit sustav za upravljanje bespilotnim letjelicama s proizvoljno udaljene lokacije. Ujedno smo nastavili suradnju s Hrvatskom agencijom za civilno zrakoplovstvo u educiranju šire javnosti o upotrebi dronova unutar Republike Hrvatske, kao i u edukaciji učenika srednjih škola u korištenju bespilotnih letjelica.

Sudjelovali smo u aktivnostima Studentskog zbora Sveučilišta u Rijeci i bili podrška u istraživanjima na Tehničkom fakultetu.

Svojoj opremi dodali smo nekoliko neophodnih dijelova za bolje i naprednije korištenje već postojećih dronova i simulator leta za pripremu članova za upravljanje trkaćim dronovima.

Trenutno radimo na nekoliko studentskih projekata i regrutiranju novih članova.

U idućoj godini planiramo raditi na osnaživanju povezanosti s gospodarstvom, povećanju trkaće sekcije, izgradnji minipoligona na fakultetu kako bismo osigurali članovima mjesto za vježbanje letenja i pružanju podrške budućim istraživanjima fakulteta.

RiTeh Drone Team is a student project which works under the mentorship of Assoc. Prof. Kristijan Lenac and Assistant Franko Hržić and for the fourth year in a row, have been working on realizing projects related to uncrewed aerial vehicles. Riteh Drone Team was founded by three students at the end of June 2016: Domagoj Poljančić, Gordan Nekić, and Franko Hržić.

Riteh Drone Team research section focuses on research and development of technologies related to processing and collecting data using uncrewed aerial vehicles, various recordings, and following current legal regulations related to uncrewed aerial vehicles in Croatia. RiTeh Drone Team racing section has its primary focus on researching, applying, and improving racing drones and participating in drone races.

This year, at the LUMEN Development competition, under the name Kvadovi, we were represented by students Matija Kelemen, Romano Polić, Mislav Tvrđinić, and Marin Vidaković Lipovac, where they won the second place and an additional award for the best presentation of the solution. They implemented a complete drone control system from an arbitrarily remote location. At the same time, we continued our cooperation with the Croatian Civil Aviation Agency in educating the general public about the use of drones within the Republic of Croatia, as well as in educating high school students in the use of uncrewed aerial vehicles.

We participated in the Student Council activities of the University of Rijeka and were support in research at the Faculty of Engineering.

We have added to our equipment several necessary parts for better and more advanced use of the already existing drones and a flight simulator to prepare members to operate racing drones.

We are currently working on several student projects and recruiting new members.

Next year, we plan to strengthen connections with the economy, increase the race section, build mini-polygons in college to provide members with a place to practice flying and provide support for further college research.



## 7.8 riteh web team

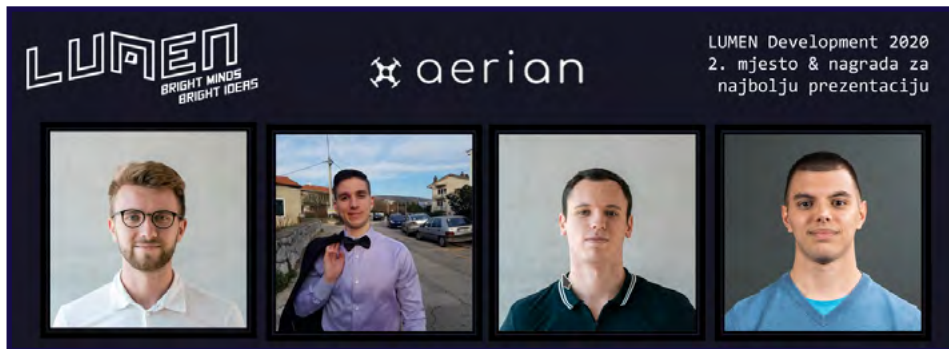

Riteh Web Team je osnovan krajem 2014. godine pod vodstvom doc. dr. sc. Damira Arbule i doc. dr. sc. Sandija Ljubića. Osnovni ciljevi rada tima su razmjena iskustava i znanja među studentima i mentorski rad koji se provodi kroz sastanke, radionice i revizije programskih kodova, a ponajprije stjecanje iskustva u izradi web i mobilnih aplikacija: od ideje, prikupljanja specifikacija, osmišljavanja arhitekture i razvoja do produkcijske razine i puštanja u rad.

Korisnici aplikacija su većinom zaposlenici Fakulteta, Sveučilišta te sami studenti.

Tim je inicijalno okupljen oko tri projekta: sustava za upravljanje sadržajem weba Tehničkog fakulteta, web aplikacije za automatizirano vrednovanje rješenja zadataka (na predmetima kao što su Programiranje, Algoritmi i strukture podataka i Baze podataka) te sustava Navindo za navigaciju u zatvorenim prostorima.

Web i mobilne aplikacije koje razvijaju članovi tima teže korištenju najmodernijih tehnologija i razvojnih metoda.

Kroz rad tima nastale su brojne zanimljive web aplikacije od kojih se, osim već spomenutih, može izdvojiti Ticketing sustav kojega aktivno koriste zaposlenici Tehničkog fakulteta, primarno za potrebe rada Tehničke službe i Računalnog centra. Ticketing sustav omogućuje zaposlenicima Fakulteta prijavu određenog problema nakon čega ga preuzimaju relevantne službe zadužene za rješavanje, a čiji agenti putem sustava mogu komunicirati i obavijestiti sve zainteresirane strane o trenutnom stanju problema i postupku rješavanja.

Mnogi studenti uključuju se u rad tima kroz projekte te završne i diplomske radove u kojima imaju prilike raditi na stvarnim problemima, u najnovijim tehnologijama, uz mentoriranje profesora i starijih studenata koji su u timu već više godina. Studenti tako stječu vrijedno radno iskustvo koje mogu istaknuti u svojim životopisima.

Riteh Web Team was founded in late 2014 under the leadership of Assist. Prof. D. Sc. Damir Arbula and Assist. Prof. D. Sc. Sandi Ljubić. The main goals of the team's work are exchanging experience and knowledge among students and mentored work through meetings and workshops, code reviews and, most importantly, gaining experience in web and mobile application development: from the idea, assembling specifications, designing the architecture to the production level and finally creating a release.

The users of the team's apps are mainly the Faculty and University employees and the students themselves.

The team initially focused on three projects: (1) web content management system for the Faculty of Engineering website, (2) web application for automated evaluation of task solutions (for classes such as Programming, Algorithms and Data Structures, and Database Systems), and (3) Navindo system for indoor navigation.

Web and mobile applications developed by team members strive to use the latest technologies and development methods.

As a result of the team's work, many interesting web applications have been made. Apart from the aforementioned, we can point out the Ticketing system, which has been actively used by the employees of the Faculty of Engineering, primarily for the needs of Technical/Maintenance Service and Computing Centre. The Ticketing system allows the Faculty employees to enter a specific problem whereupon the office in charge solves the problem. Moreover, the office agents can communicate through the system and can notify all the interested parties about the current state of the problem and the procedure to solve it.

Many students take part in the team's work through projects, bachelors' and masters' theses through which they have an opportunity to work on real problems, using the latest technologies,



Kvaliteta studenata koji su bili članovi tima dokazana je njihovim uspjesima na raznim programerskim natjecanjima i ostvarenim praksama i zaposlenjima u vodećim IT tvrtkama, poput Googlea i Microsofta.

Pojedini članovi tima i ove su akademske godine sudjelovali na Natjecanju timova studenata informatičara hrvatskih sveučilišta te su se, kao pobjednički tim sa Sveučilišta u Rijeci, kvalificirali na Central Europe Regional Contest (CERC 2019) u Pragu.

Osim na natjecanjima u okviru organizacije ACM, neki članovi RWT-a nastoje pokazati svoje znanje i na online natjecanjima kao što su Google Code Jam, Google Hash Code i Codeforces.

Na ovogodišnjem događaju LUMEN Development, najvećem studentskom natjecanju u izradi web i mobilnih aplikacija u Republici Hrvatskoj, članovi Riteh Web Teama, u bliskoj suradnji sa članovima Riteh Drone Teama, osvojili su drugo mjesto i, dodatno, nagradu za najbolju prezentaciju rješenja. Matija Kelemen, Romano Polić, Mislav Tvrđinić i Marin Vidaković Lipovac su implementirali cjeloviti sustav za upravljanje bespilotnim letjelicama s (proizvoljno) udaljene lokacije.

mentored by professors and older students who have been members of the team for many years. In the process they gain valuable work experience which can be pointed out in their resumes.

The quality of student members of the team has been proven through their success in various programming competitions and through the practices and employment within the leading IT companies such as Google and Microsoft.

Some of the team's members participated in the university collegiate programming contest this year and, as the winners from the University of Rijeka, qualified for the Central Europe Regional Contest (CERC 2019) held in Prague.

In addition to competitions within the ACM organization, some RWT members also seek to demonstrate their knowledge in online contests such as Google Code Jam, Google Hash Code and Codeforces.

At this year's LUMEN Development event, the largest student competition in web and mobile application development in the Republic of Croatia, members of the Riteh Web Team, in partnership with members of the Riteh Drone Team, won the second place and, in addition,



Kada se ukaže odgovarajuća prilika, članovi tima usavršavaju svoja znanja i vještine prisustvovanjem na relevantnim stručnim skupovima.

the award for best presentation of the solution. Matija Kelemen, Romano Polić, Mislav Tvrđinić and Marin Vidaković Lipovac implemented a full-stack drone control system, allowing users to control a drone from an (arbitrarily) remote location.

When the opportunity arises, the team members improve their knowledge and skills by attending relevant professional conferences.

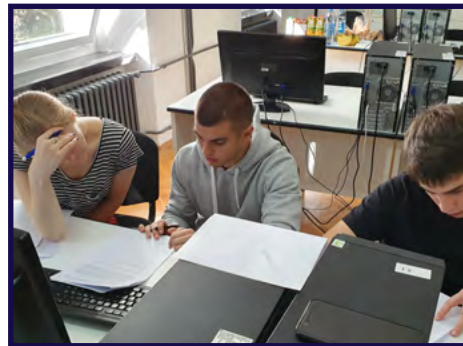

7.8 riteh web team

## 7.9 projekt here the "here" project



Projekt "Here" započeo je s idejom Damira Urbana u doprinosu pozitivnog konteksta životu osobama koje se mogu naći u zahtjevnim životnim situacijama koje iziskuju malu pomoć. U tome smislu, prije godinu i pol dana, održan je neformalni susret Damira Urbana kao začetnika ideje, naše rektorice, Snježane Prijić-Samaržije, tadašnje dekanice Tehničkog fakulteta prof. dr. sc. Jasne Prpić-Oršić i prof. dr. sc. Marine Franulović, sadašnje prodekanice za znanstvenu djelatnost Tehničkog fakulteta. Marina Franulović prezentirala je ideju grupi studenata diplomskog sveučilišnog studija strojarstva, upisnih na smjer Konstruiranje i mehatronika, a koju čine izvrsni studenti: Adriano Kovaček, Tomislav Ploh, Senada Abdić, Franko Antić i Marcel Gačar. Studenti su, okupljeni u tim pod njenim vodstvom, s puno entuzijazma prihvatili izazov izrade konstrukcijskog rješenja koje može sa sigurnošću ispuniti sve postavljene zahtjeve kojih, samo naizgled, nije bilo puno. Izradili su nekoliko konceptata rješenja, u raspravama izabrali najbolje, dimenzionirali konstrukciju, proveli analitičke i numeričke proračune i kontrolu čvrstoće, modelirali konstrukciju i simulirali njeno ponašanje u uvjetima primjene. Pri tome su iskoristili priliku iskoristiti široko znanje koje na fakultetu ostvaruju na interesantan i izazovan način. S vremenom se, u

The "Here" project started with Damir Urban's idea to contribute to the positive context of life of people who can find themselves in various life situations when they need a little help. In that sense, a year and a half ago, an informal meeting was held between Damir Urban as the founder of the idea, our rector, Snježana Prijić - Samaržija, the former dean of the Faculty of Engineering Prof. D. Sc. Jasna Prpić-Oršić and Prof. D. Sc. Marina Franulović, the current vice dean for scientific activities of the Faculty of Engineering. Marina Franulović presented the idea to a group of students of the graduate university study of mechanical engineering who enrolled in the field of Design and Mechatronics, which consists of excellent students: Adriano Kovaček, Tomislav Ploh, Senada Abdić, Franko Antić and Marcel Gačar. The students, as a team under her mentoring, accepted with great enthusiasm the challenge of creating a construction solution that can meet all the set requirements, which only seemingly were not many. They developed several solution concepts, selected the best through the discussions, dimensioned the structure, performed analytical and numerical calculations and strength control, modeled the structure and simulated its behavior under application conditions. In doing so, they used

7.9 projekt here the "here" project

susretima s idejnim začetnikom Damirom Urbanom, instalacija razvijala i doradivala te u ovom trenutku postoji njeno rješenje s kojim će se ići u realizaciju. Dekan Tehničkog fakulteta, prof. dr. sc. Duško Pavlečić, podržao je ideju te se također uključio u aktivnosti Tehničkog fakulteta kako bi osigurao realizaciju projekta. Na fakultetu se formira još jedan tim studenata i to onih iz polja računarstva koji će pod vodstvom docenta dr. sc. Sandija Ljubića izraditi mobilnu i web aplikaciju za upravljanje afirmativnim porukama koje će se kroz instalaciju iskazivati.

Trenutno je idejno rješenje temelj na kojem će Sveučilište u Rijeci, pod vodstvom rektorice Snježane Prijčić-Samaržije i uz Damira Urbana osigurati upravljanje aktivnostima za njegovo postavljanje, proizvodnju, postavljanje infrastrukture, sigurnosti pri korištenju, diseminacije i svih popratnih radnji. U tome smislu očekuje se uključivanje studenata Filozofskog fakulteta te Akademije primijenjenih umjetnosti Sveučilišta u Rijeci. Posebno će interesantno biti vidjeti sinergiju između studenata različitih interesa u ostvarenju zajedničkog cilja.

the opportunity to use the broad knowledge that they gain at the Faculty in an interesting and challenging way. Over time, in meetings with the founder of the idea, Damir Urban, the installation was developed and refined, and at the moment there is a solution that will be implemented. The Dean of the Faculty, prof. D. Sc. Duško Pavlečić supported the idea and also got involved in the activities of the Faculty to ensure the realization of the project. Another team of students is being formed at the Faculty, namely those from the field of computer science who will, under the mentoring of Assist. Prof. D. Sc. Sandi Ljubić create a mobile and web application for managing affirmative messages that will be expressed through the installation.

Currently, the conceptual design is the basis on which the University of Rijeka, led by Rector Snježana Prijčić - Samaržija and Damir Urban, will ensure the management of activities for its installation, production, infrastructure installation, safety in use, dissemination and all accompanying activities. In this sense, it is expected that students of the Faculty of Humanities and Social Sciences and the Academy of Applied Arts of the University of Rijeka will be involved in the development of the project. It will be especially interesting to see the synergy between students of different interests in achieving a common goal.

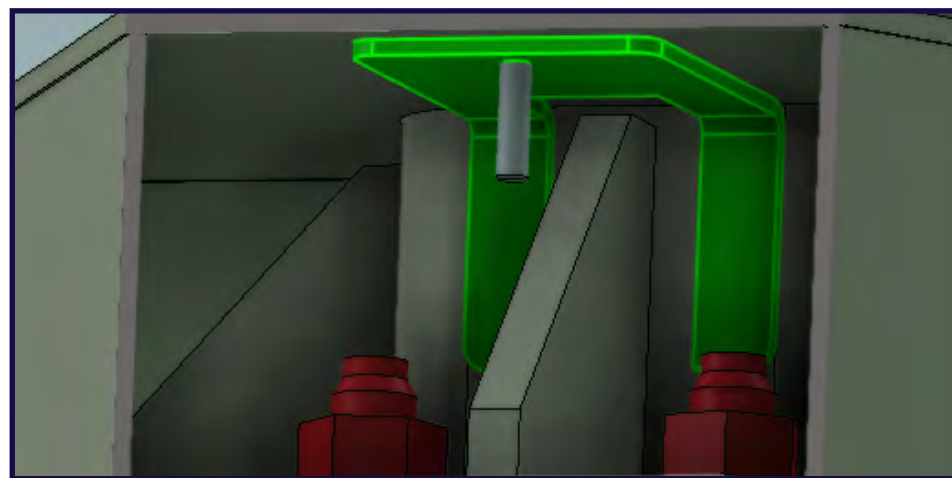
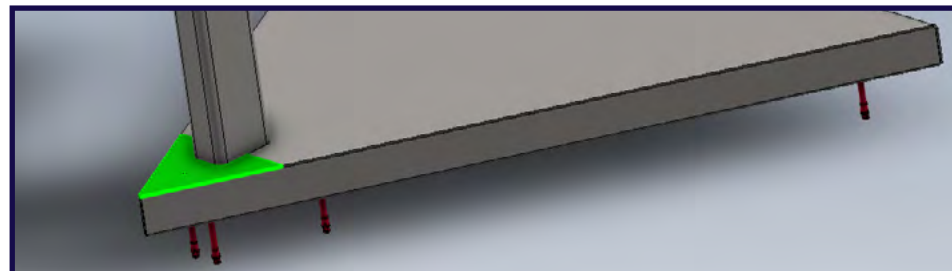

7.9 projekt here the "here" project

## 7.10 21. mornarska regata 21<sup>st</sup> rowing regatta



Tehnički fakultet je sa svojim ekipama uspješno nastupio na 21. međunarodnoj regati u mornarskom veslanju u slovenskom Portorožu (21. mednarodno veslaško tekmovanje v kuterjih). Na ovoj regati su nastupile muška i ženska veslačka ekipa s oznakama RiTeh. Regata je održana u subotu 9. studenog 2019. godine, unatoč mogućnosti otkazivanja zbog nepovoljnih vremenskih prilika. Ipak, pred sam početak natjecanja, vrijeme se poboljšalo i dvadesetak ekipa je odmjerilo svoje snage.

Premda je ženska ekipa bila poražena od domaćih višestrukih prvakinja, uspjeh nije umanjen jer je postignuto vrijeme u rangu muških ekipa. Više je sreće sa ždrijebom imala muška ekipa koja je prošla prvi eliminacijski ciklus i našla se među osam najboljih ekipa.

U borbi za polufinale, kolege s Pomorskog fakulteta u Trstu bili su brži za nekoliko sekundi.

Ipak, natjecanje je proteklo u vedrom raspoloženju i pod povoljnim vremenskim uvjetima.

Kao i ranijih godina, na natjecanju su bili najuspješniji slovenski natjecatelji. Sudjelovalo je dvadesetak ekipa sa sveučilišta iz Slovenije, Hrvatske, Italije i Srbije.

Rowing teams of Faculty of Engineering, University of Rijeka 21. attend rowing regatta organized by the Faculty of Maritime Studies and Transport (Ljubljana University).

9th of November 2019 rowing regatta took place in port of Piran. Regatta was hard to organize because of heavy raining days before the planned meeting. Fortunately, weather improved minutes before the competition.

Female rowing team was defeated by favored slovene team, however the Riteh male team win the first race and continue the competition. Finally, Riteh male team took 6th place. Slovene teams win both male and female competition.

More than 20 teams from Croatia, Slovenia, Italy and Serbia attend the regatta which ended with medal ceremony. Competition took place in good mood with social events organized by host and sponsored by different companies.

7.10 21. mornarska regata 21st rowing regatta



## 7.11 akademski sport - uspjesi sportaša academic sport - achievements of athletes



I u ovoj, po svemu zahtjevnoj godini, naši studenti su se natjecali u sklopu Unisport lige. Nažalost, zbog epidemije koronavirusa, sezona je prekinuta odmah na početku ljetnog semestra. Zbog toga se brojni sportovi nisu ni održali pa nismo mogli pokazati našu sportsku kvalitetu. Ipak, određena su se natjecanja uspjela održati u zimskom semestru gdje smo ponovno pokazali kako smo na našem Sveučilištu još uvijek izuzetno konkurentni.

### Rezultati po sportovima Unisport lige:

- Futsal** – 1. mjesto (M), 3. mjesto (M), 1. mjesto (Ž)
- Košarka** – 3. mjesto (M)
- Rukomet** – 1. mjesto (M)
- Odbojka** – 3. mjesto (M), 2. mjesto (Ž)
- Squash** – 1. mjesto (M)
- Cageball** – 2. mjesto (M)
- Badminton** – 1. mjesto (M), 3. mjesto (M), 3. mjesto (Ž)
- Šah** – 2. mjesto (M)

U također okrnjenom izdanju se održalo državno sveučilišno prvenstvo u šahu i odbojci na pijesku. Studenti Tehničkog fakulteta predstavljali su naše Sveučilište u natjecanju u šahu i osvojili prvo mjesto.

Our students competed in the Unisport League even in this very demanding year. Unfortunately, due to the coronavirus epidemic, the season was interrupted right at the beginning of the summer semester. Due to that, many sport events did not even take place, so we could not show our sports quality. Nevertheless, certain competitions managed to take place in the winter semester where we once again showed to be still extremely competitive at our University.

### Results in each sport of the Unisport League:

- Futsal** – 1<sup>st</sup> place (M), 3<sup>rd</sup> place (M), 1<sup>st</sup> place (F)
- Basketball** – 3<sup>rd</sup> place (M)
- Handball** – 1<sup>st</sup> place (M)
- Volleyball** – 3<sup>rd</sup> place (M), 2<sup>nd</sup> place (F)
- Squash** – 1<sup>st</sup> place (M)
- Cageball** – 2<sup>nd</sup> place (M)
- Badminton** – 1<sup>st</sup> place (M-individually), 3<sup>rd</sup> place (M-individually), 3<sup>rd</sup> place (F)
- Chess** – 2<sup>nd</sup> place (M)

The state university chess and beach volleyball championship was also held in a reduced edition. Students of the Faculty of Engineering participated in a chess competition and won an excellent first place.



7.11 riteh akademski sport - uspjesi sportaša academic sport - achievements of athletes

7.11 riteh akademski sport - uspjesi sportaša academic sport - achievements of athletes



7.11 riteh akademski sport - uspjesi sportaša academic sport - achievements of athletes

7.11 riteh akademski sport - uspjesi sportaša academic sport - achievements of athletes





Sveučilište u Rijeci  
TEHNIČKI FAKULTET  
[www.riteh.uniri.hr](http://www.riteh.uniri.hr)



University of Rijeka  
FACULTY OF ENGINEERING  
[www.riteh.uniri.hr](http://www.riteh.uniri.hr)